

Drives

WV401 - WV630



- Vibration compensation with rubber buffer
- Heavier bowls can be used due to coarser vibration behavior
- Full wave and half wave operation possible depending on the application

Overview of WV attachment with levelling base

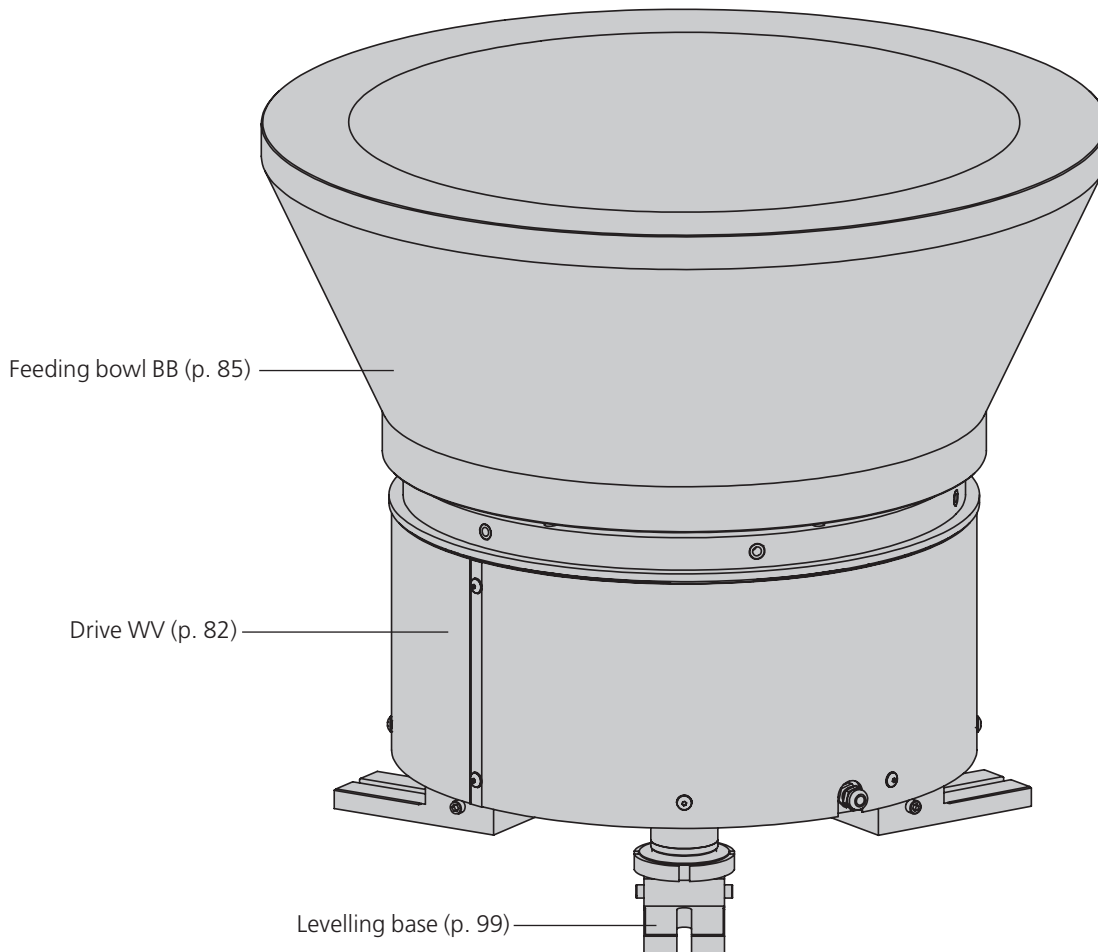

Type	WV401-1	WV402-1	WV630-1
A1	440 mm	440 mm	660 mm
A2	419 mm	419 mm	541 mm
A3	300 mm	300 mm	---
D1	8 x 9 mm	8 x 9 mm	8 x 9 mm
D2	4 x 8H7	4 x 8H7	---
D3	3 x M10	3 x M10	3 x M10
D4	12 x M6	12 x M6	12 x M6
D5	6 x M8	6 x M8	12 x M8x16
E1	400 mm	400 mm	524
E2	360 mm	360 mm	---
E3	350 mm	350 mm	560
E4	320 mm	320 mm	525 mm
H	243 mm	243 mm	248 mm
K	12.5 mm	12.5 mm	12.5 mm
L	5 mm	5 mm	---
M	25 mm	25 mm	25 mm
X1	15 °	15 °	15 °
X2	15 °	15 °	---
X3	30 °	30 °	30 °

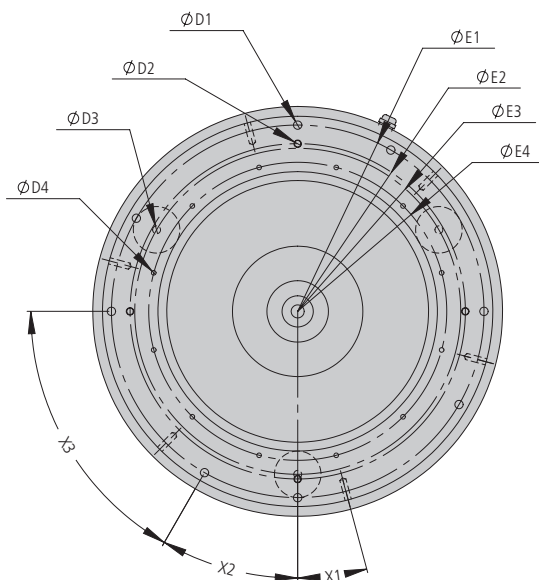
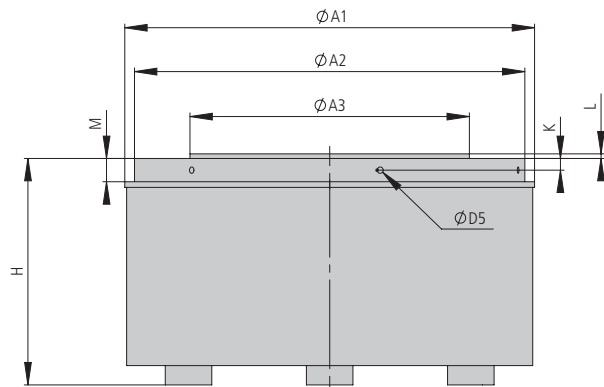

WV401 - WV630				
Operating temperature	10 - 45 °C			
Type	WV401-1	WV401-1	WV401-1	WV401-1
Order number	50177366	50177365	50177373	50177372
Mechanical vibration frequency	50 Hz	50 Hz	60 Hz	60 Hz
Mains connection (mains voltage/mains frequency)	230 V/50 Hz	230 V/50 Hz	115 V/60 Hz	115 V/60 Hz
Max. power consumption	1260 VA	1260 VA	1260 VA	1260 VA
Net weight	100.7 kg	100.5 kg	100.9 kg	100.8 kg
Admissible bowl weight ±30 %	30 kg	30 kg	30 kg	30 kg
Angle of the gradient of the leaf springs	15 °	15 °	15 °	15 °
Delivery direction	right	left	right	left
Protection type	IP54	IP54	IP54	IP54
Type	WV402-1	WV402-1	WV402-1	WV402-1
Order number	50103719	50103718	50177371	50177368
Mechanical vibration frequency	100 Hz	100 Hz	120 Hz	120 Hz
Mains connection (mains voltage/mains frequency)	230 V/50 Hz	230 V/50 Hz	115 V/60 Hz	115 V/60 Hz
Max. power consumption	1128 VA	1128 VA	1128 VA	1128 VA
Net weight	101 kg	101 kg	101.3 kg	101.3 kg
Admissible bowl weight ±30 %	30 kg	30 kg	30 kg	30 kg
Angle of the gradient of the leaf springs	15 °	15 °	15 °	15 °
Delivery direction	right	left	right	left
Protection type	IP54	IP54	IP54	IP54
Type			WV630-1	WV630-1
Order number			50455916	50470026
Mechanical vibration frequency			50 Hz	50 Hz
Mains connection (mains voltage/mains frequency)			230 V/50 Hz	230 V/50 Hz
Max. power consumption			1260 VA	1260 VA
Net weight			185 kg	185 kg
Admissible bowl weight ±30 %			50 kg	50 kg
Angle of the gradient of the leaf springs			15 °	15 °
Delivery direction			right	left
Protection type			IP54	IP54

Included in delivery

- 4x Leaf spring WV
- 8x Spacers WV