

# Rotary modules compact CR

CR 12 - CR 32

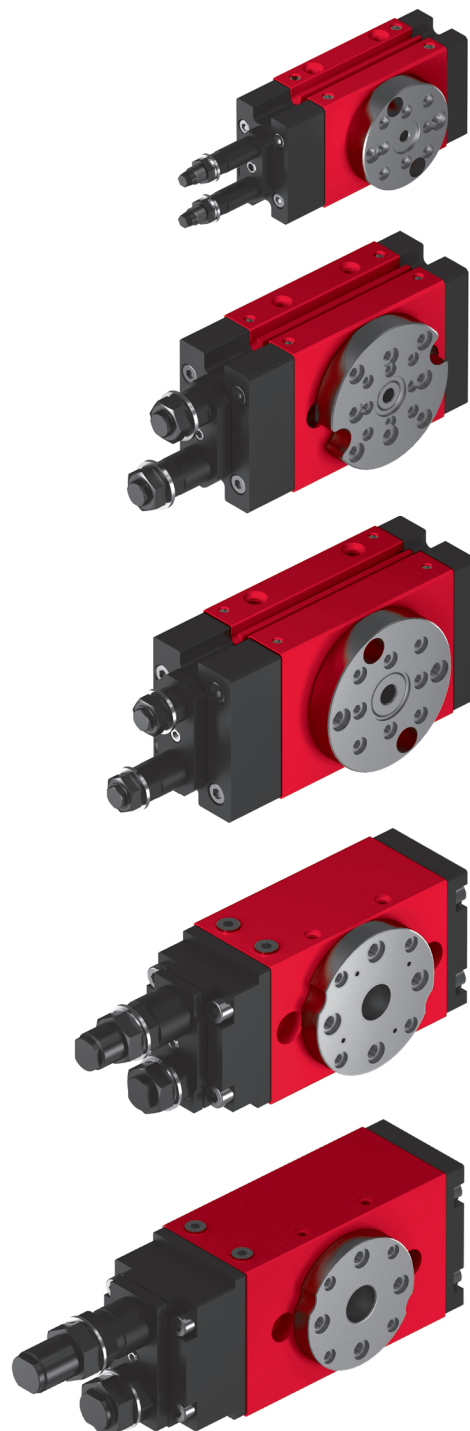

# Table of contents: CR

<b>Rotary modules compact CR</b>	<b>Page</b>
CR 12	11
CR 16	17
CR 20	27
CR 25	37
CR 32	43
Accessories CR	49

Legend	
A	stop screw 1
B	stop screw 2
C	clamping screw
P1	air connection, clockwise
P2	air connection, counterclockwise

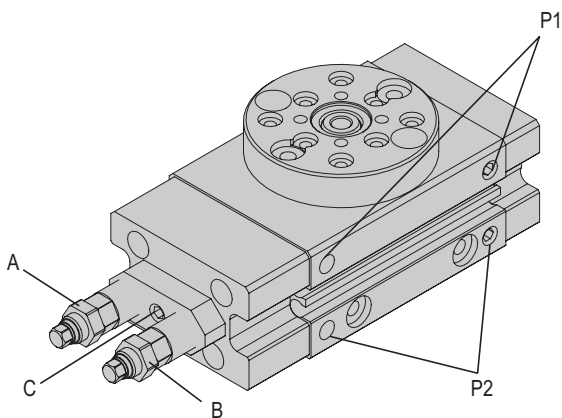

### Adjustment of end position:

- Compressed air at (P1): shaft rotates clockwise
- Release clamp of stop screw: unscrew clamping screw C
- Set position by turning stop screw 1
- Compressed air at (P2): shaft rotates counterclockwise
- Set position by turning stop screw 2
- Fix stop screws by clamp: tighten clamping screw C

### Angle of rotation:

Maximum angle of rotation = 180°

The flange holes drawn are at 0° for all the modules  
Thus the flange is rotating 90° left and 90° to right.

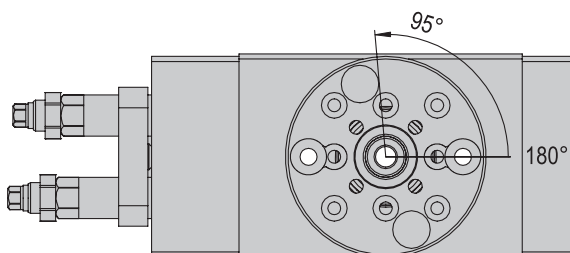
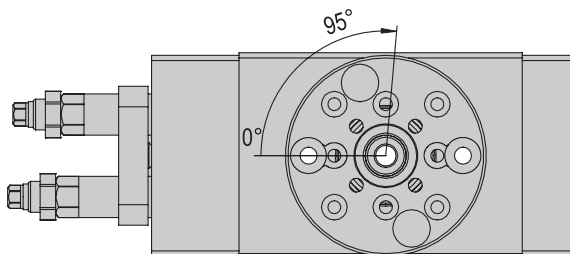
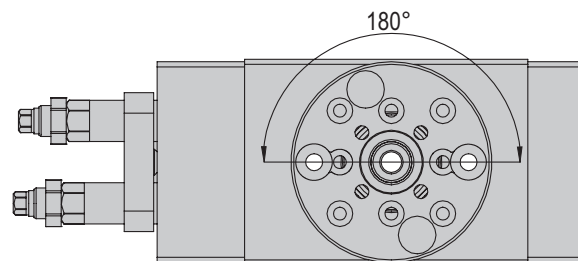

### Reduction of angle of rotation:

Starting from a position between 0° and 180° the end positions can be reduced by maximum of 95°.

- Fixation by screwing in the corresponding stop screw.

Legend	
A	retracting
B	clamping screw
C	positions pin 1
D	positions pin 2
E	extending

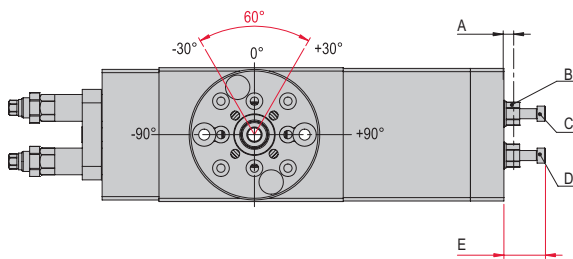

**Intermediate positions:**

The intermediate stop module ZA can move to up to 2 intermediate positions.

**Adjusting range of der intermediate position/s:**

The max. intermediate position 60°, (30° for left, and 30° for right) relating to 0° position.

**Adjustment of intermediate positions:**

- Loosen the two lock nuts B and unscrew both positioning pins C and D completely (up to the mechanical stop).
- Retighten lock nuts B slightly in order to check tightness when the system is ventilated.
- Push in positioning pins C and D by hand and vent with operating pressure at P3.
- Vent P1. Shaft rotates clockwise.
- Set the desired intermediate position with positioning pin 1.
- Fasten positioning pin 1 with lock nut.
- Vent P2. Shaft rotates counterclockwise.
- Screw in positioning pin 2 up to resistance.
- Secure positioning pin 2. Both positioning pins are now contacting the rotary module piston.

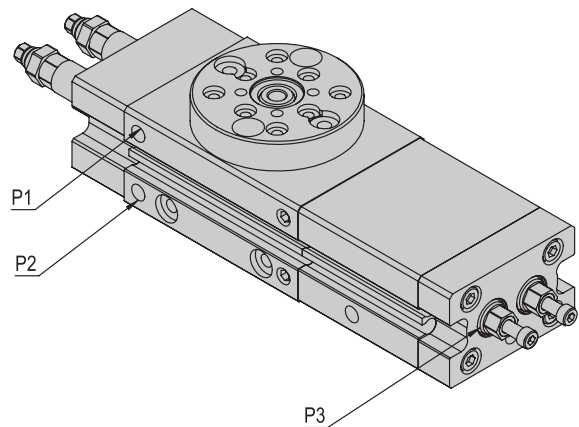

For more information visit: [www.afag.com](http://www.afag.com)  
 Operating manual CR 12/CR 16/CR 20/CR 25/CR 32



# Rotary modules compact CR

## CR 12

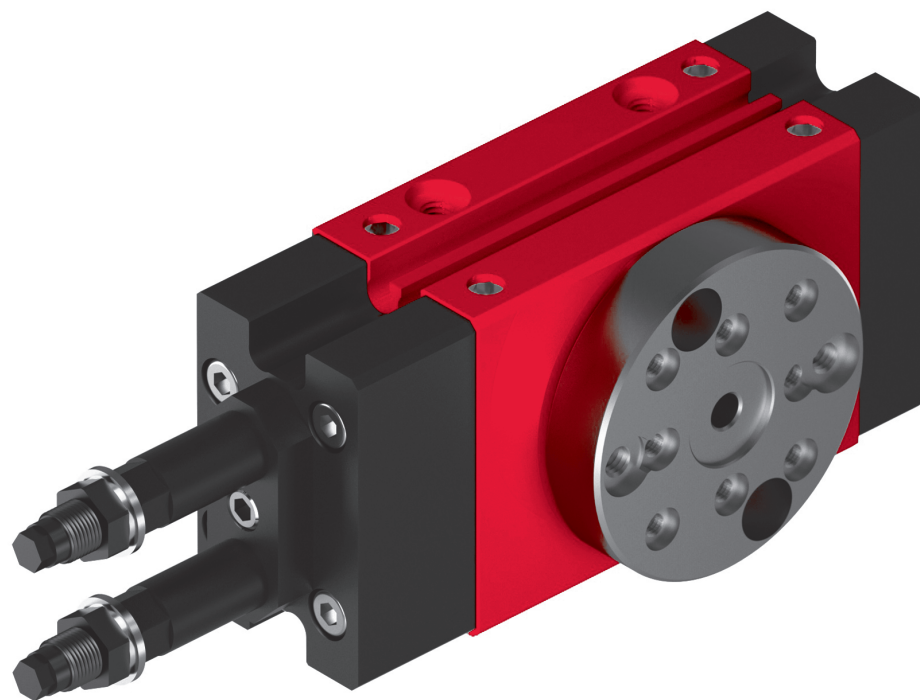

- Compact design
- Optionally with intermediate position
- High mass inertias

# Dimensions and dimension drawings

CR 12

Type	CR 12	CR 12 - ZA
A	Bore fitting	Bore fitting
P	M5	M5
P1	Clockwise	Clockwise
P2	Counterclockwise	Counterclockwise

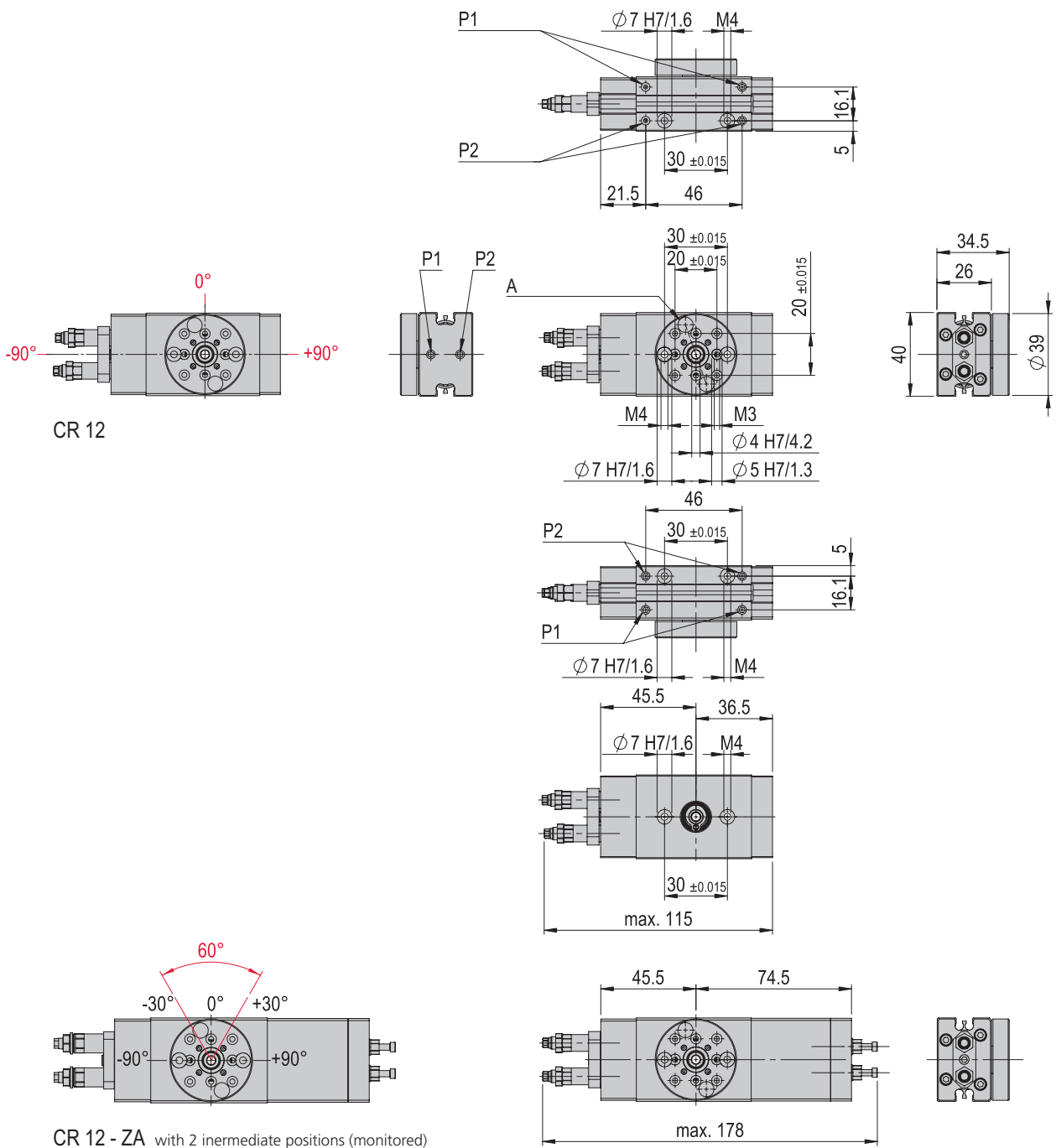

The flange hole patterns shown are in the 0° position for all modules. The flange rotates 95° to the left and 95° to the right.

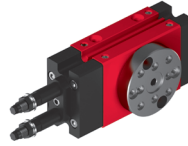

CR 12	
Attachment grid	48 mm
Attachment grid alternative	30 mm
Attachment thread	M6
Attachment thread alternative	M4
Operating pressure	6 +/- 2 bar
Air connection P	M5
Operating temperature	0 - 50 °C
Storage temperature	0 - 50 °C
Humidity	< 90 %
Medium filtered compressed air	10 - 40 µm

Type	CR 12	CR 12 - ZA
<b>Order number</b>	<b>50112939</b>	<b>50112940</b>
Net weight	0.324 kg	0.42 kg
Air consumption (180°)	0.0009 NL	0.0009 NL
Angle of rotation	0-180 °	0-180 °
Min. rotation time 180°	0.15 s	0.15 s
Noise level	54 dB (A)	54 dB (A)
Angle accuracy	+/- 0.06 °	+/- 0.06 °
Torque	0.45 Nm	0.45 Nm
Max. moment of inertia	*10 kgcm <sup>2</sup>	*10 kgcm <sup>2</sup>
Positions	2	4
Mounting position	⚡	⚡

The technical data refer to a nominal pressure of 6 bar under Afag standard test conditions.

Note: If a turning force acts against the direction of rotation in the end position, a drive with twice the theoretical torque should be selected.

The module can be operated with lubricated or dry air. It is possible to switch from dry to lubricated but not vice versa.

Cleanroom class ISO 14644-1, class ISO 7

\*Observe rotation time diagram

### Included in the delivery

(Catalogue HT accessories)

- 2x Centering bushing Ø7x3
- 2x Special screw M4 x 30/8.5
- 2x Shock absorber SD M6x0.5 -2

### Accessories

(Catalogue HT accessories)

- INI c10x28.5-Em-PNP-NO-M8x1

Warranty: 24 months following commissioning, but a maximum of 27 months following delivery

afag.com



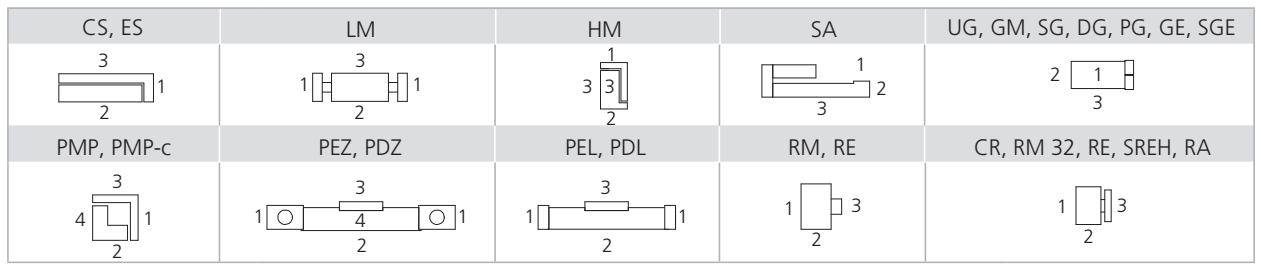
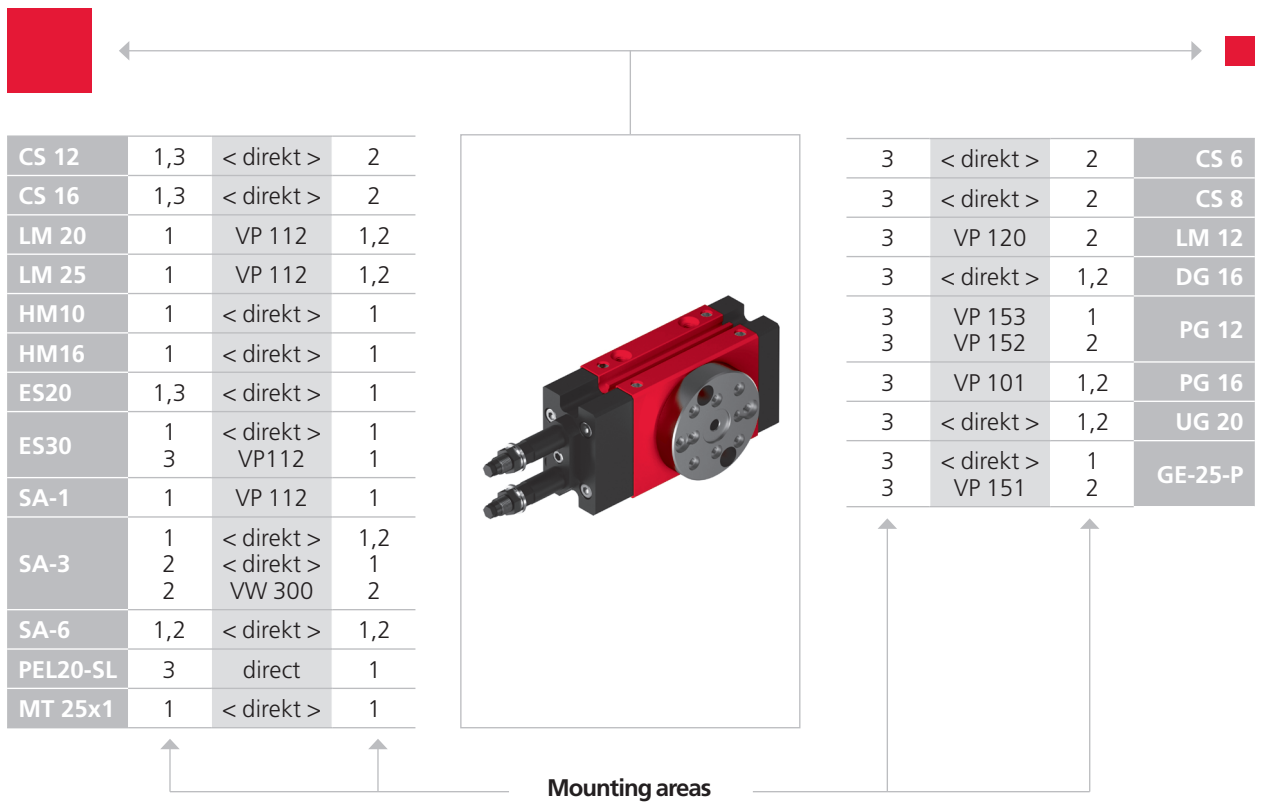

Note that there might be different mounting positions from one module to another one.  
The required connection elements and the range of support columns are depicted in the catalogue HT accessories.

Type	CR 12	CR 12 - ZA
Max. force, axial pushing static	200 N	200 N
Max. force, axial pulling static	100 N	100 N
Max. force, axial pushing dynamic	80 N	80 N
Max. force, axial pulling dynamic	40 N	40 N
Max. payload, radial dynamic	130 N	130 N
Max. payload, radial static	340 N	340 N

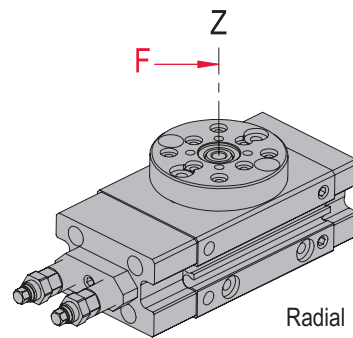
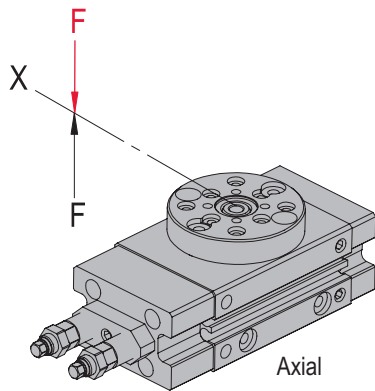

## Load diagrams

Axial dynamic

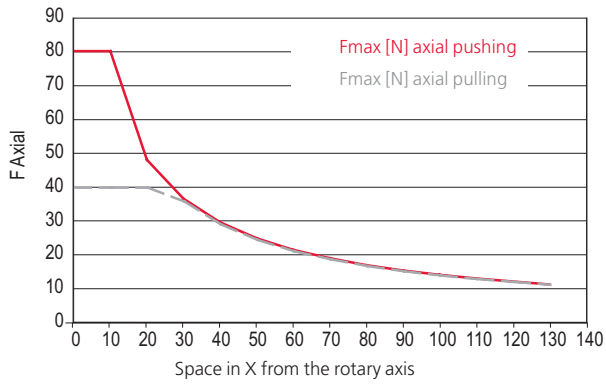

Axial static

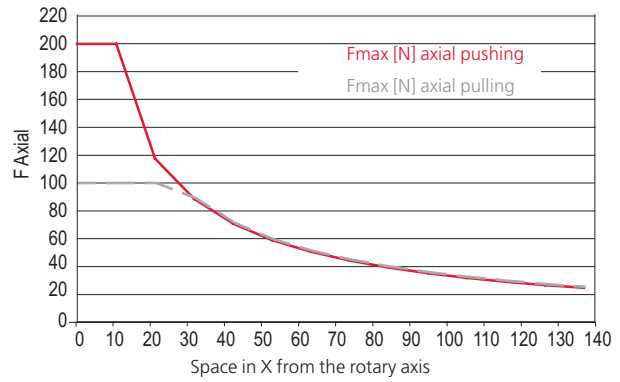

Radial dynamic

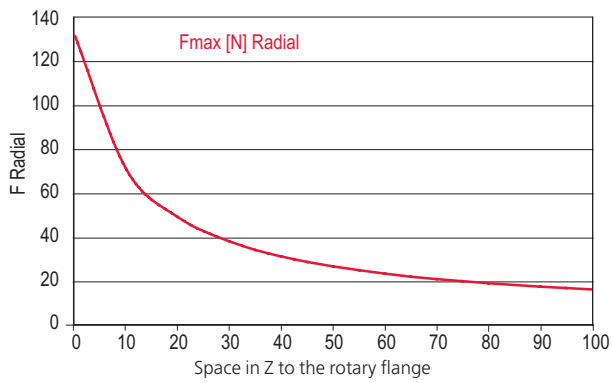

Radial static

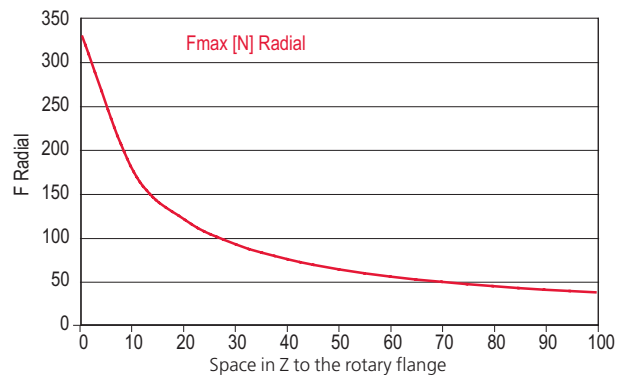

Rotation time

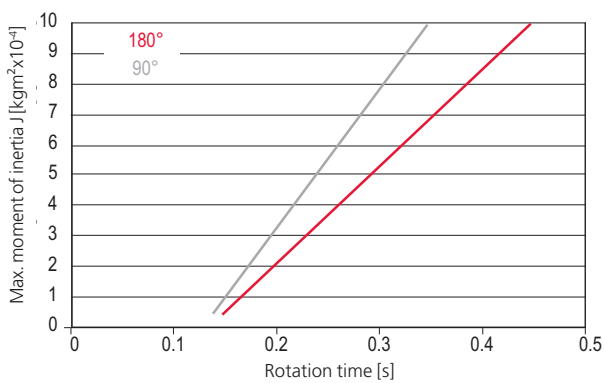

# Rotary modules compact CR

## CR 16

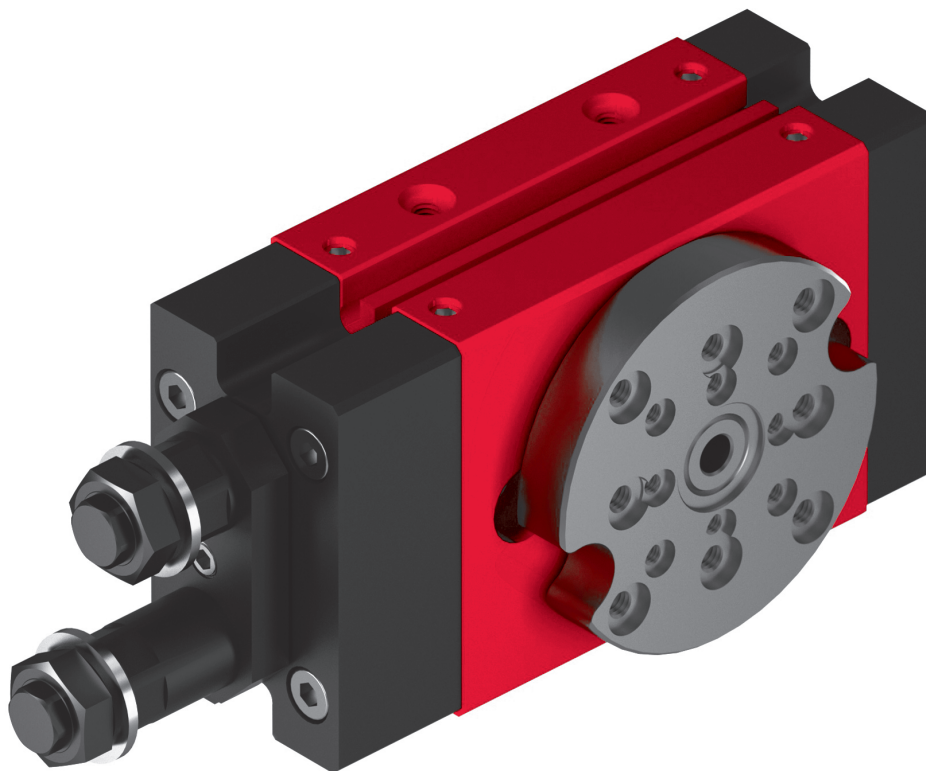

- Compact design
- Optionally with intermediate position
- High mass inertias



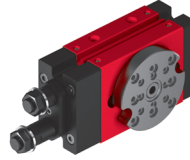

CR 16	
Attachment grid	48 mm
Attachment grid alternative	30 mm
Attachment thread	M6
Attachment thread alternative	M4
Operating pressure	6 +/- 2 bar
Air connection P	M5
Operating temperature	0 - 50 °C
Storage temperature	0 - 50 °C
Humidity	< 90 %
Medium filtered compressed air	10 - 40 µm

Type	CR 16	CR 16 - ZA
<b>Order number</b>	<b>50112941</b>	<b>50112942</b>
Net weight	0.69 kg	0.9 kg
Air consumption (180°)	0.0018 NL	0.0018 NL
Angle of rotation	0-180 °	0-180 °
Min. rotation time 180°	0.27 s	0.27 s
Noise level	54 dB (A)	54 dB (A)
Angle accuracy	+/- 0.05 °	+/- 0.05 °
Torque	1.25 Nm	1.25 Nm
Max. moment of inertia	*70 kgcm <sup>2</sup>	*70 kgcm <sup>2</sup>
Positions	2	4
Mounting position		

The technical data refer to a nominal pressure of 6 bar under Afag standard test conditions.

Note: If a turning force acts against the direction of rotation in the end position, a drive with twice the theoretical torque should be selected. The module can be operated with lubricated or dry air. It is possible to switch from dry to lubricated but not vice versa. Cleanroom class ISO 14644-1, class ISO 7

\* Observe swivel time diagram

### Included in the delivery

(Catalogue HT accessories)

- 2x Centering bushing Ø7x3
- 2x Centering bushing Ø9x4
- 2x Special screw M6 x 36/8
- 2x Shock absorber SD M10x1 -4

### Accessories

(Catalogue HT accessories)

- INI c10x28.5-Em-PNP-NO-M8x1

Warranty: 24 months following commissioning, but a maximum of 27 months following delivery

# Dimensions and dimension drawings

CR 16-D

Type	CR 16-D	CR 16-ZA-D
A	Bore fitting	Bore fitting
P	M5	M5
P1	Clockwise	Clockwise
P2	Anti-clockwise	Anti-clockwise

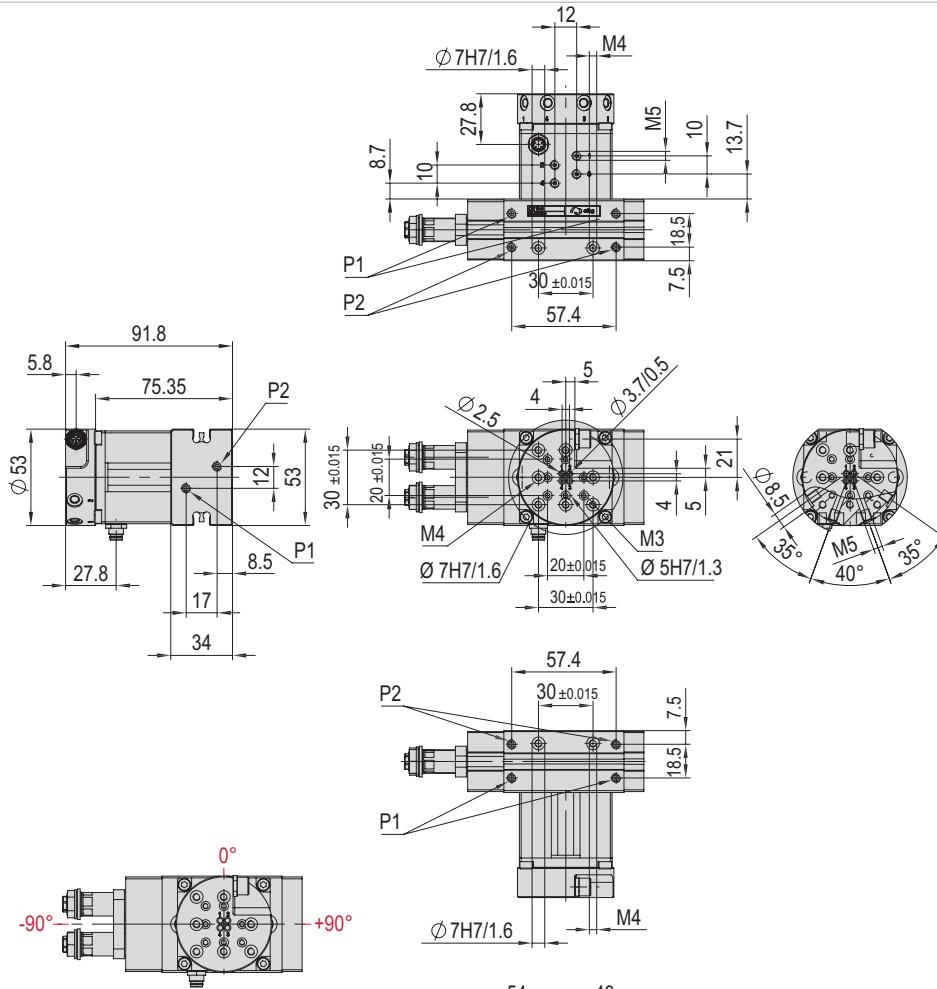

CR 16-D

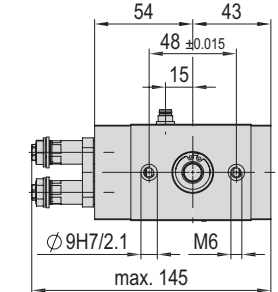

CR 16-ZA-D

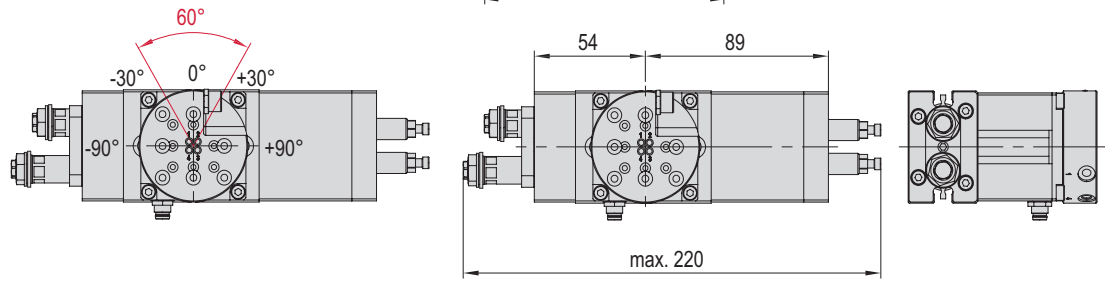

The flange hole patterns shown are in the 0° position for all modules. The flange rotates 95° to the left and 95° to the right.

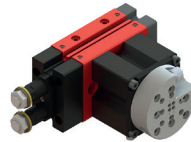

CR 16	
Attachment grid	48 mm
Attachment grid alternative	30 mm
Attachment thread	M6
Attachment thread alternative	M4
Operating pressure	6 +/- 2 bar
Air connection P	M5
Operating temperature	0 - 50 °C
Storage temperature	0 - 50 °C
Humidity	< 90 %
Medium filtered compressed air	10 - 40 µm

Type	CR 16-D	CR 16-ZA-D
<b>Order number</b>	<b>50433054</b>	<b>50433057</b>
Net weight	1.02 kg	1.23 kg
Air consumption (180°)	0.0018 NL	0.0018 NL
Angle of rotation	0-180 °	0-180 °
Electrical feed-through	6 x 1 A	6 x 1 A
Rotary supply fluids	4 x M5	4 x M5
Min. rotation time 180°	0.27 s	0.27 s
Noise level	54 dB (A)	54 dB (A)
Angle accuracy	+/- 0.05 °	+/- 0.05 °
Torque	0.95 Nm	0.95 Nm
Max. moment of inertia	*70 kgcm <sup>2</sup>	*70 kgcm <sup>2</sup>
Positions	2	4
Mounting position		

The technical data refer to a nominal pressure of 6 bar under Afag standard test conditions.

Note: If a turning force acts against the direction of rotation in the end position, a drive with twice the theoretical torque should be selected. The module can be operated with lubricated or dry air. It is possible to switch from dry to lubricated but not vice versa. Cleanroom class ISO 14644-1, class ISO 7

\* Observe swivel time diagram

### Included in the delivery

(Catalogue HT accessories)

- 2x Centering bushing Ø7x3
- 2x Centering bushing Ø9x4
- 2x Special screw M6 x 36/8
- 2x Shock absorber SD M10x1 -4
- 4x O-ring 2.5x0.62 mm
- 2x Set screw M5x4

### Accessories

(Catalogue HT accessories)

- INI c10x28.5-Em-PNP-NO-M8x1
- Sensor act. cable-6pol-female-5m-0-open-1
- Sensor act. cable-6pol-male-0.6m-0-open-1

Warranty: 24 months following commissioning, but a maximum of 27 months following delivery



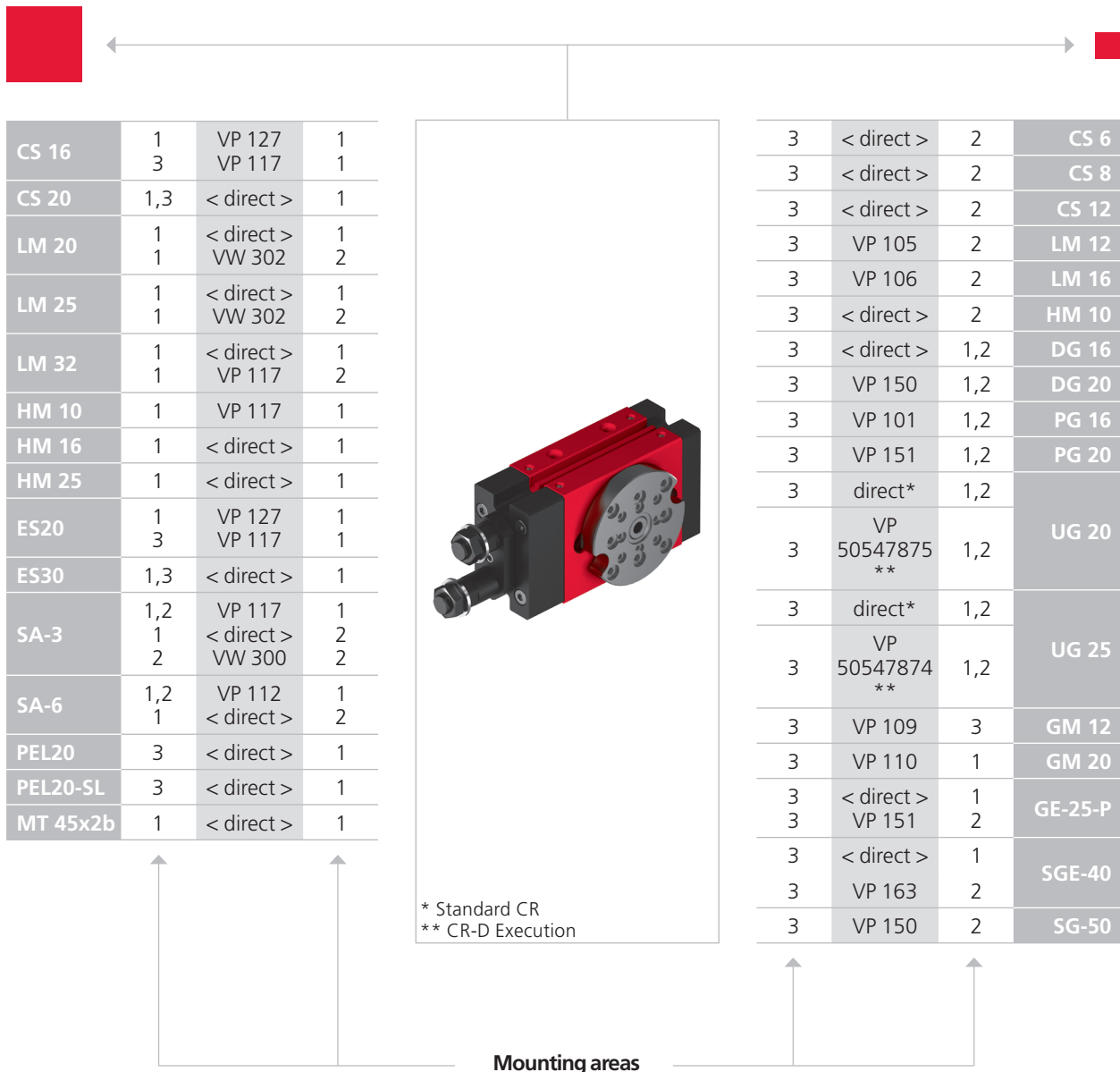

CS, ES	LM	HM	SA	UG, GM, SG, DG, PG, GE, SGE
PMP, PMP-c	PEZ, PDZ	PEL, PDL	RM, RE	CR, RM 32, RE, SREH, RA

Note that there might be different mounting positions from one module to another one.  
The required connection elements and the range of support columns are depicted in the catalogue HT accessories.

Type	CR 16	CR 16 - ZA
Max. force, axial pushing (static)	500 N	500 N
Max. force, axial pulling (static)	220 N	220 N
Max. force, axial pushing (dynamic)	200 N	200 N
Max. force, axial pulling (dynamic)	100 N	100 N
Max. payload, radial dynamic	350 N	350 N
Max. payload, radial static	800 N	800 N

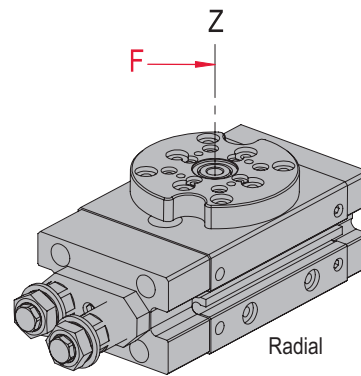
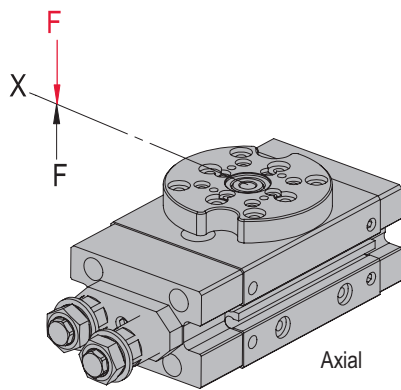

## Load diagrams

Axial static

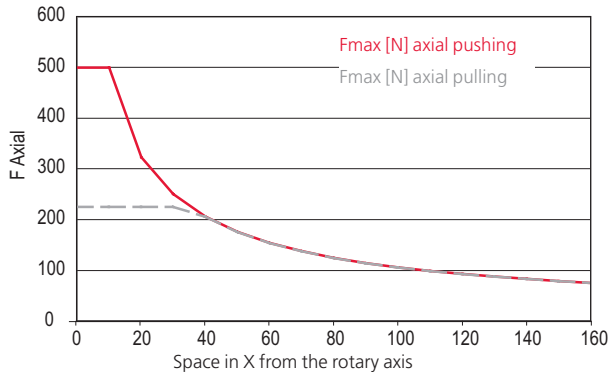

Axial dynamic

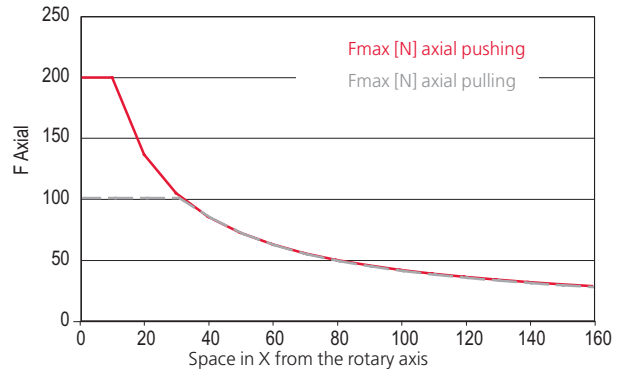

Radial static

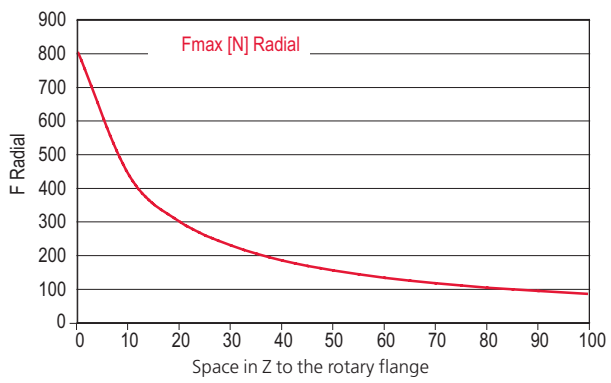

Radial dynamic

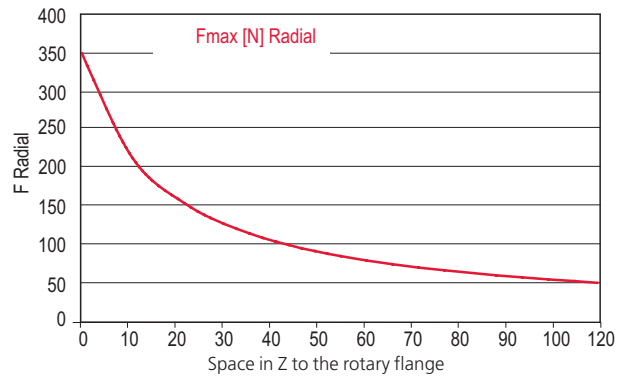

Rotation time

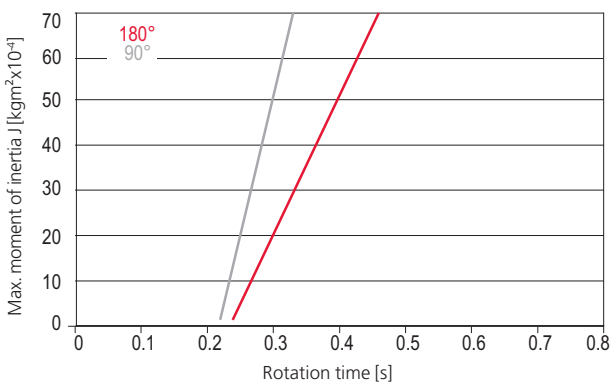

Type	CR 16-D	CR 16-ZA-D
Max. force, axial pushing (static)	500 N	500 N
Max. force, axial pulling (static)	180 N	180 N
Max. force, axial pushing (dynamic)	200 N	200 N
Max. force, axial pulling (dynamic)	70 N	70 N
Max. payload, radial dynamic	350 N	350 N
Max. payload, radial static	800 N	800 N

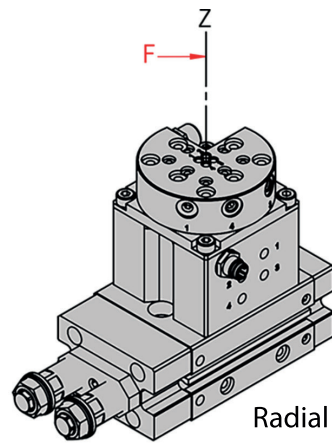
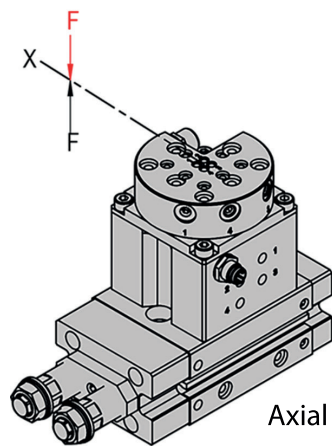

## Load diagrams

Axial static

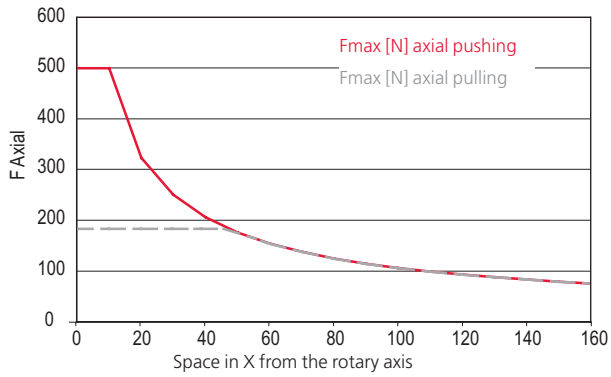

Axial dynamic

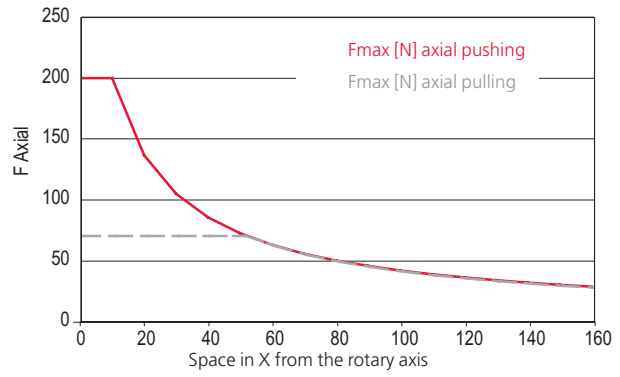

Radial static

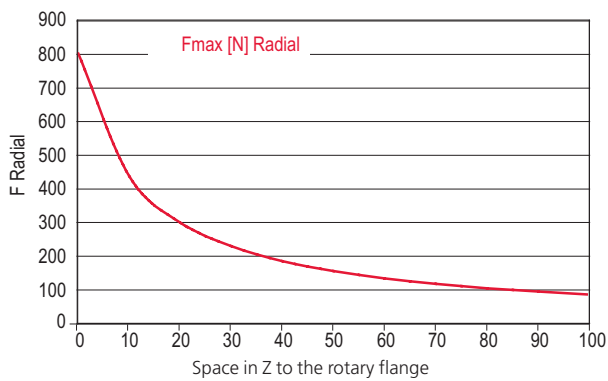

Radial dynamic

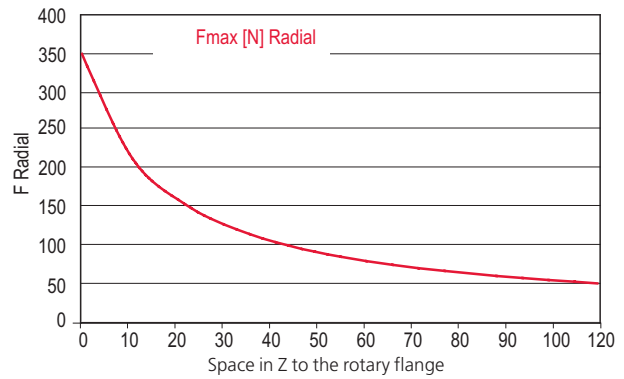

Rotation time

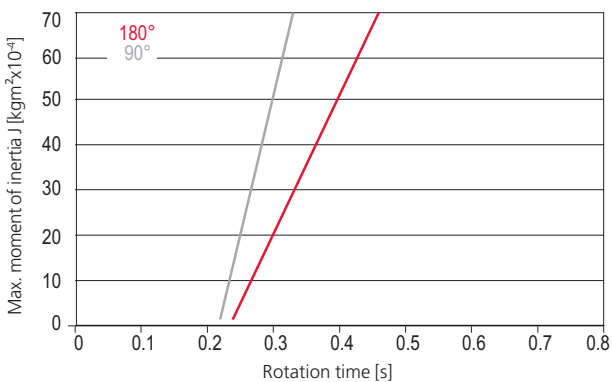

# Rotary modules compact CR

## CR 20

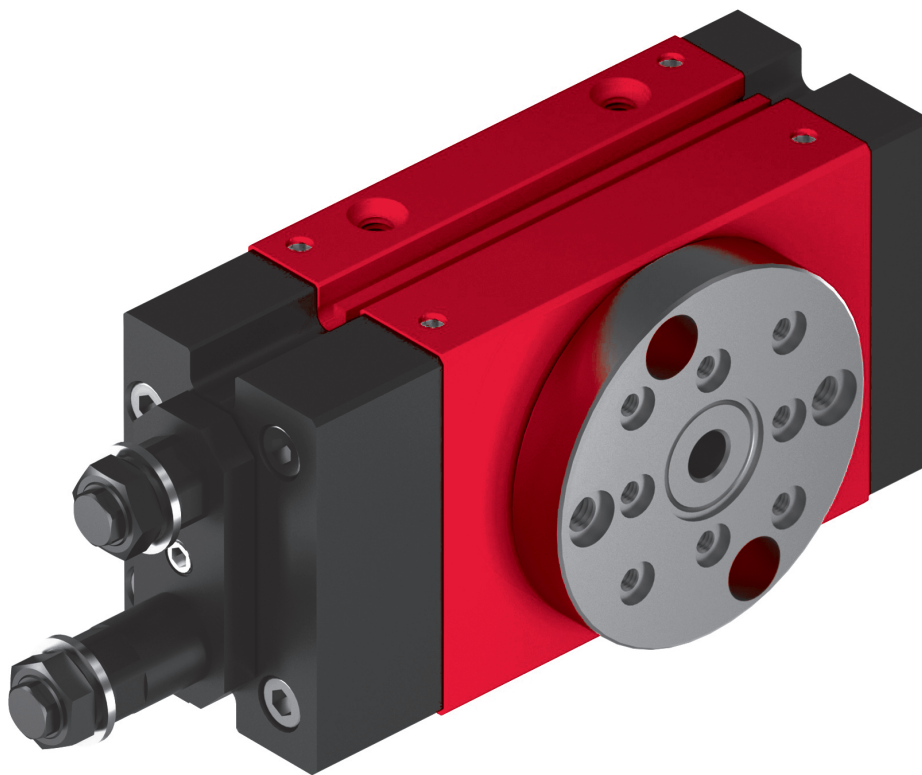

- Compact design
- Optionally with intermediate position
- High mass inertias

# Dimensions and dimension drawings

CR 20

Type	CR 20	CR 20 - ZA
A	Bore fitting	Bore fitting
P	M5	M5
P1	Clockwise	Clockwise
P2	Anti-clockwise	Anti-clockwise

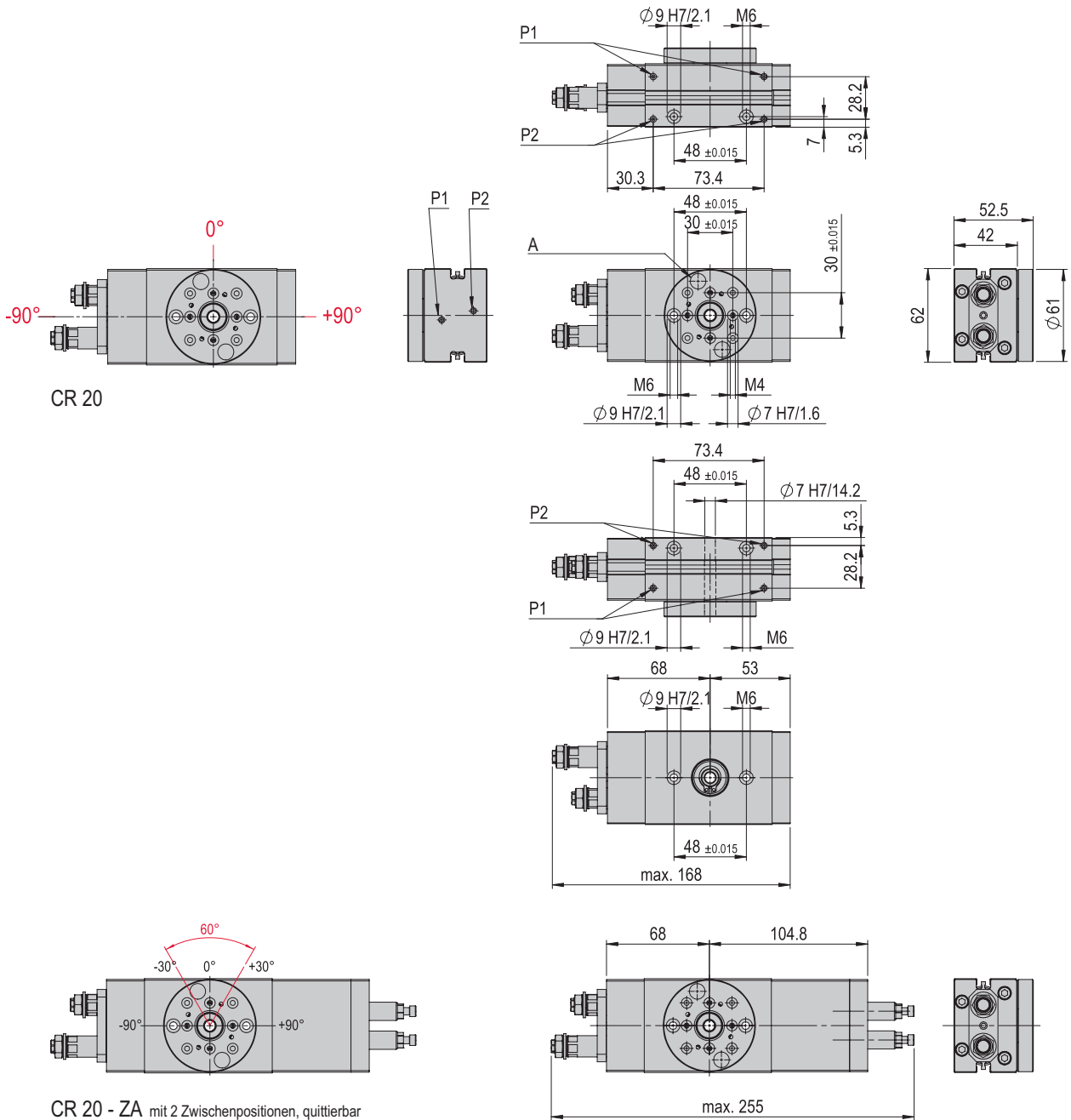

CR 20 - ZA mit 2 Zwischenpositionen, quittierbar

The flange hole patterns shown are in the  $0^\circ$  position for all modules. The flange rotates  $95^\circ$  to the left and  $95^\circ$  to the right.

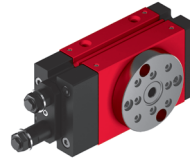

CR 20	
Attachment grid	48 mm
Attachment thread	M6
Operating pressure	6 +/- 2 bar
Air connection P	M5
Operating temperature	0 - 50 °C
Storage temperature	0 - 50 °C
Humidity	< 90 %
Medium filtered compressed air	10 - 40 µm

Type	CR 20	CR 20 - ZA
<b>Order number</b>	<b>50112943</b>	<b>50112945</b>
Net weight	1.28 kg	1.6 kg
Air consumption (180°)	0.003 NL	0.003 NL
Angle of rotation	0-180 °	0-180 °
Min. rotation time 180°	0.35 s	0.35 s
Noise level	54 dB (A)	54 dB (A)
Angle accuracy	+/- 0.05 °	+/- 0.05 °
Torque	2.2 Nm	2.2 Nm
Max. moment of inertia	*350 kgcm <sup>2</sup>	*350 kgcm <sup>2</sup>
Positions	2	4
Mounting position	↕	↕

The technical data refer to a nominal pressure of 6 bar under Afag standard test conditions.

Note: If a turning force acts against the direction of rotation in the end position, a drive with twice the theoretical torque should be selected. The module can be operated with lubricated or dry air. It is possible to switch from dry to lubricated but not vice versa. Cleanroom class ISO 14644-1, class ISO 7

\* Observe swivel time diagram

### Included in the delivery

(Catalogue HT accessories)

- 2x Centering bushing Ø7x3
- 2x Centering bushing Ø9x4
- 2x Special screw M6 x 36/8
- 2x Shock absorber SD M10x1 -4
- 4x O-ring 2.5x0.62 mm
- 2x Set screw M5x4

### Accessories

(Catalogue HT accessories)

- INI c10x28.5-Em-PNP-NO-M8x1

Warranty: 24 months following commissioning, but a maximum of 27 months following delivery



# Dimensions and dimension drawings

CR 20-D

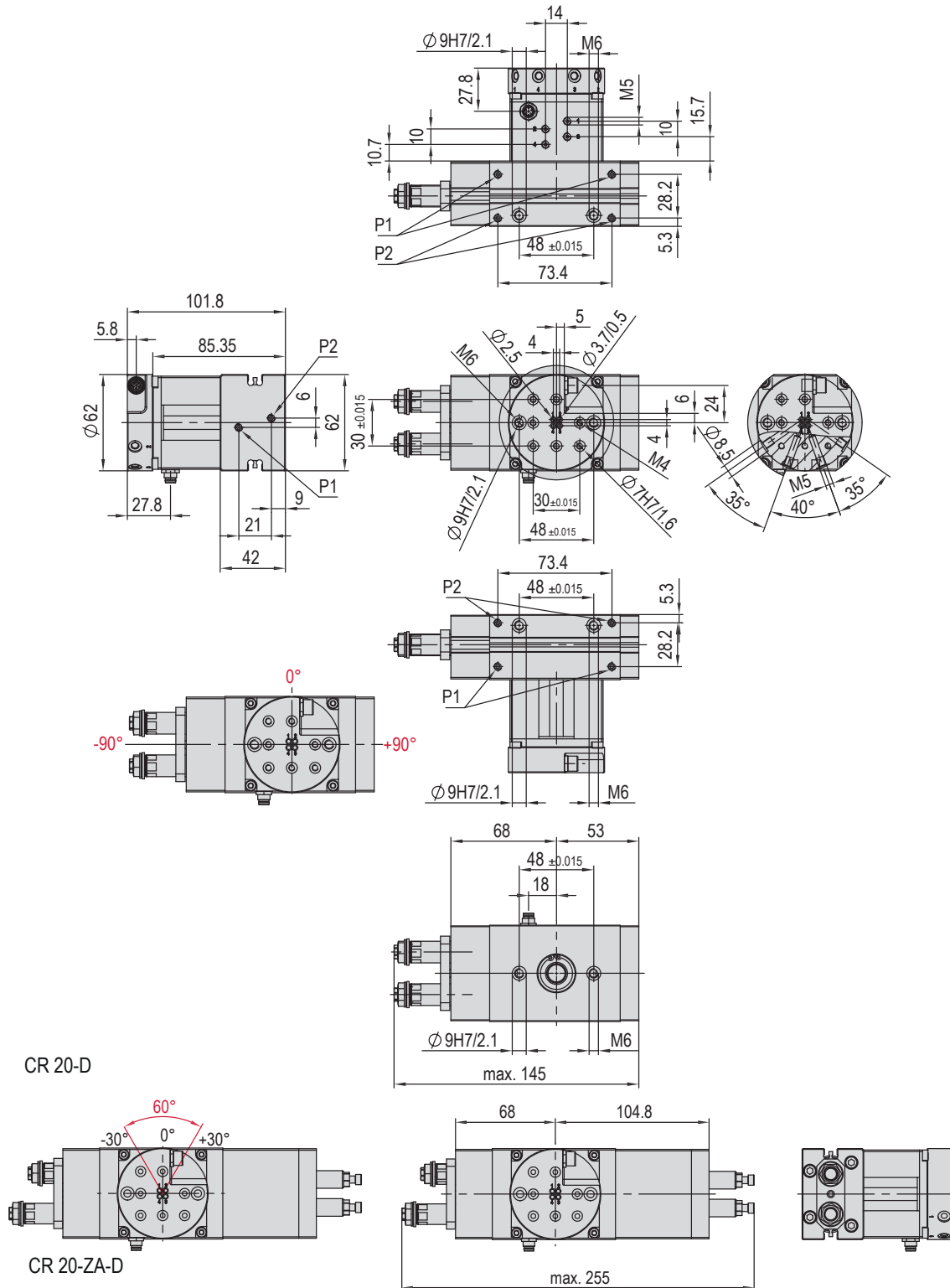

Type	CR 20-D	CR 20-ZA-D
A	Bore fitting	Bore fitting
P	M5	M5
P1	Clockwise	Clockwise
P2	Anti-clockwise	Anti-clockwise

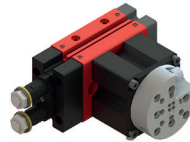

The flange hole patterns shown are in the 0° position for all modules. The flange rotates 95° to the left and 95° to the right.



CR 20-D	
Attachment grid	48 mm
Attachment thread	M6
Operating pressure	6 +/- 2 bar
Air connection P	M5
Operating temperature	0 - 50 °C
Storage temperature	0 - 50 °C
Humidity	< 90 %
Medium filtered compressed air	10 - 40 µm

Type	CR 20-D	CR 20-ZA-D
<b>Order number</b>	<b>50433055</b>	<b>50433058</b>
Net weight	1.68 kg	1.99 kg
Air consumption (180°)	0.003 NL	0.003 NL
Angle of rotation	0-180 °	0-180 °
Electrical feed-through	6 x 1 A	6 x 1 A
Rotary supply fluids	4 x M5	4 x M5
Min. rotation time 180°	0.35 s	0.35 s
Noise level	54 dB (A)	54 dB (A)
Angle accuracy	+/- 0.05 °	+/- 0.05 °
Torque	1.8 Nm	1.8 Nm
Max. moment of inertia	*350 kgcm <sup>2</sup>	*350 kgcm <sup>2</sup>
Positions	2	4
Mounting position		

The technical data refer to a nominal pressure of 6 bar under Afag standard test conditions.

Note: If a turning force acts against the direction of rotation in the end position, a drive with twice the theoretical torque should be selected. The module can be operated with lubricated or dry air. It is possible to switch from dry to lubricated but not vice versa. Cleanroom class ISO 14644-1, class ISO 7

\* Observe swivel time diagram

### Included in the delivery

(Catalogue HT accessories)

- 2x Centering bushing Ø9x4
- 2x Special screw M6 x 36/8
- 2x Shock absorber SD M10x1 -4
- 4x O-ring 2.5x0.62 mm
- 2x Set screw M5x4

### Accessories

(Catalogue HT accessories)

- INI c10x28.5-Em-PNP-NO-M8x1
- Sensor act. cable-6pol-female-5m-0-open-1
- Sensor act. cable-6pol-female-6m-0-open-1

Warranty: 24 months following commissioning, but a maximum of 27 months following delivery

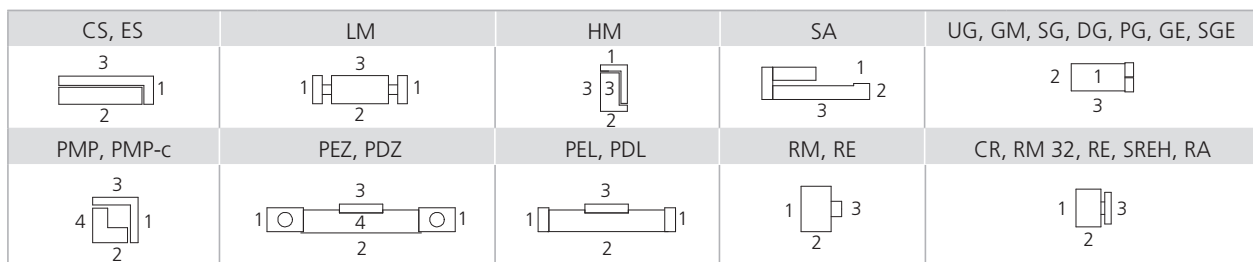
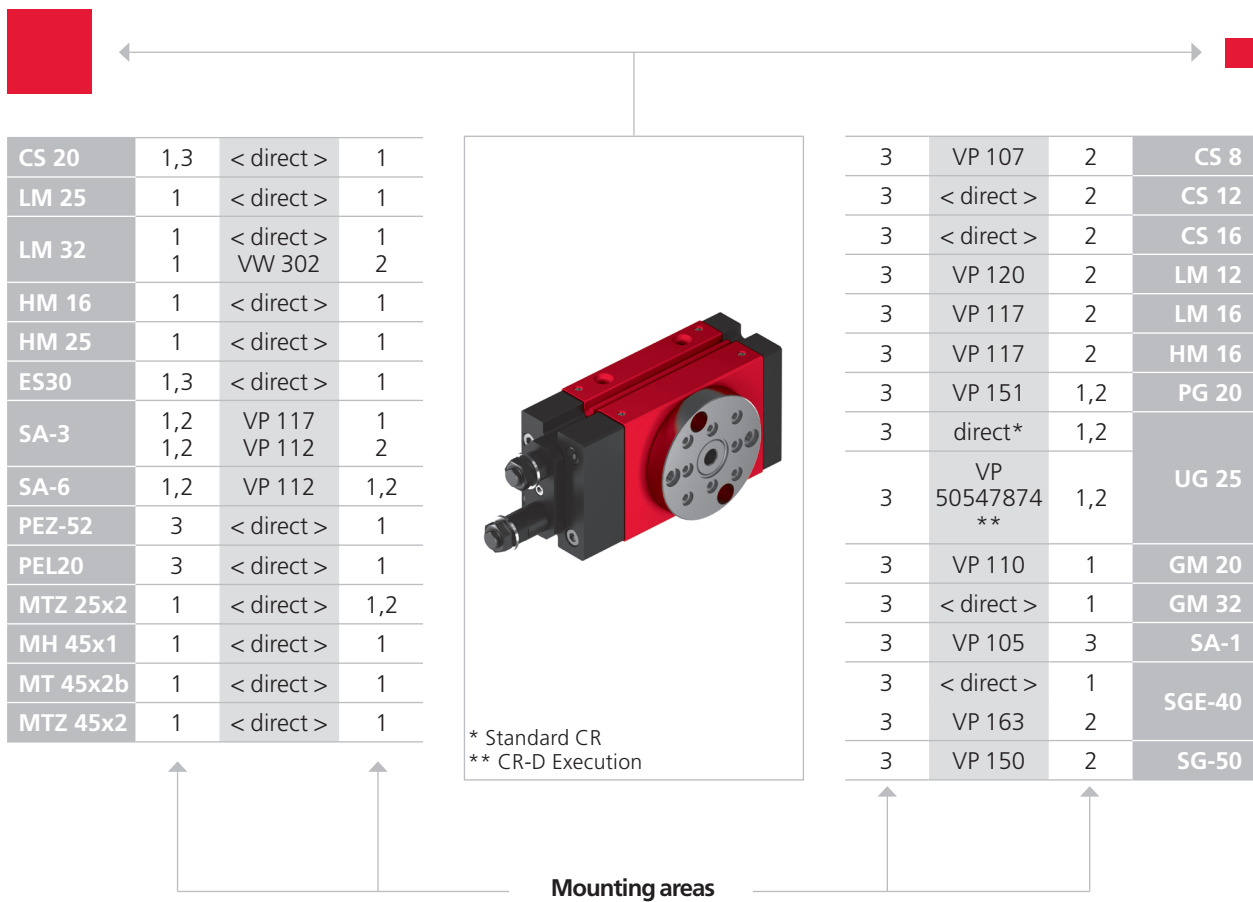

Note that there might be different mounting positions from one module to another one.  
The required connection elements and the range of support columns are depicted in the catalogue HT accessories.

Type	CR 20	CR 20 - ZA
Max. force, axial pushing (static)	900 N	900 N
Max. force, axial pulling (static)	250 N	250 N
Max. force, axial pushing (dynamic)	250 N	250 N
Max. force, axial pulling (dynamic)	120 N	120 N
Max. payload, radial dynamic	400 N	400 N
Max. payload, radial static	1000 N	1000 N

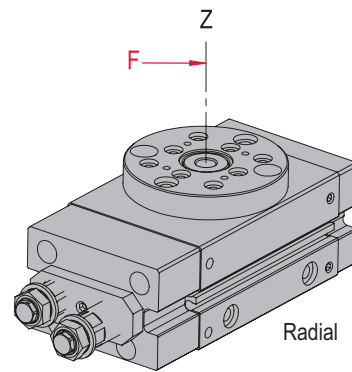
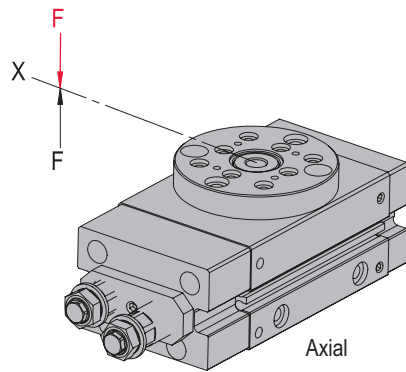

## Load diagrams

Axial static

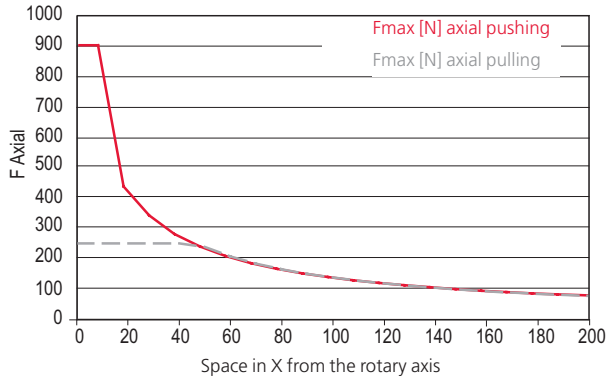

Axial dynamic

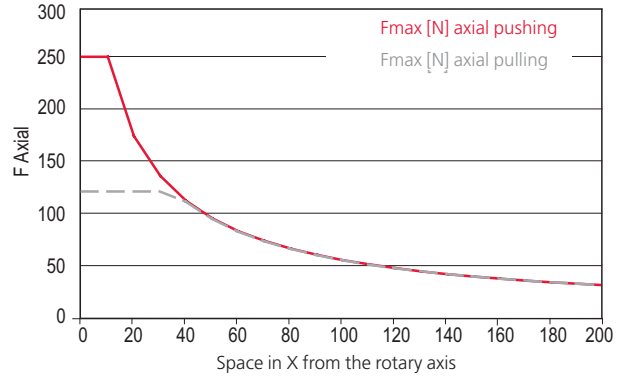

Radial static

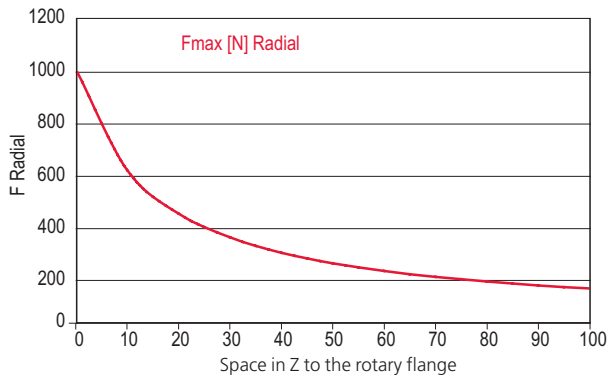

Radial dynamic

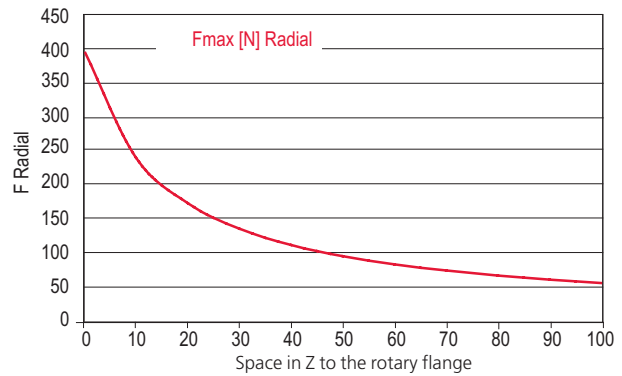

Rotation time

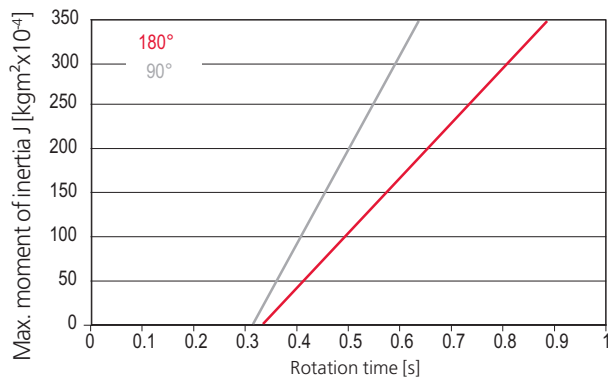

Type	CR 20-D	CR 20-ZA-D
Max. force, axial pushing (static)	700 N	700 N
Max. force, axial pulling (static)	350 N	350 N
Max. force, axial pushing (dynamic)	230 N	230 N
Max. force, axial pulling (dynamic)	160 N	160 N
Max. payload, radial dynamic	400 N	400 N
Max. payload, radial static	1000 N	1000 N

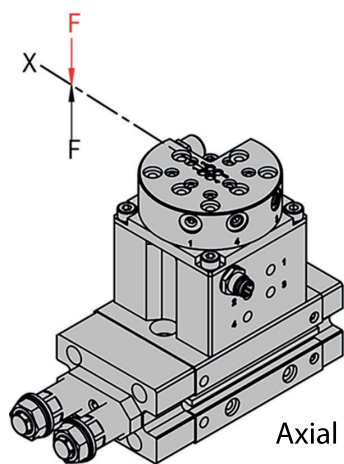

Axial

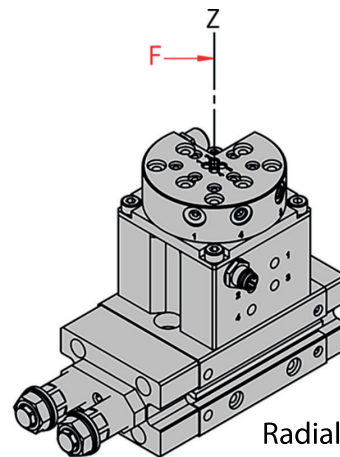

Radial

## Load diagrams

Axial static

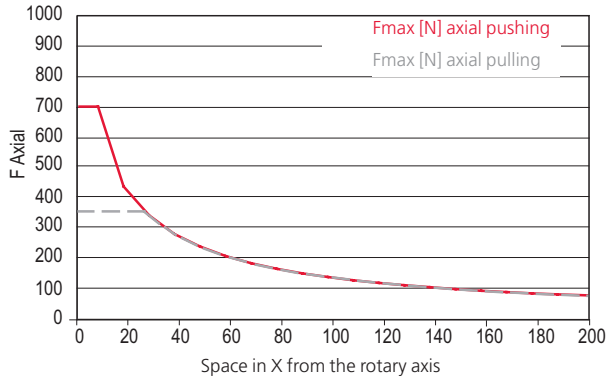

Axial dynamic

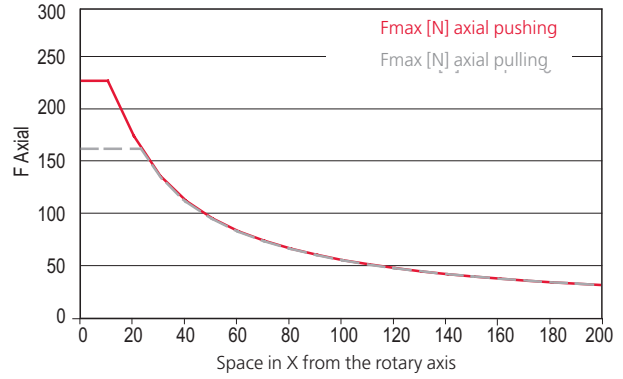

Radial static

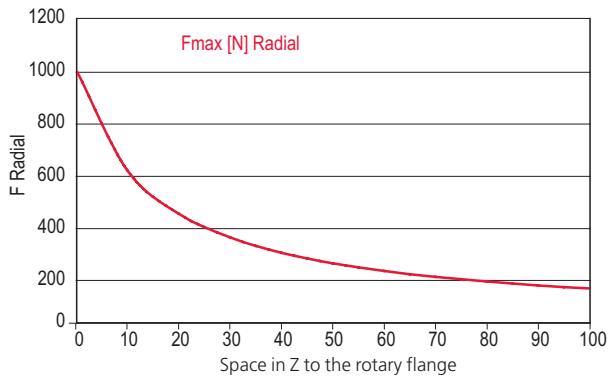

Radial dynamic

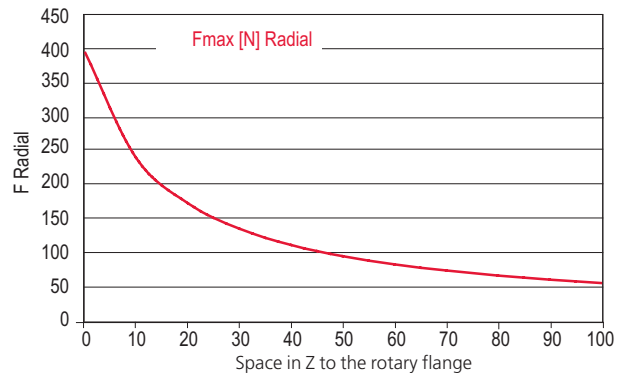

Rotation time

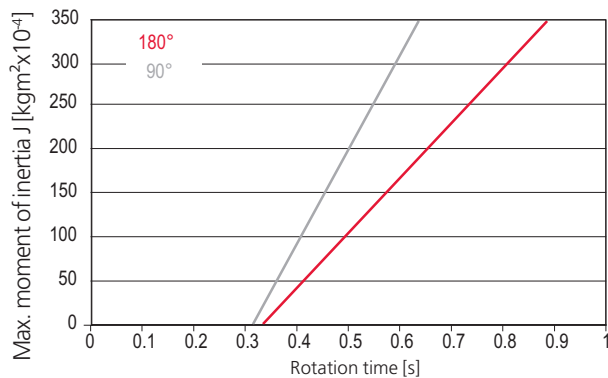

# Rotary modules compact CR

## CR 25

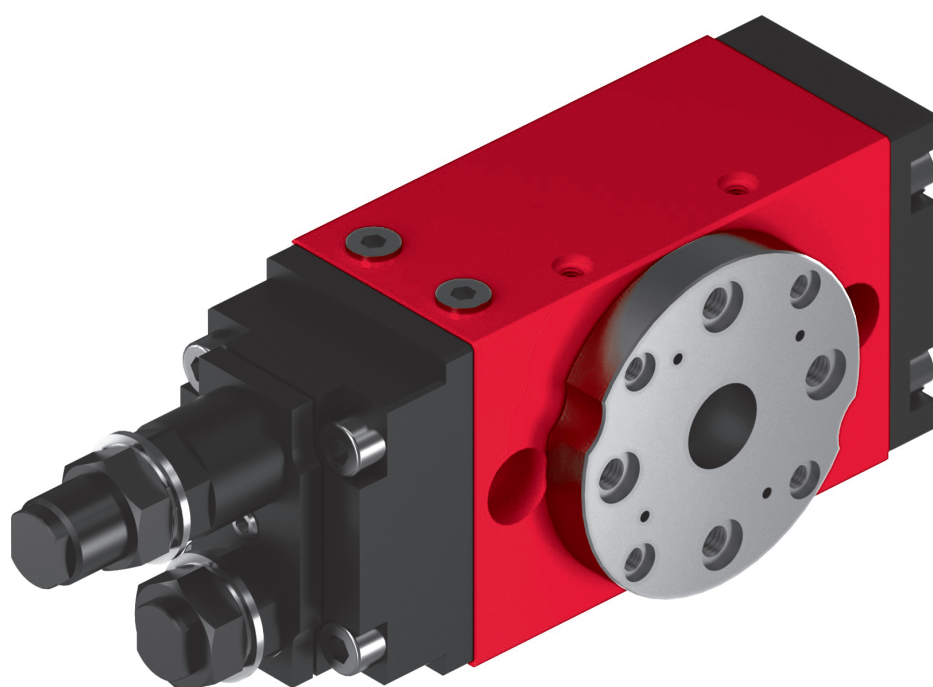

- Compact design
- Large mounting flange
- High mass inertias



Type	CR 25
P	G 1/8 "
P1	Clockwise
P2	Counterclockwise

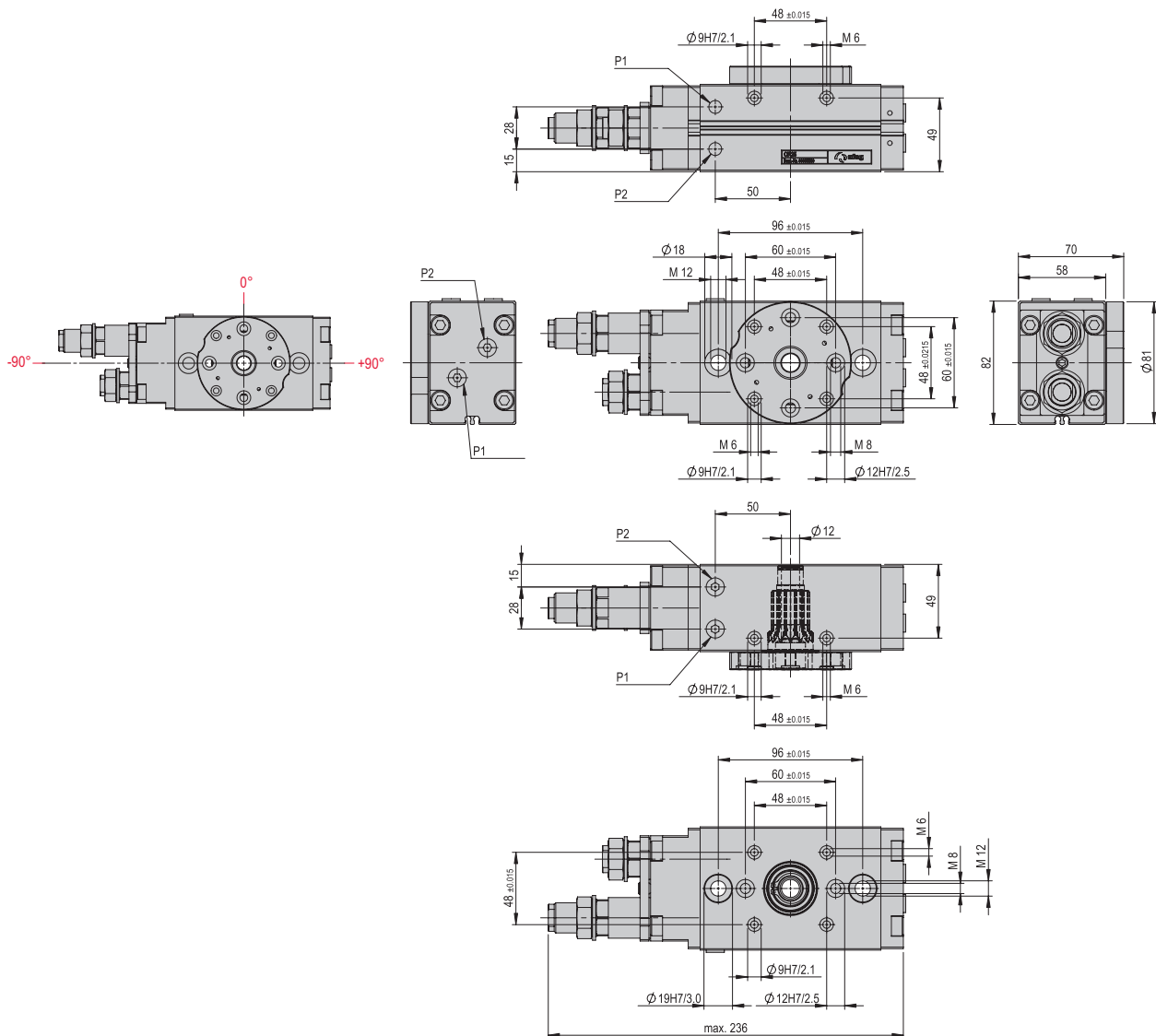

The flange hole patterns shown are in the 0° position for all modules. The flange rotates 100° to the left and 100° to the right.

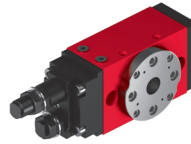

CR 25	
Attachment grid	96 mm
Attachment grid alternative	60 mm
Attachment thread	M10 pass - M12 from below
Attachment thread alternative	M8
Operating pressure	6 +/- 2 bar
Air connection P	G 1/8 "
Operating temperature	0 - 50 °C
Storage temperature	0 - 50 °C
Humidity	< 90 %
Medium filtered compressed air	10 - 40 µm

Type	CR 25
<b>Order number</b>	<b>50254300</b>
Net weight	3.28 kg
Air consumption (180°)	0.389 NL
Angle of rotation	0-180 °
Min. rotation time 180°	0.44 s
Noise level	54 dB (A)
Angle accuracy	+/- 0.05 °
Torque	6.2 Nm
Max. moment of inertia	*4000 kgcm <sup>2</sup>
Positions	2
Mounting position	⊕

The technical data refer to a nominal pressure of 6 bar under Afag standard test conditions.

Note: If a turning force acts against the direction of rotation in the end position, a drive with twice the theoretical torque should be selected.

The module can be operated with lubricated or dry air. It is possible to switch from dry to lubricated but not vice versa.

Cleanroom class ISO 14644-1, class ISO 7

\*Observe rotation time diagram

### Included in the delivery

(Catalogue HT accessories)

- 2x Centering bushing Ø19x5.8
- 2x Mounting screw M10x70
- 2x Shock absorber SD M20x1.5 -1

### Accessories

(Catalogue HT accessories)

- INI c10x28.5-Em-PNP-NO-M8x1

Warranty: 24 months following commissioning, but a maximum of 27 months following delivery

afag.com

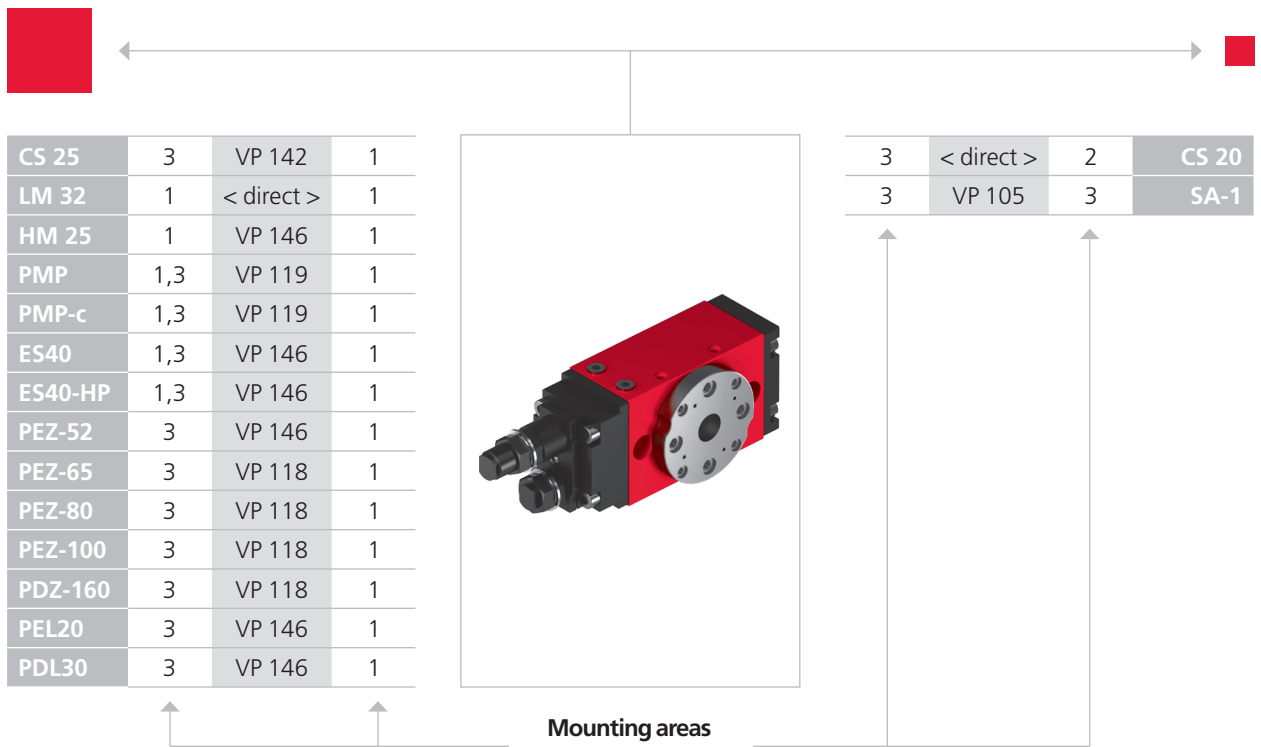

CS, ES	LM	HM	SA	UG, GM, SG, DG, PG, GE, SGE
PMP, PMP-c	PEZ, PDZ	PEL, PDL	RM, RE	CR, RM 32, RE, SREH, RA

Note that there might be different mounting positions from one module to another one.  
 The required connection elements and the range of support columns are depicted in the catalogue HT accessories.

Type	CR 25
Max. force, axial pushing static	2075 N
Max. force, axial pulling static	800 N
Max. force, axial pushing dynamic	430 N
Max. force, axial pulling dynamic	200 N
Max. payload, radial dynamic	891 N
Max. payload, radial static	3635 N

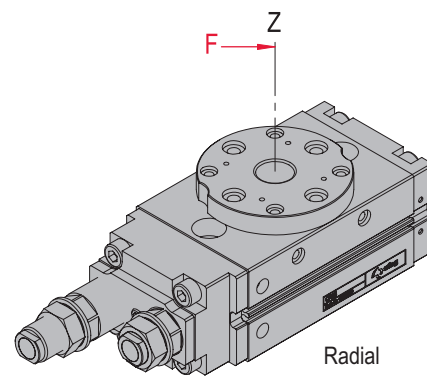
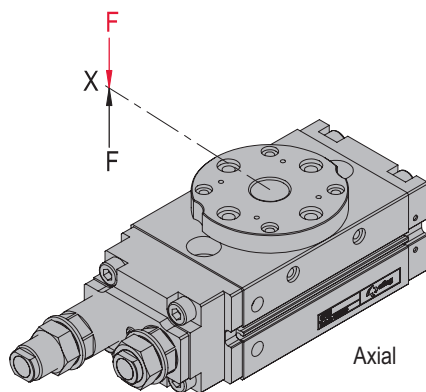

## Load diagrams

Axial dynamic

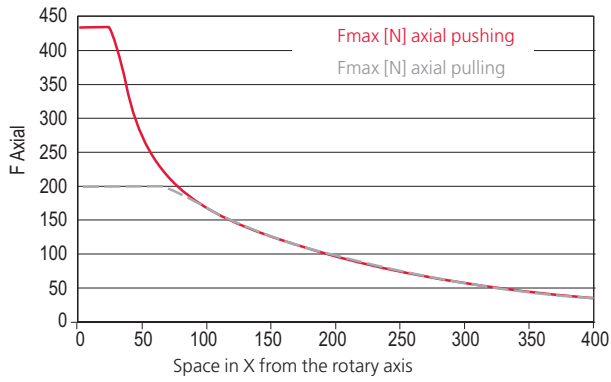

Axial static

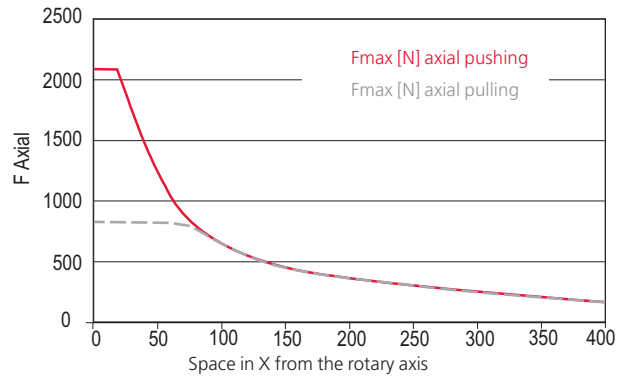

Radial dynamic

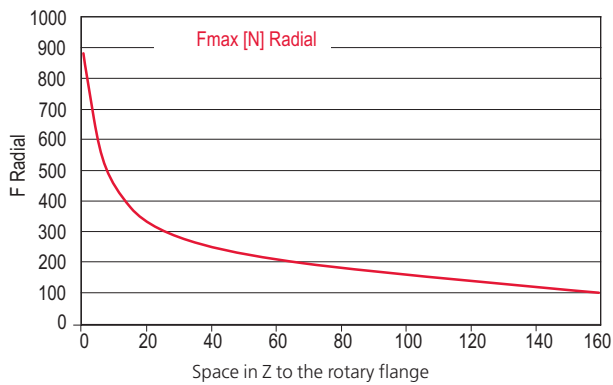

Radial static

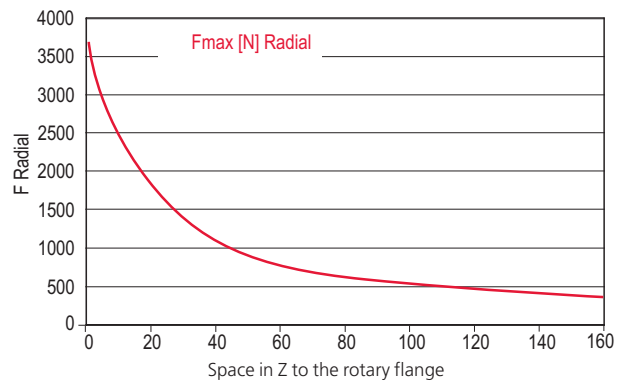

Rotation time

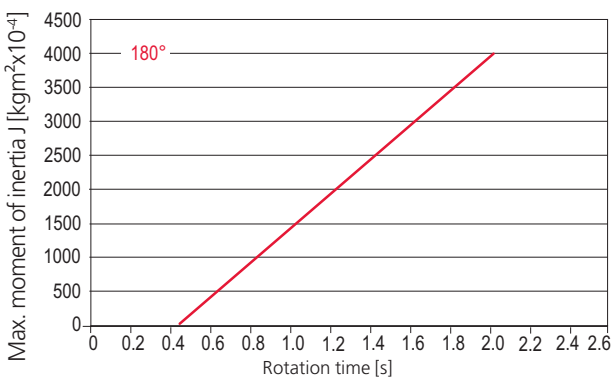

# Rotary modules compact CR

## CR 32

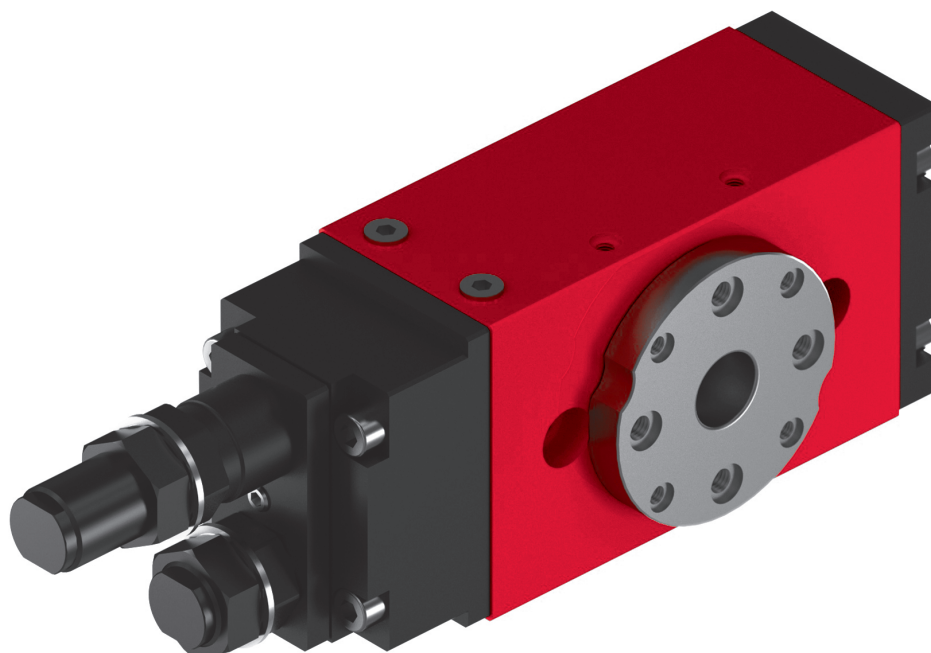

- Compact design
- Large mounting flange
- High mass inertias

Type	CR 32
P	G 1/8 "
P1	Clockwise
P2	Counterclockwise

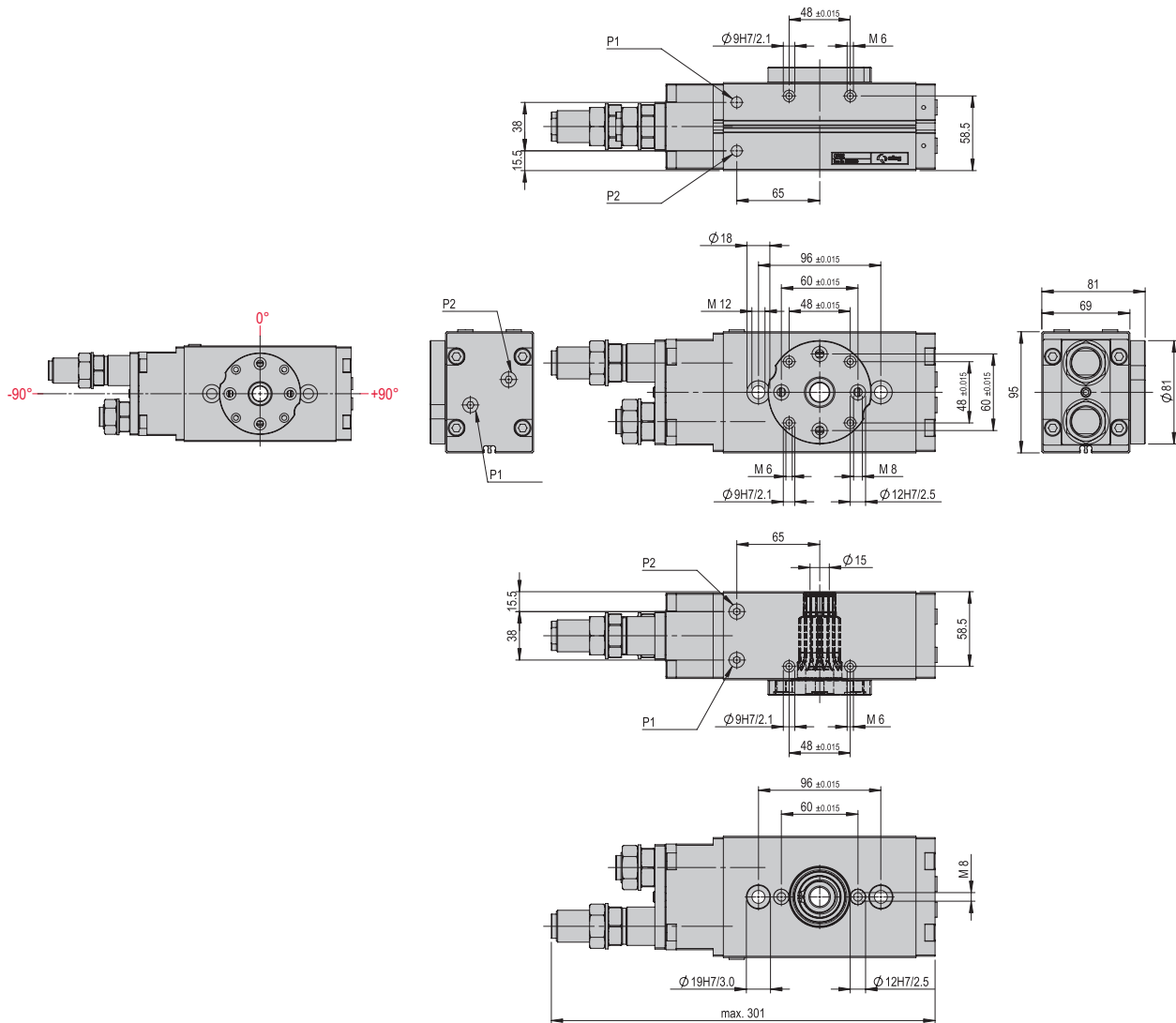

The flange hole patterns shown are in the 0° position for all modules. The flange rotates 100° to the left and 100° to the right.

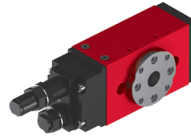

CR 32	
Attachment grid	96 mm
Attachment grid alternative	60 mm
Attachment thread	M10 pass M12 from below
Attachment thread alternative	M8
Operating pressure	6 +/- 2 bar
Air connection P	G 1/8 "
Operating temperature	0 - 50 °C
Storage temperature	0 - 50 °C
Humidity	< 90 %
Medium filtered compressed air	10 - 40 µm

Type	CR 32
<b>Order number</b>	<b>50254301</b>
Net weight	5.395 kg
Air consumption (180°)	0.849 NL
Angle of rotation	0-180 °
Min. rotation time 180°	0.66 s
Noise level	54 dB (A)
Angle accuracy	+/- 0.05 °
Torque	13.5 Nm
Max. moment of inertia	*10000 kgcm <sup>2</sup>
Positions	2
Mounting position	⊕

The technical data refer to a nominal pressure of 6 bar under Afag standard test conditions.

Note: If a turning force acts against the direction of rotation in the end position, a drive with twice the theoretical torque should be selected.

The module can be operated with lubricated or dry air. It is possible to switch from dry to lubricated but not vice versa.

Cleanroom class ISO 14644-1, class ISO 7

\*Observe rotation time diagram

### Included in the delivery

(Catalogue HT accessories)

- 2x Centering bushing Ø19x5.8
- 2x Mounting screw M10x80
- 2x Shock absorber SD M25x1.5 -1

### Accessories

(Catalogue HT accessories)

- INI c10x28.5-Em-PNP-NO-M8x1

Warranty: 24 months following commissioning, but a maximum of 27 months following delivery

afag.com



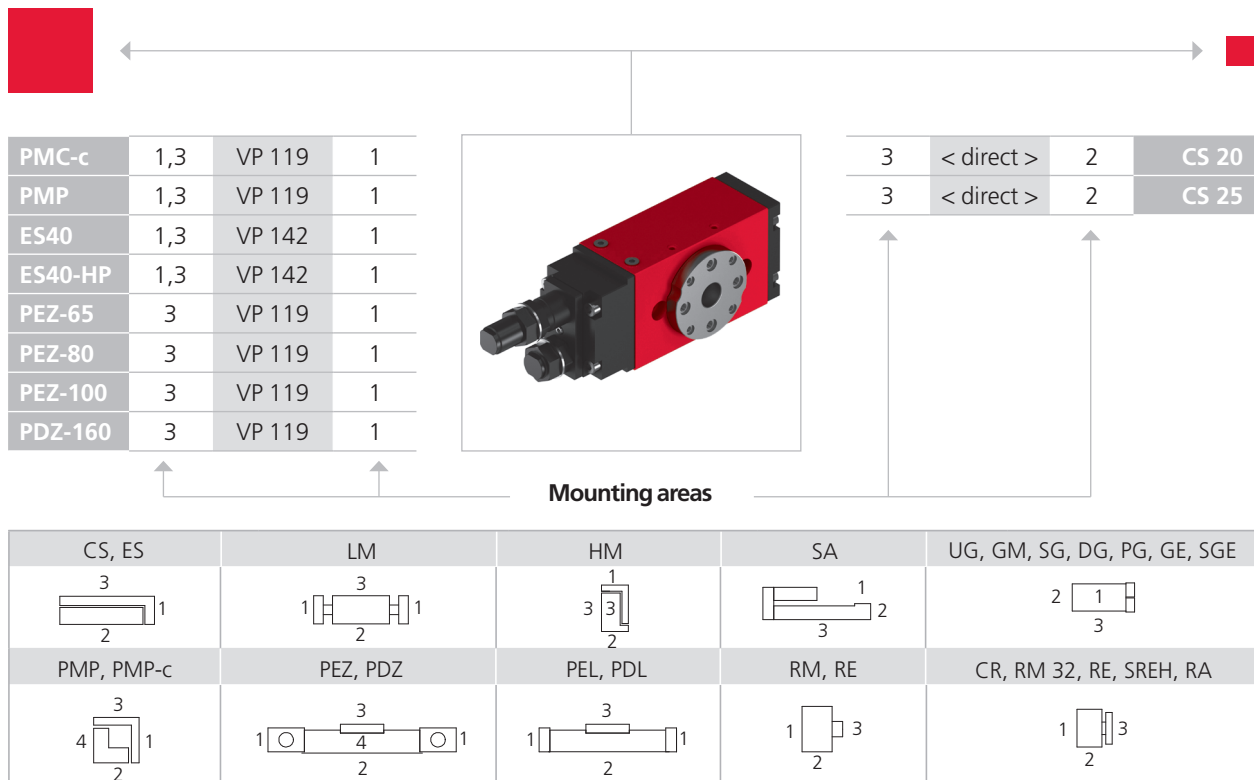

Note that there might be different mounting positions from one module to another one.  
 The required connection elements and the range of support columns are depicted in the catalogue HT accessories.

Type	CR 32
Max. force, axial pushing static	2550 N
Max. force, axial pulling static	1600 N
Max. force, axial pushing dynamic	252 N
Max. force, axial pulling dynamic	370 N
Max. payload, radial dynamic	1983 N
Max. payload, radial static	8733 N

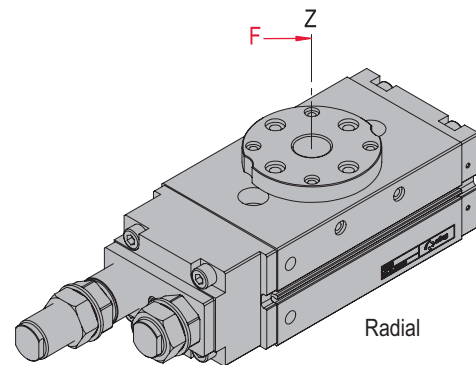
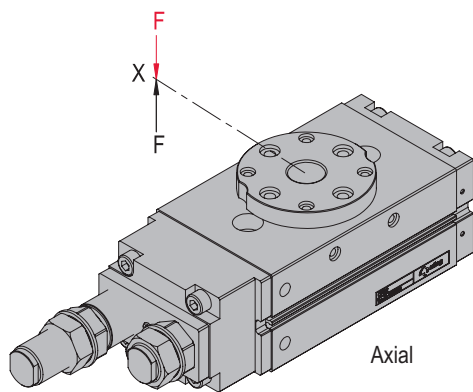

## Load diagrams

Axial dynamic

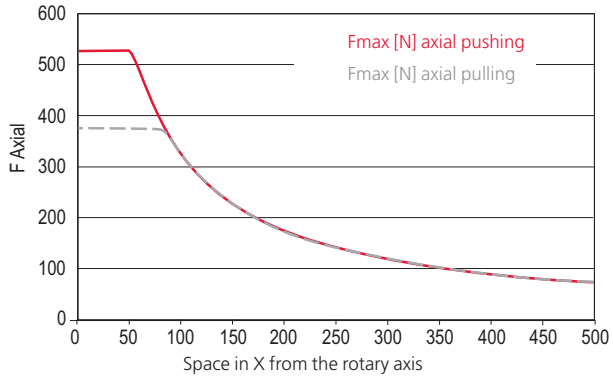

Axial static

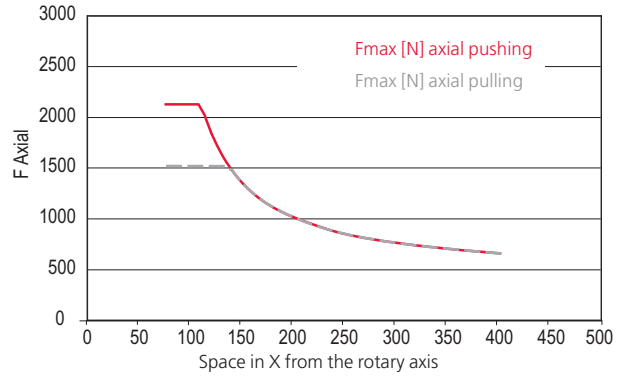

Radial dynamic

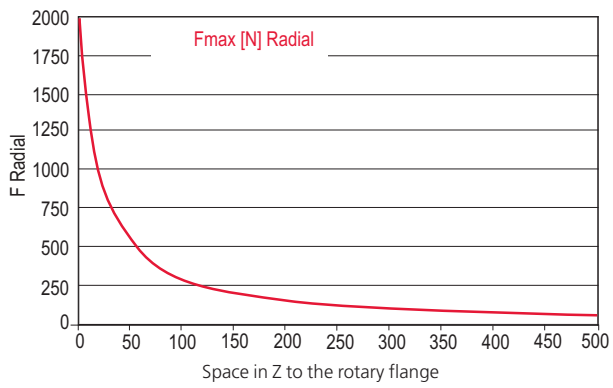

Radial static

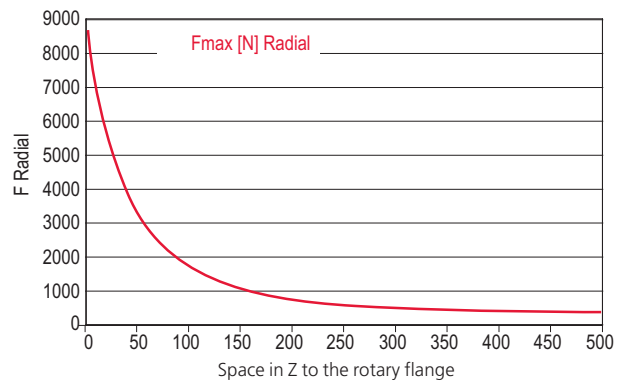

Rotation time

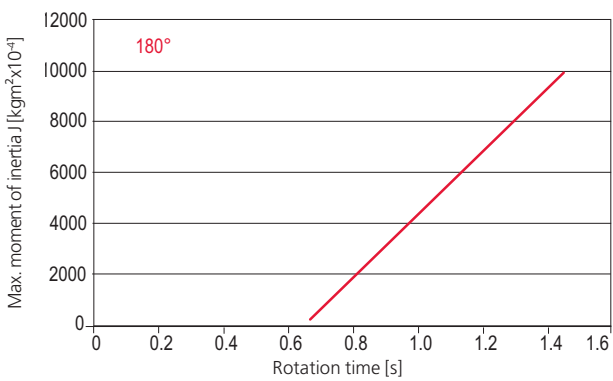

# Accessories CR

## Connection plate VP CR 16-20-D-UG 25

<b>Order number</b>	<b>50547874</b>
<b>Net weight</b>	0.049 kg

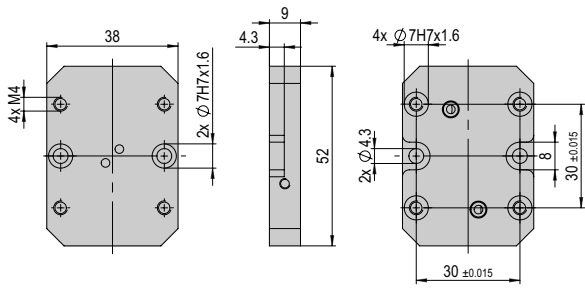

### Included in the delivery

- 2x Centering bushing Ø7x3
- 2x Mounting screw M4x12

## Connection plate VP CR 16-20-D-UG 20

<b>Order number</b>	<b>50547875</b>
<b>Net weight</b>	0.043 kg

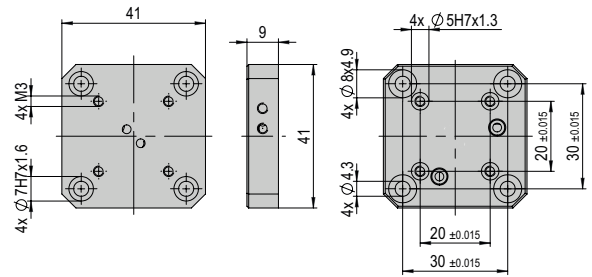

### Included in the delivery

- 2x Centering bushing Ø7x3
- 3x Mounting screw M4x10