

Rotary gripper DG

DG 16 & DG 20

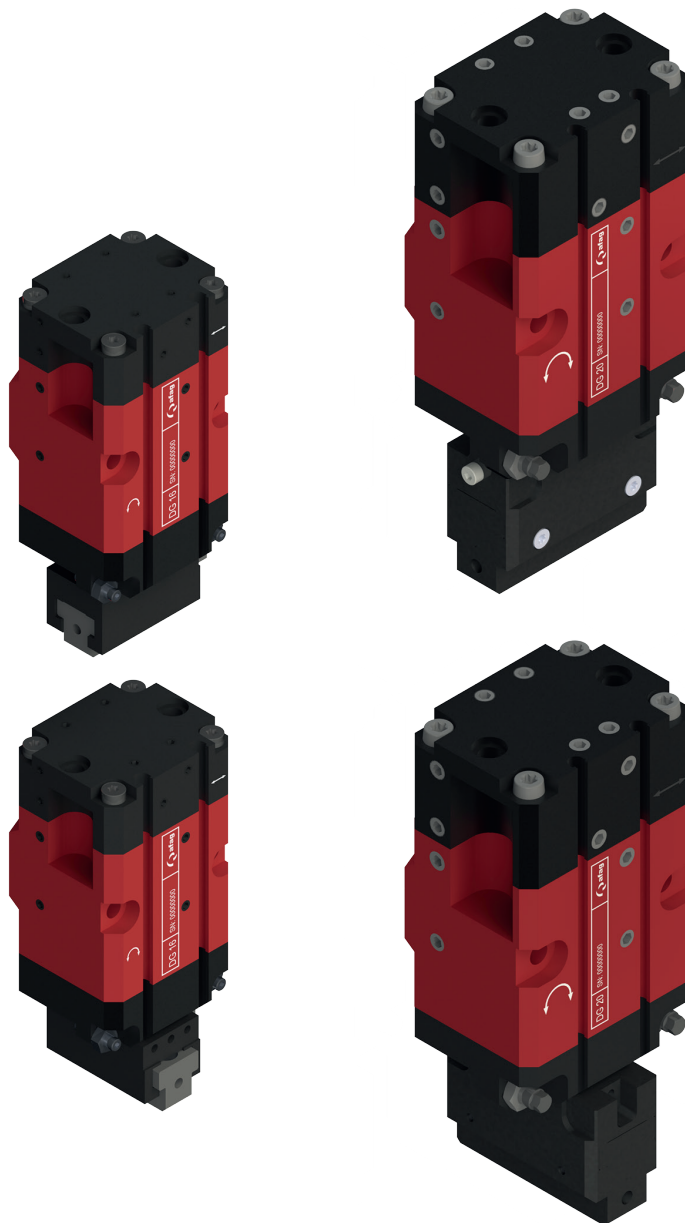
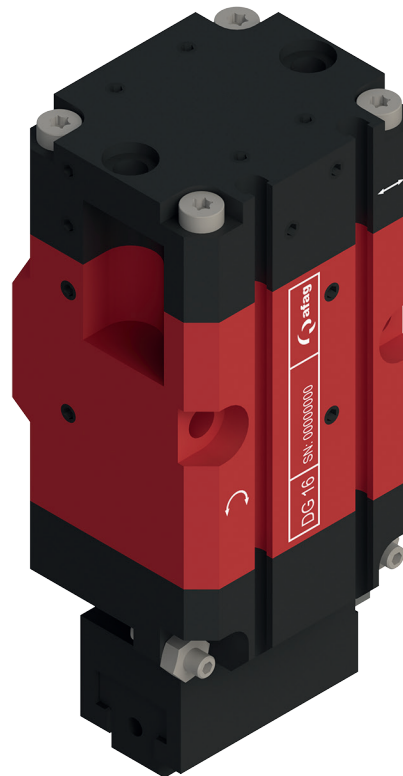

Table of contents: DG

Rotary gripper DG	Page
DG 16	167
DG 20	175
Accessories DG	182

Rotary gripper DG

DG 16



- Shortest rotary gripper within its performance class
- Diverse air connections
- Precise jaw guidance

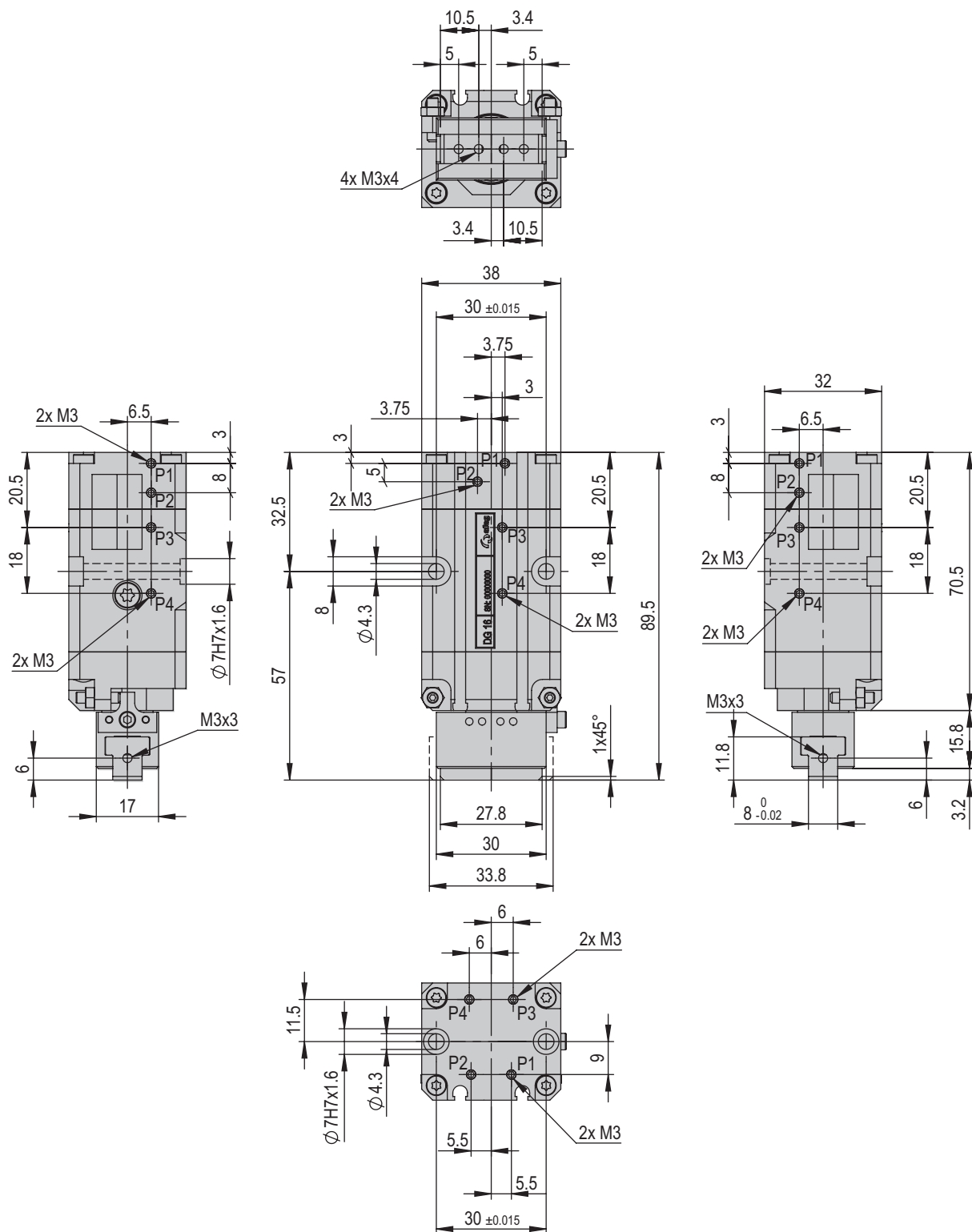



DG 16	
Attachment grid	30 mm
Operating pressure	6 +/- 1 bar
Air connection P	M3
Operating temperature	10 - 40 °C
Storage temperature	0 - 50 °C
Humidity	< 90 %

Type	DG 16
Order number	50294010
Jaw stroke	2 x 3 mm
Net weight	0.275 kg
Max. payload	0.5 kg/cm ²
Gripping force	35 N
Cylinder Ø gripper	16 / 4 mm
Cylinder Ø rotation	20 / 10 mm
Sensor, gripping	open
Sensor, rotating	0° / 180° oder 90°
Angle of rotation	180 °
Min. rotation time 180°	190 ms
Noise level	< 65 dB (A)
Repeat accuracy	+/- 0.03 mm
Angle accuracy	+/- 0.05 °
Torque	0.4 Nm
Mounting position	

The technical data refer to a nominal pressure of 6 bar under Afag standard test conditions.
The module can be operated with lubricated or dry air.
Cleanroom class ISO 14644-1, class ISO 7

Included in the delivery (Catalogue HT accessories)

- 2x Centering bushing Ø7x3
- 2x Mounting screw M4x16
- 2x Mounting screw M4x35
- 2x Set screw M3x3

Accessories

- End stop 90° DG 16 [p. 182]
 - Sensor holder mounting set DG 16 [p. 181]
- (Catalogue HT accessories)
- Compressed air connection straight M3 x 0.5
 - Compressed air connection angled M3 x 0.5
 - INI c10x19.5-Em-PNP-NO-M8x1

Warranty: 24 months following commissioning, but a maximum of 27 months following delivery

Dimensions & dimension drawing DG 16 (zero position 90°)

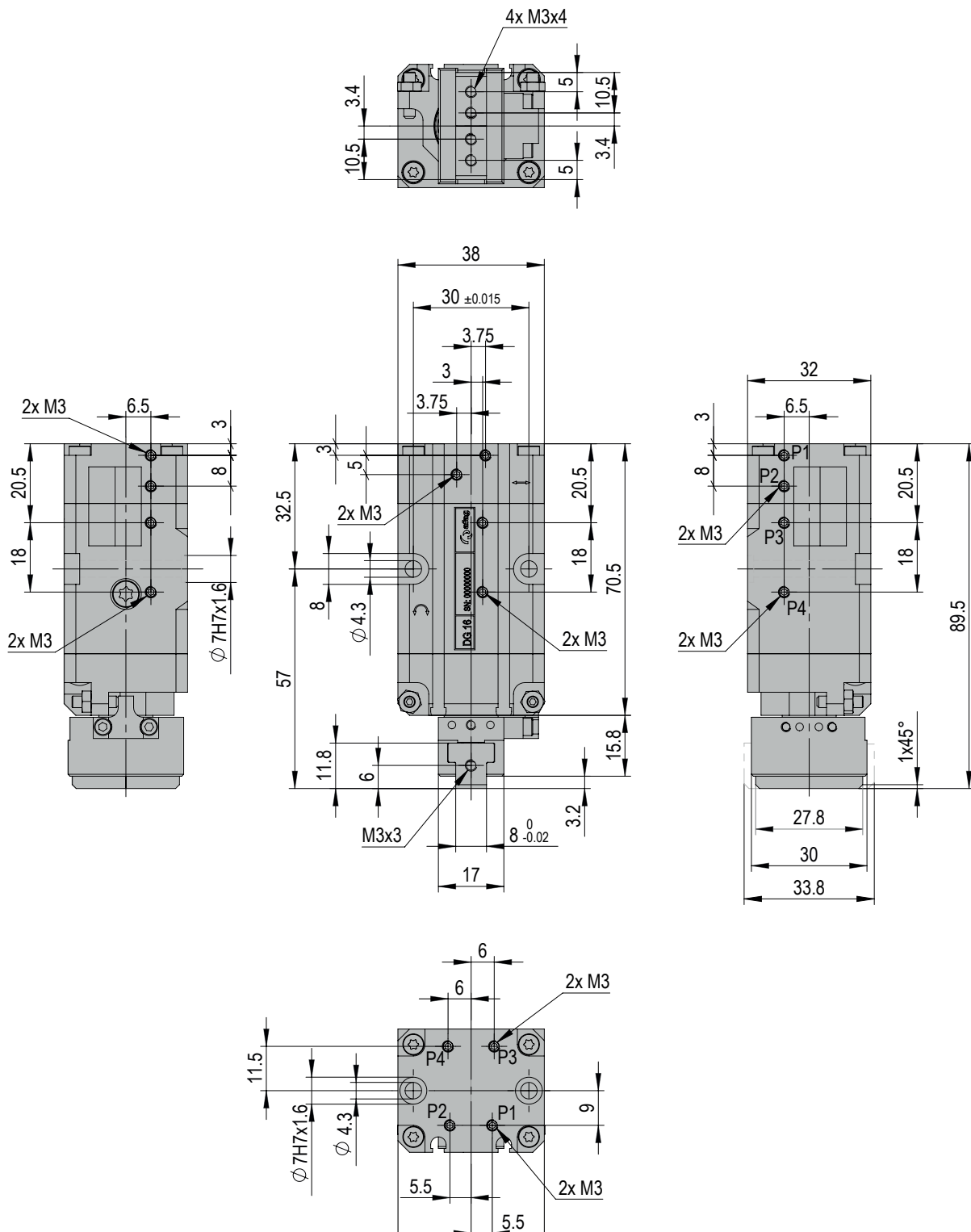

Technical data



DG 16 (zero position 90°)

DG 16 (zero position 90°)	
Attachment grid	30 mm
Operating pressure	6 +/- 1 bar
Air connection P	M3
Operating temperature	10 - 40 °C
Storage temperature	0 - 50 °C
Humidity	< 90 %

Type	DG 16 (zero position 90°)
Order number	50407663
Jaw stroke	2 x 3 mm
Net weight	0.275 kg
Max. payload	0.5 kg/cm ²
Gripping force	35 N
Cylinder Ø gripper	16 / 4 mm
Cylinder Ø rotation	20 / 10 mm
Sensor, gripping	open
Sensor, rotating	0° / 180° oder 90°
Angle of rotation	180 °
Min. rotation time 180°	190 ms
Noise level	< 65 dB (A)
Repeat accuracy	+/- 0.03 mm
Angle accuracy	+/- 0.05 °
Torque	0.4 Nm
Mounting position	

The technical data refer to a nominal pressure of 6 bar under Afag standard test conditions.
The module can be operated with lubricated or dry air.
Cleanroom class ISO 14644-1, class ISO 7

Included in the delivery (Catalogue HT accessories)

- 2x Centering bushing Ø7x3
- 2x Mounting screw M4x16
- 2x Mounting screw M4x35
- 2x Set screw M3x3

Accessories

- End stop 90° DG 16 zero position [p. 182]
 - Sensor holder mounting set DG 16 [p. 181]
- (Catalogue HT accessories)
- Compressed air connection straight M3 x 0.5
 - Compressed air connection angled M3 x 0.5
 - INI c10x19.5-Em-PNP-NO-M8x1

Warranty: 24 months following commissioning, but a maximum of 27 months following delivery

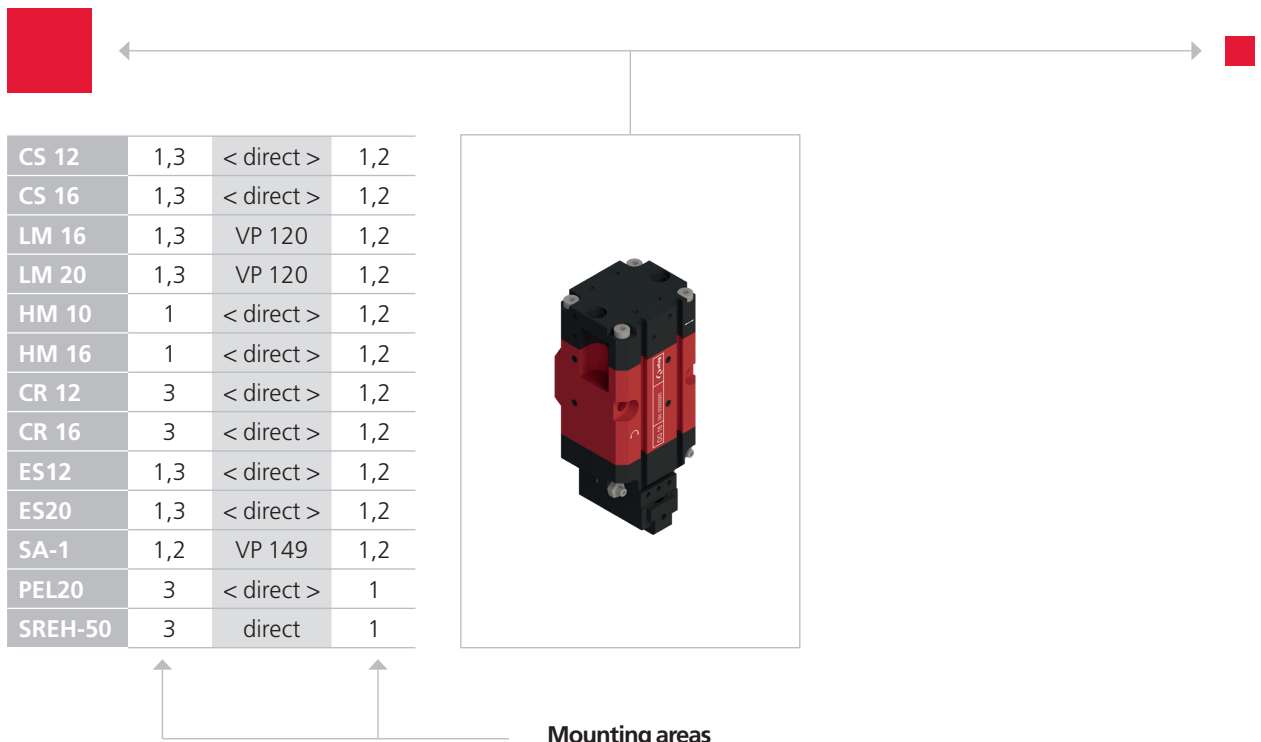

CS, ES	LM	HM	SA	UG, GM, SG, DG, PG, GE, SGE
PMP, PMP-c	PEZ, PDZ	PEL, PDL	RM, RE	CR, RM 32, RE, SREH, RA

Note that there might be different mounting positions from one module to another one.
 The required connection elements and the range of support columns are depicted in the catalogue HT accessories.

Type	DG 16
Max. static torque Mx	3 Nm
Max. static torque My	3 Nm
Max. static torque Mz	10 Nm
Max. static force Fz	50 N

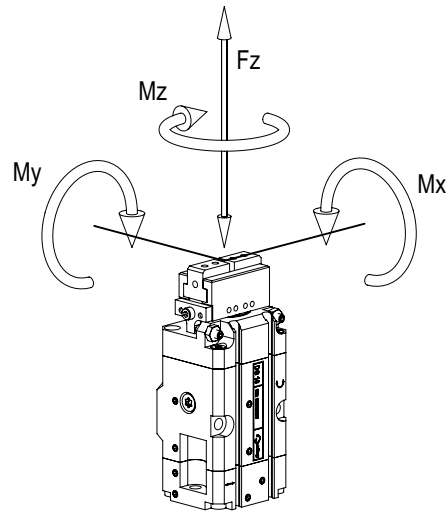

Rotation time diagram

Rotation time

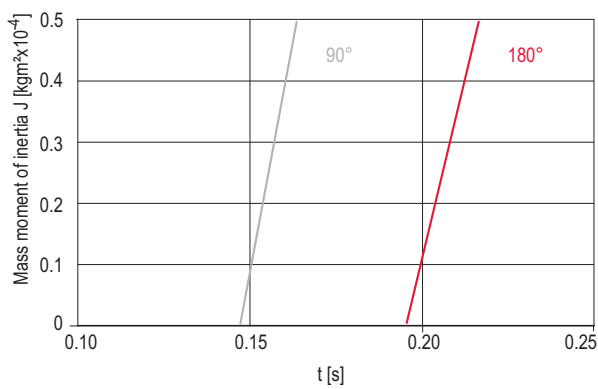

Centric gripping force diagrams, closing/opening

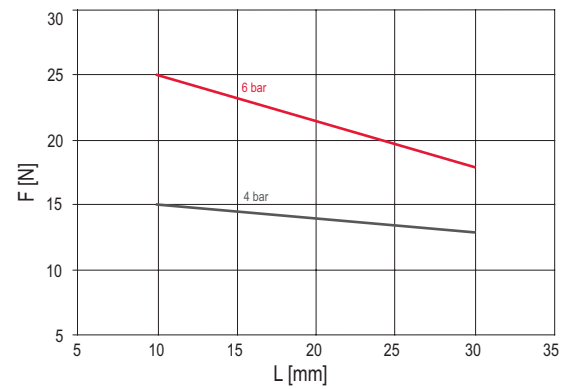

Rotary gripper DG

DG 20

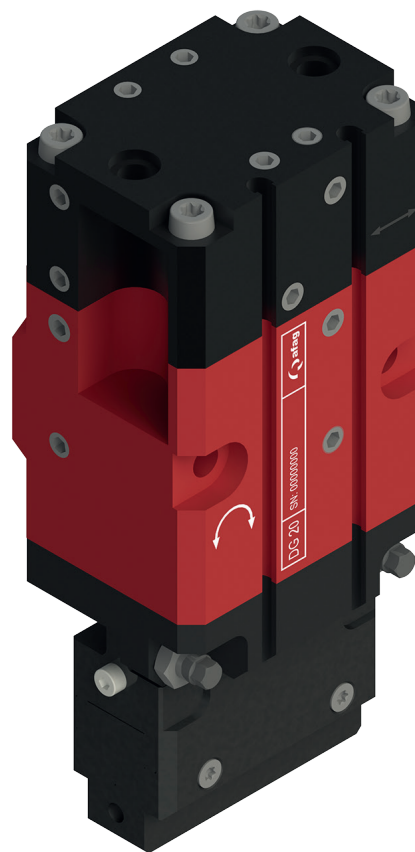

- Shortest rotary gripper within its performance class
- Diverse air connections
- Precise jaw guidance

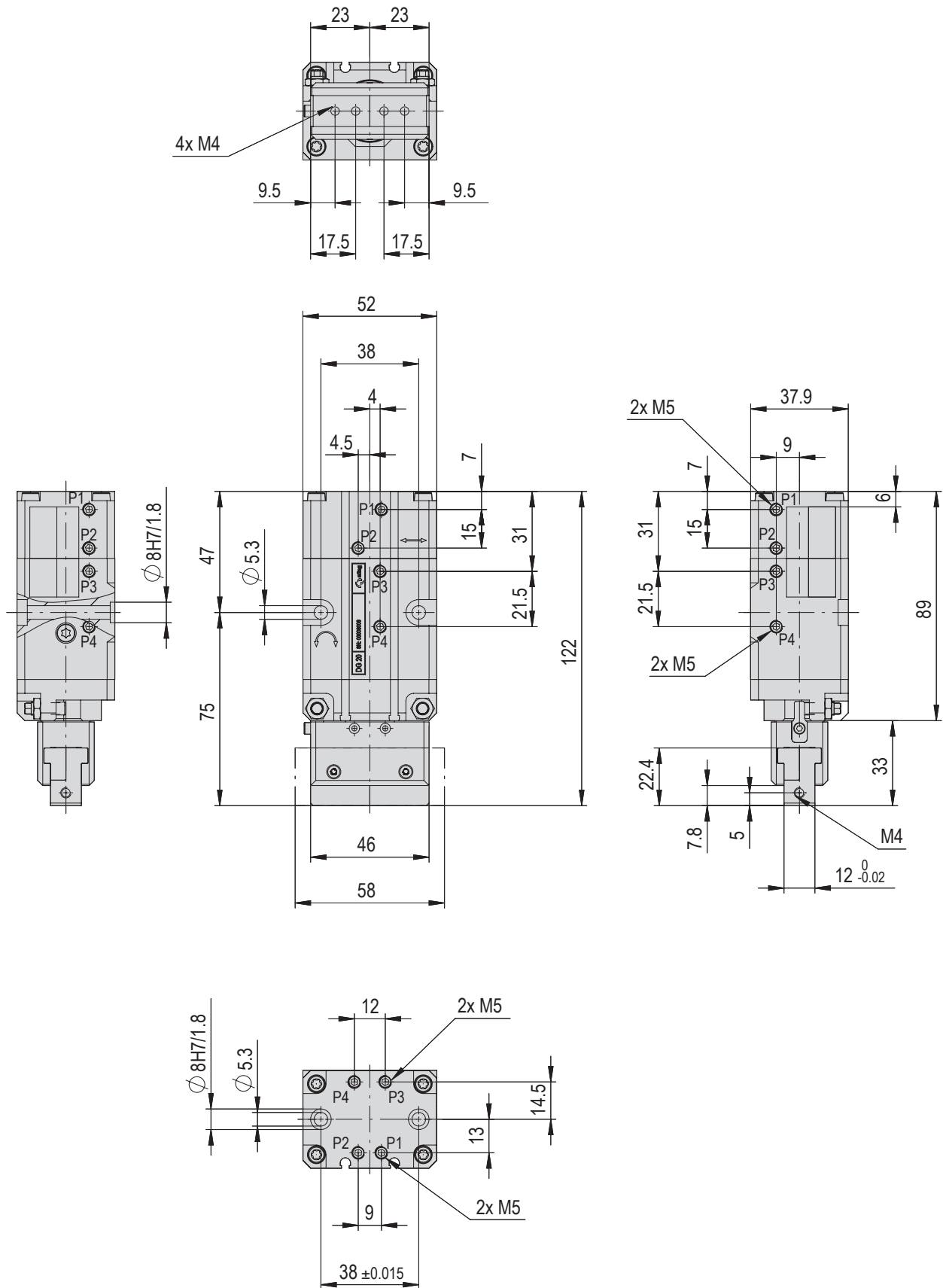



DG 20	
Attachment grid	38 mm
Operating pressure	6 +/- 1 bar
Air connection P	M5
Operating temperature	10 - 40 °C
Storage temperature	0 - 50 °C
Humidity	< 90 %

Type	DG 20
Order number	50432971
Jaw stroke	2 x 6 mm
Net weight	0.635
Max. payload	3.5 kgcm ²
Gripping force	60 N
Cylinder Ø gripper	20 / 6 mm
Cylinder Ø rotation	25 / 6 mm
Sensor, gripping	open
Sensor, rotating	0° / 180° oder 90°
Angle of rotation	180 °
Min. rotation time 180°	260 ms
Noise level	54 dB (A)
Repeat accuracy	+/- 0.03 mm
Angle accuracy	+/- 0.05 °
Torque	0.55 Nm
Mounting position	

The technical data refer to a nominal pressure of 6 bar under Afag standard test conditions.
The module can be operated with lubricated or dry air.
Cleanroom class ISO 14644-1, class ISO 7

Included in the delivery

(Catalogue HT accessories)

- 2x Centering bushing Ø8x3.5
- 2x Mounting screw w. socket head M5x16
- 2x Mounting screw M5x45
- 2x Set screw M5x4 brass
- 4x Set screw M5x4

Accessories

- End stop 90° DG20 [p. 183]
- Sensor holder mounting set DG 20 [p. 183]

(Catalogue HT accessories)

- INI c10x28.5-Em-PNP-NO-M8x1
- INI c10x19.5-Em-PNP-NO-M8x1

Warranty: 24 months following commissioning, but a maximum of 27 months following delivery

afag.com

Dimensions & dimension drawing DG 20 (zero position 90°)

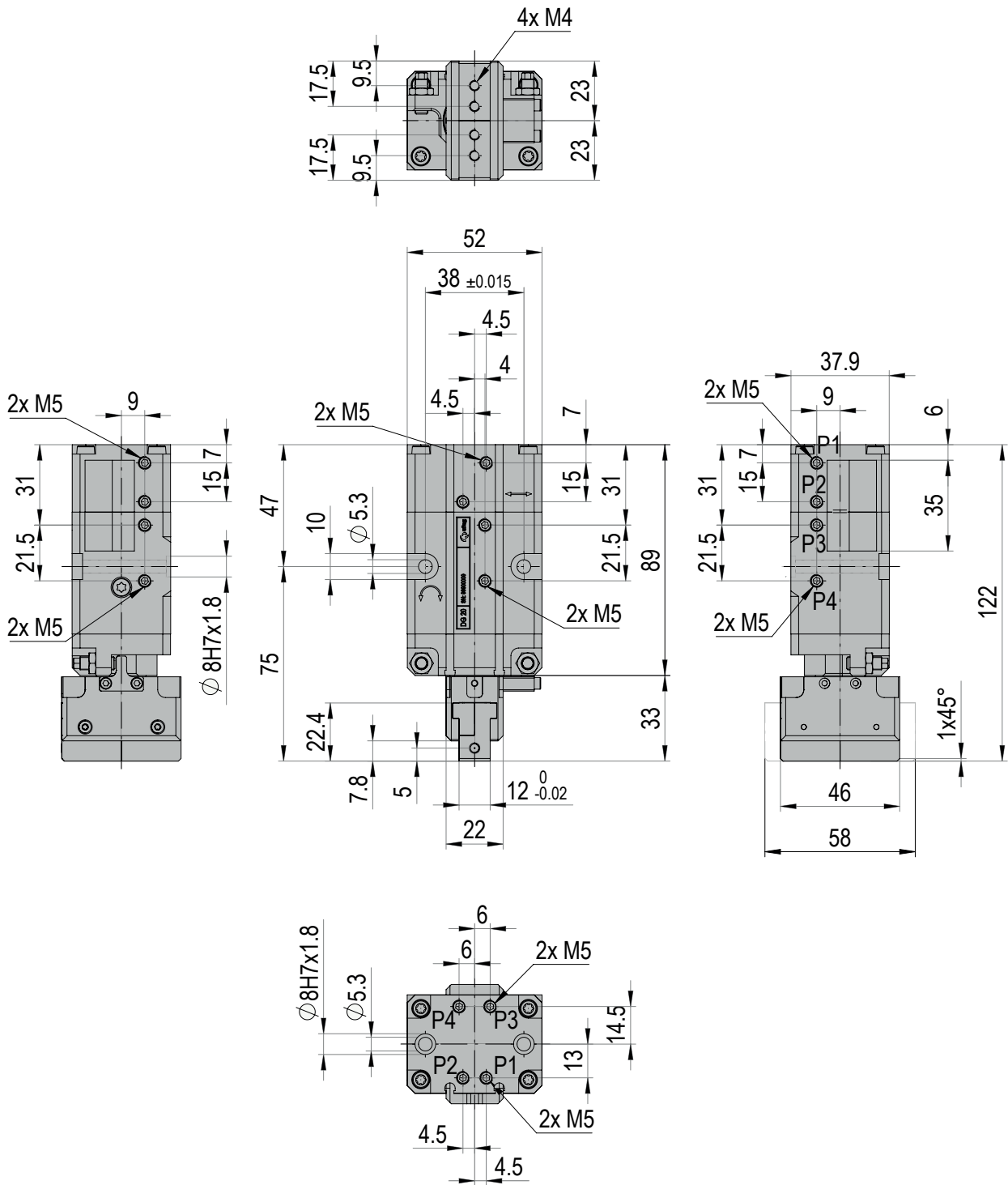

Technical data



DG 20 (zero position 90°)

DG 20 (zero position 90°)	
Attachment grid	38 mm
Operating pressure	6 +/- 1 bar
Air connection P	M5
Operating temperature	10 - 40 °C
Storage temperature	0 - 50 °C
Humidity	< 90 %

Type	DG 20 (zero position 90°)
Order number	50452096
Jaw stroke	2 x 6 mm
Net weight	0.635
Max. payload	3.5 kg/cm ²
Gripping force	60 N
Cylinder Ø gripper	20 / 6 mm
Cylinder Ø rotation	25 / 6 mm
Sensor, gripping	open
Sensor, rotating	0° / 180° oder 90°
Angle of rotation	180 °
Min. rotation time 180°	260 ms
Noise level	54 dB (A)
Repeat accuracy	+/- 0.03 mm
Angle accuracy	+/- 0.05 °
Torque	0.55 Nm
Mounting position	

The technical data refer to a nominal pressure of 6 bar under Afag standard test conditions.
The module can be operated with lubricated or dry air.
Cleanroom class ISO 14644-1, class ISO 7

Included in the delivery

(Catalogue HT accessories)

- 2x Centering bushing Ø8x3.5
- 2x Mounting screw w. socket head M5x16
- 2x Mounting screw M5x45
- 2x Set screw M5x4 brass
- 4x Set screw M5x4

Accessories

- End stop 90° DG20 zero position [p. 183]
- Sensor holder mounting set DG 20 [p. 183]

(Catalogue HT accessories)

- INI c10x28.5-Em-PNP-NO-M8x1
- INI c10x19.5-Em-PNP-NO-M8x1

Warranty: 24 months following commissioning, but a maximum of 27 months following delivery





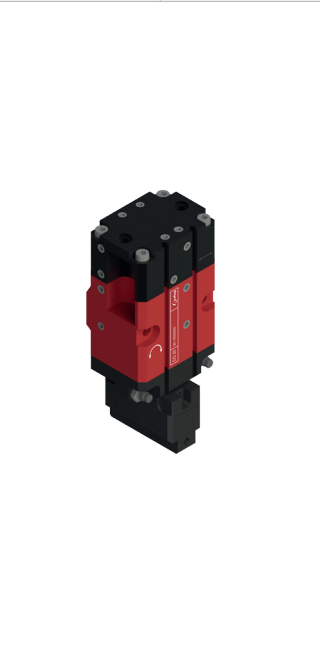

←

→

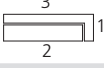
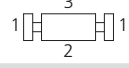
CS 16	1 3	VP 150 < direct >	1,2 1,2
CS 20	1,3	VP 150	1,2
LM 20	1	VP 150	1,2
HM 10	1	VP 150	1,2
HM 16	1	VP 150	1,2
CR 16	3	VP 150	1,2
ES20	1,3	VP 150	1,2
ES30	1,3	VP 150	1,2
ES40	1,3	VP 150	1,2
SA-3	1,2	VP 150	1,2
SA-6	1,2	VP 150	1,2
PEZ-52	3	< direct >	1,2
PEL20	3	VP 150	1
PDL30	3	VP 150	1
PDL40	3	VP 150	1
RE-50	3	VP 150	1
SREH-50	3	direct	1

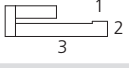

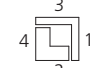
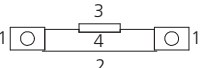
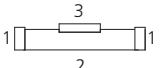
Mounting areas

CS, ES	LM	HM	SA	UG, GM, SG, DG, PG, GE, SGE
				
PMP, PMP-c	PEZ, PDZ	PEL, PDL	RM, RE	CR, RM 32, RE, SREH, RA
				

Note that there might be different mounting positions from one module to another one.
The required connection elements and the range of support columns are depicted in the catalogue HT accessories.

Type	DG 16
Max. static torque Mx	5 Nm
Max. static torque My	5 Nm
Max. static torque Mz	15 Nm
Max. static force Fz	90 N

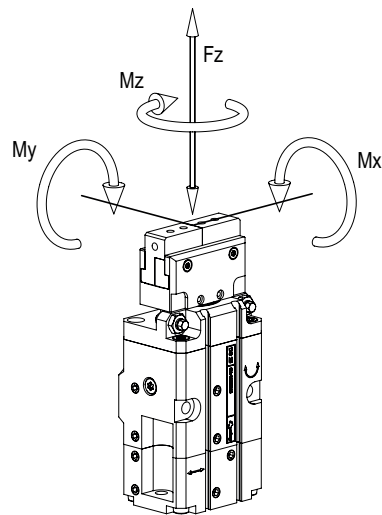

Rotation time diagrams

Rotation time

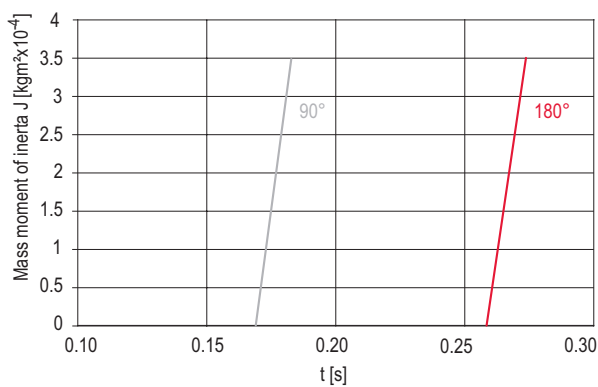

Centric gripping force diagrams, closing/opening

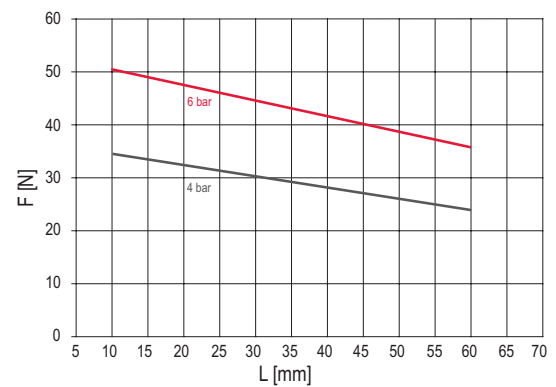

Accessories DG

End stop 90° DG 16

Order number 50307648

Net weight 0.007 kg

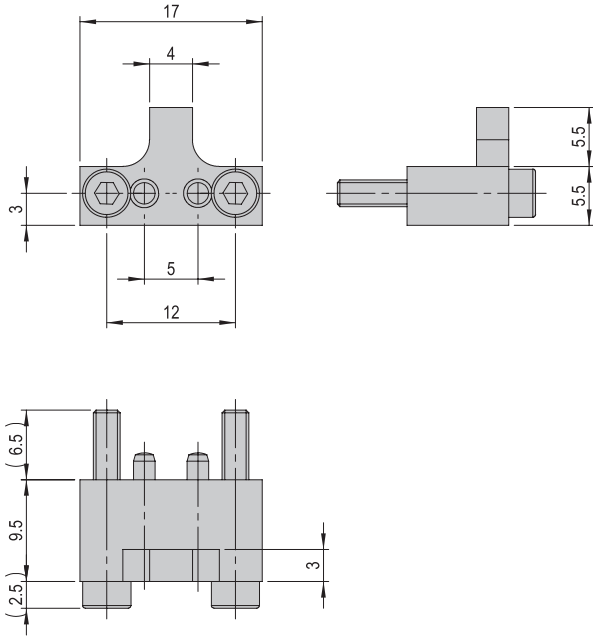

Mounting kit Sensor holder DG 16

Order number 50435052

Gross weight 0.275 kg

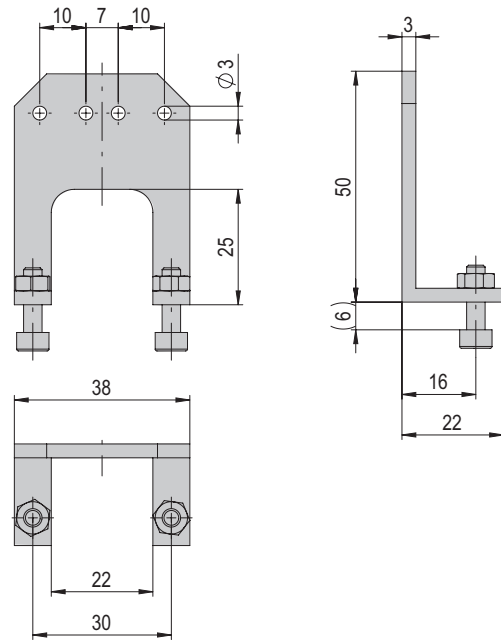

End stop 90° DG 16 (zero position 90°)

Order number 50525638

Gross weight 0.01 kg

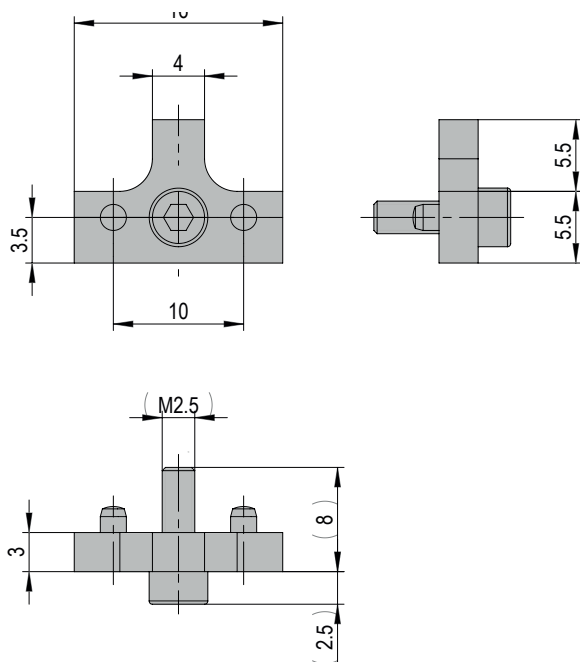

Accessories DG

End stop 90° DG 20

Order number 50433546

Gross weight 0.01 kg

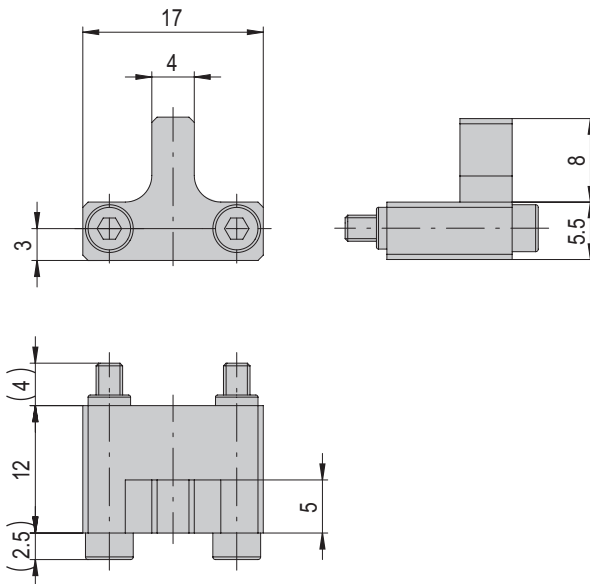

Sensor holder mounting set DG 20

Order number 50451741

Gross weight 0.275 kg

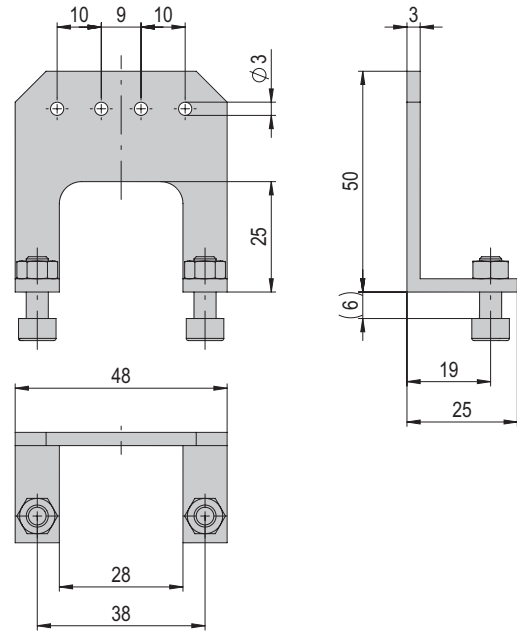

End stop 90° DG 20 (zero position 90°)

Order number 50525639

Gross weight 0.01 kg

