

Portal axes PEL & PDL

PEL20-SL - PEL20 &
PDL30 - PDL40-HP

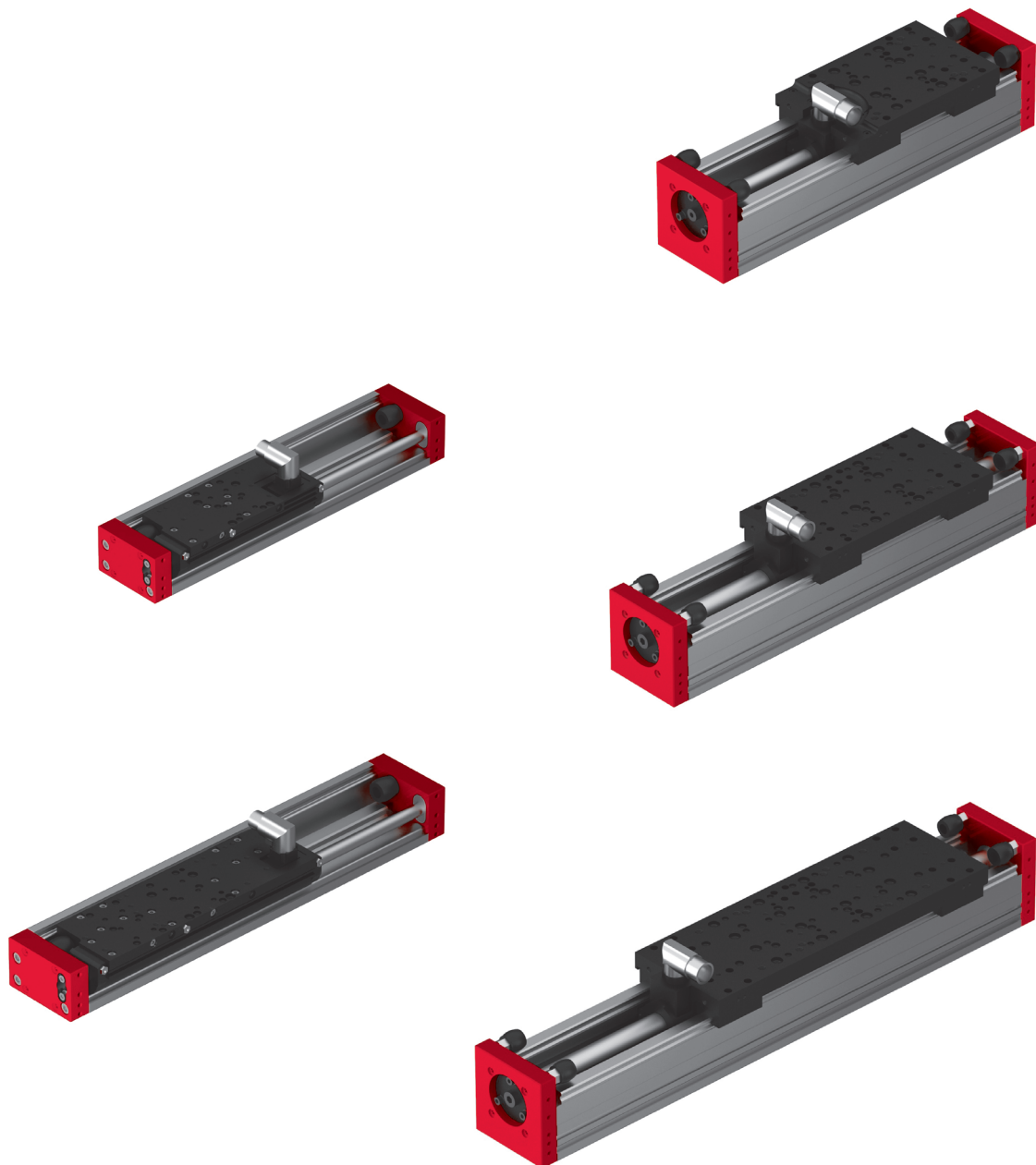
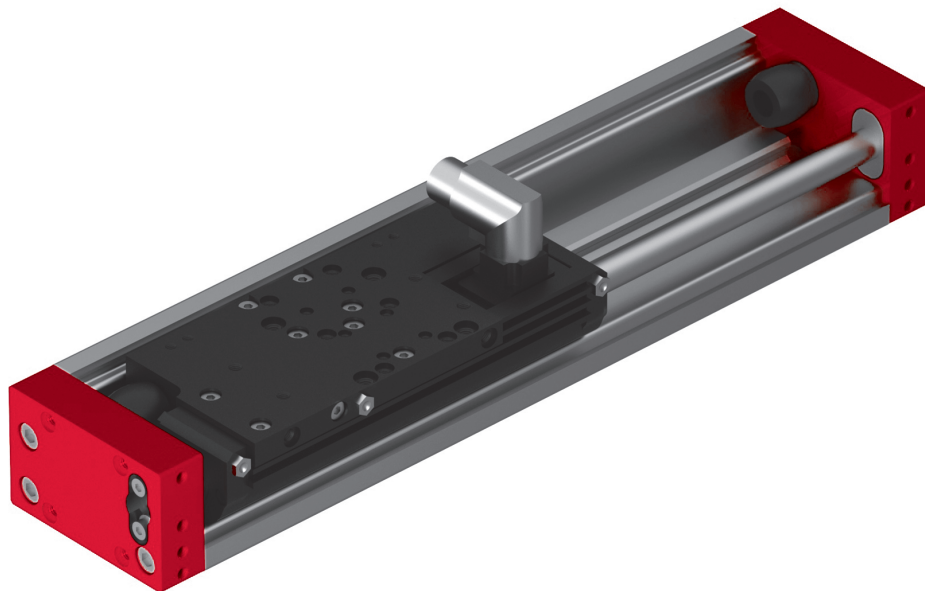

Table of contents: PEL & PDL

Portal axes PEL & PDL	Page
PEL20-SL	327
PEL20	335
PDL30	343
PDL40	351
PDL40-HP	359
Accessories PEL & PDL	366

Portal axes PEL & PDL

PEL20-SL



- Compact, simple portal axis
- Maximum stroke at minimum installation space
- Cost-efficient entry into linear motor technology

Type	PEL20-SL
A	41 mm
L	H + 234 mm

- ① - 270° rotatable connector
- ② - External position measuring system
- ③ - Groove for sliding block size 5

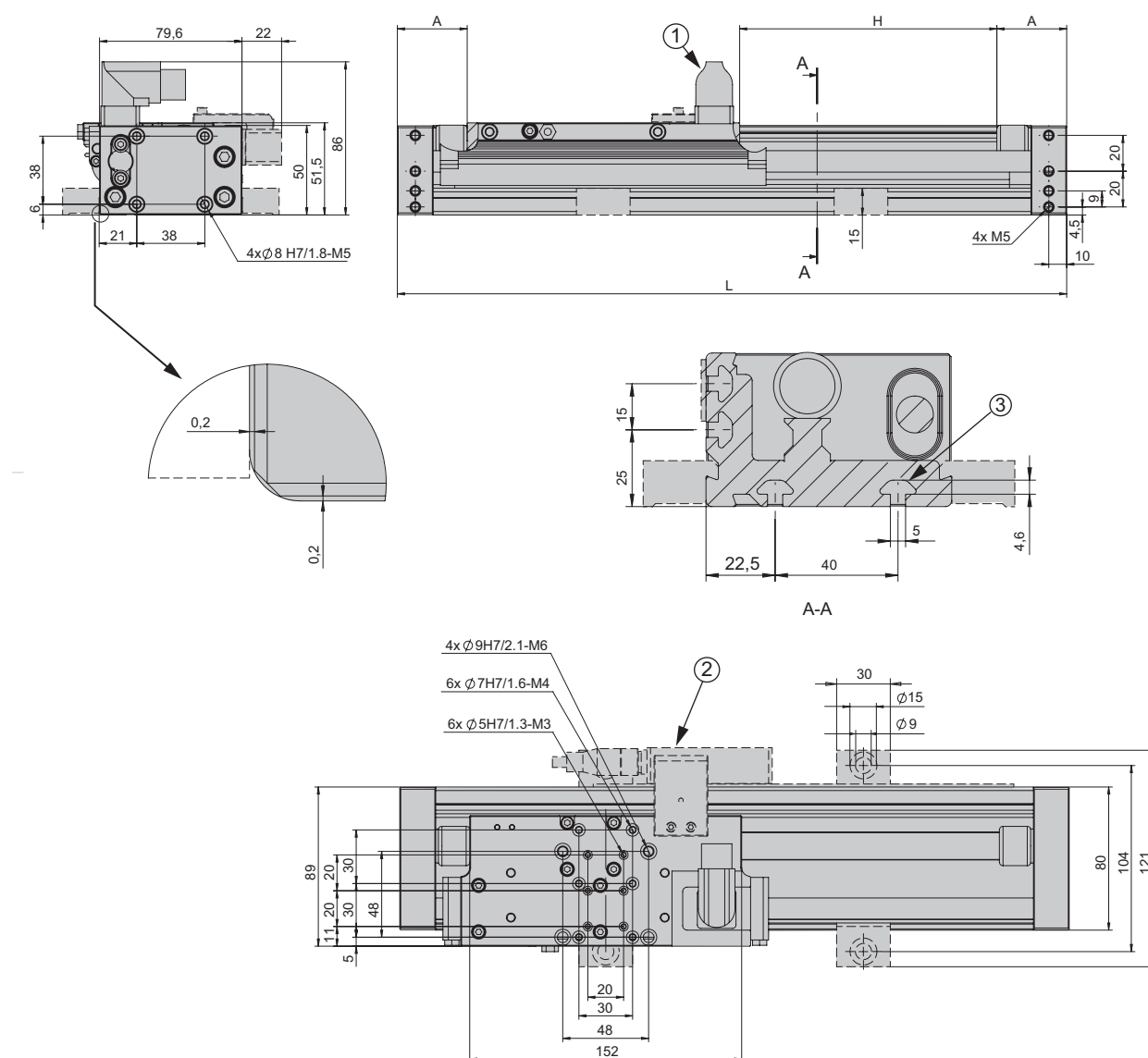

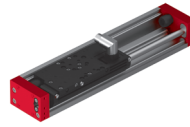

PEL20-SL	
Operating temperature	0 - 50 °C
Storage temperature	0 - 50 °C
Humidity	< 90 %

Type	PEL20-080-SL	PEL20-140-SL	PEL20-210-SL	PEL20-270-SL	PEL20-370-SL	PEL20-550-SL	PEL20-640-SL
Order number	50444484	50444485	50444486	50444487	50444488	50444489	50444490
Stroke H	80 mm	140 mm	210 mm	270 mm	370 mm	550 mm	640 mm
Net weight	3.2 kg	3.5 kg	3.85 kg	4.15 kg	4.65 kg	5.55 kg	6 kg
Max. speed	6.8 m/s						
Moving weight	0.8 kg						
Drive	Linear motor, electric						
Permanent force	15 N						
Peak force	67 N						
Repeat accuracy*	+/- 0.05 mm						
- with external position measuring system	+/- 0.02 mm						
Mounting position							

The technical data pertains to Afag standard test conditions.
 Note: For vertical installation, a weight compensation is required.
 Cleanroom class ISO 14644-1, class ISO 7

*The installation of the portal axis, via attachment blocks, guarantees improved rigidity and accuracy.

Included in the delivery

(Catalogue HT accessories)

- 4x Centering bushing Ø8x3.5
- Funnel-type lubrication nipple 90° M6

Accessories

▪ External position measuring system PEL20 [p. 365]

- Connecting set VS 516 [p. 366]

(Catalogue HT accessories)

- T-nut M5
- Motor cable-M16
- Controller C11xx-1S
- Plug kit for C1xxx-1S
- USB-RS232 Converter for controllers
- Power supply S01-72/500, 1-phase

Alternative Accessories

(Catalogue HT accessories)

- Additional motor cables
- Additional controllers
- Additional power supplies
- Console in program for supports/columns
- Drag-chain on request

Warranty: 24 months following commissioning, but a maximum of 27 months following delivery

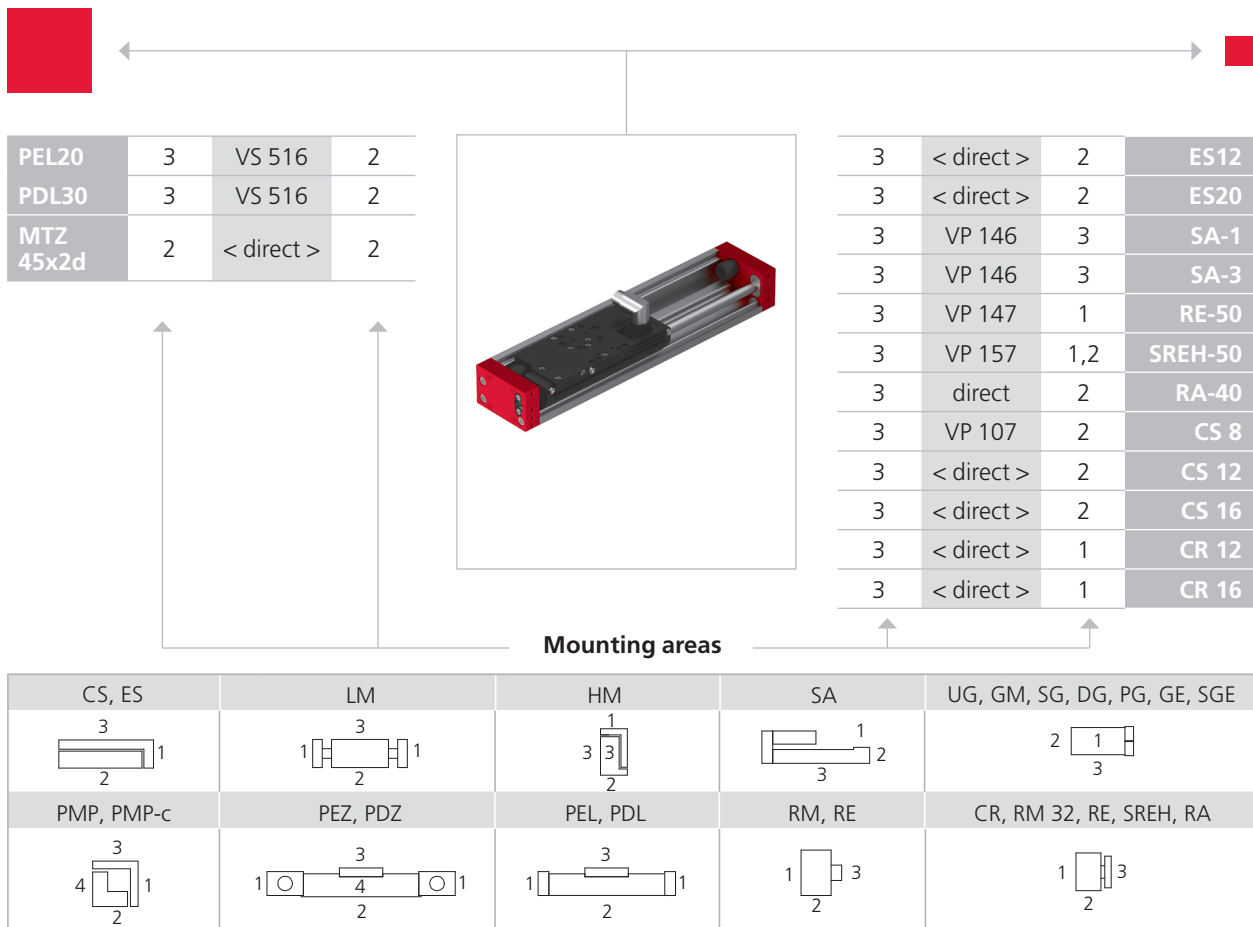

Note that there might be different mounting positions from one module to another one.

The required connection elements and the range of support columns are depicted in the catalogue HT accessories.

Type	PEL20-SL
Force F_y	1500 N
Force F_z	1500 N
Max. dynamic torque M_x	50 Nm
Max. dynamic torque M_y	40 Nm
Max. dynamic torque M_z	40 Nm

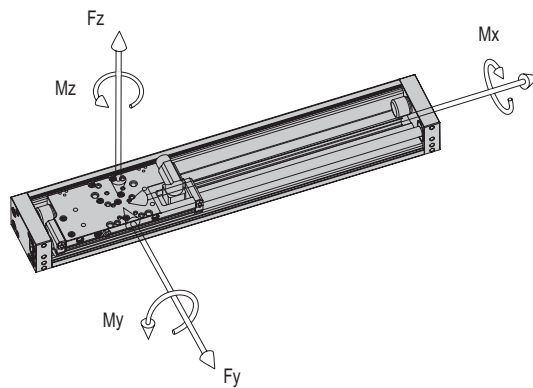

Maximum payload/type	PEL20-SL
Installation position (horizontal) for mounting side 3	5 kg
Installation position (vertical) for mounting side 3	5 kg

Assembly sides module mounting

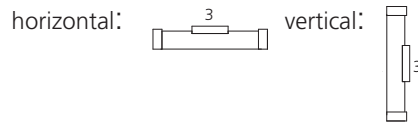

Operation time diagram

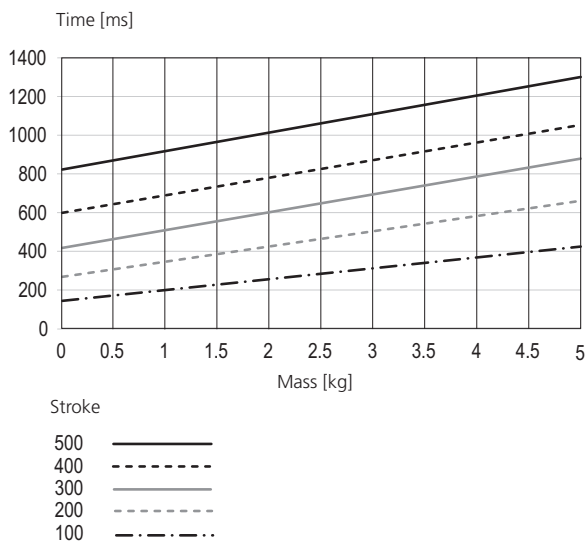

Running times based on pause times of 300 ms

Order form	PEL20-SL	XXXXXXXX	XX XXXXXXXX	XXXXXXXX	XXXXXXXX
		Portal axis	External position measuring system	Additional slides short (SL)	Additional slides long

Coordinate system

The coordinate system allows you to define the position of the external position measuring system.

- VL = front left
- HL = back left

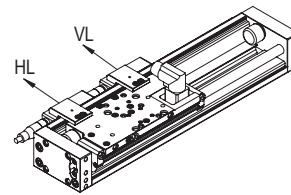

Ordering example 1 without external position measuring system and without additional slide

PEL20-SL	50444488	x	x	x
----------	----------	---	---	---

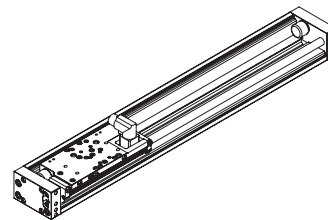

Ordering example 2 with external position measuring system and with additional slide long

PEL20-SL	50444490	HL 50472112	x	16620359
----------	----------	-------------	---	----------

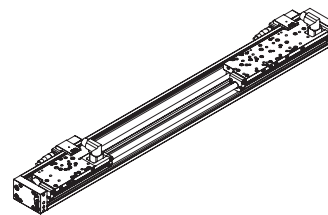

Ordering process

- Select the desired portal axis from the order key.
- Enter the corresponding red order numbers in the order form in the place of the cross.
- If an external position measuring system is desired, fill-in the corresponding letters from the coordinate system for the location and the order number.
- If additional slides are needed, fill-in the respective order number several times correspondingly.

Additional slides

- The additional slide is always positioned to right of the current slide of the portal axis.

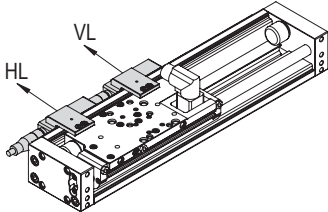
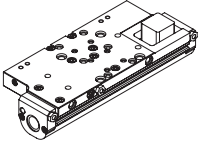
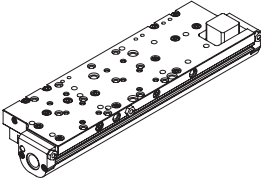
Portal axis	PEL20-SL	xxxxxxx	xx xxxxxxx	xxxxxxx	xxxxxxx
	PEL20-80-SL	50444484	External position measuring system	Additional slide (SL)	Additional slide long
	PEL20-140-SL	50444485			
	PEL20-210-SL	50444486			
	PEL20-270-SL	50444487			
	PEL20-370-SL	50444488			
	PEL20-550-SL	50444489			
	PEL20-640-SL	50444490			
External position measuring system					
	Without				X
	Front Left			VL 50472112	
	Back Left			HL 50472112	
Additional slide	Quantity short (SL)				16620309 Additional slide PEL20-SL with wiper
	Quantity long				16620359 Additional slide PEL20 with wiper

The entire stroke of the portal axis is reduced by 155 mm for a short additional slide (SL), and by 235 mm for a long one.

Portal axes PEL & PDL

PEL20

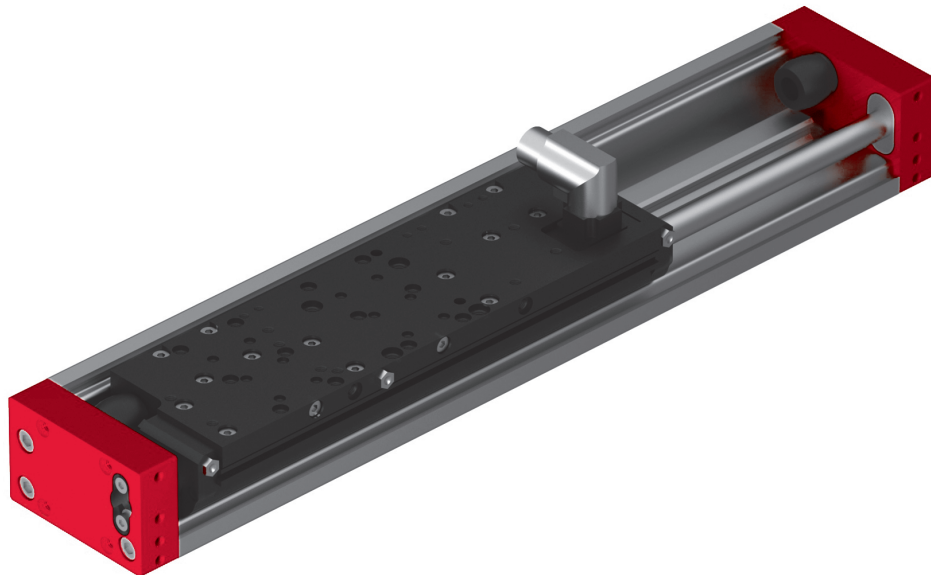

- Compact axis for higher masses
- High flexibility from comprehensive drilling pattern
- Long service life from direct drive

Type	PEL20
A	41 mm
L	H + 314 mm

- ① - 270° rotatable connector
- ② - External position measuring system
- ③ - Groove for sliding block size 5

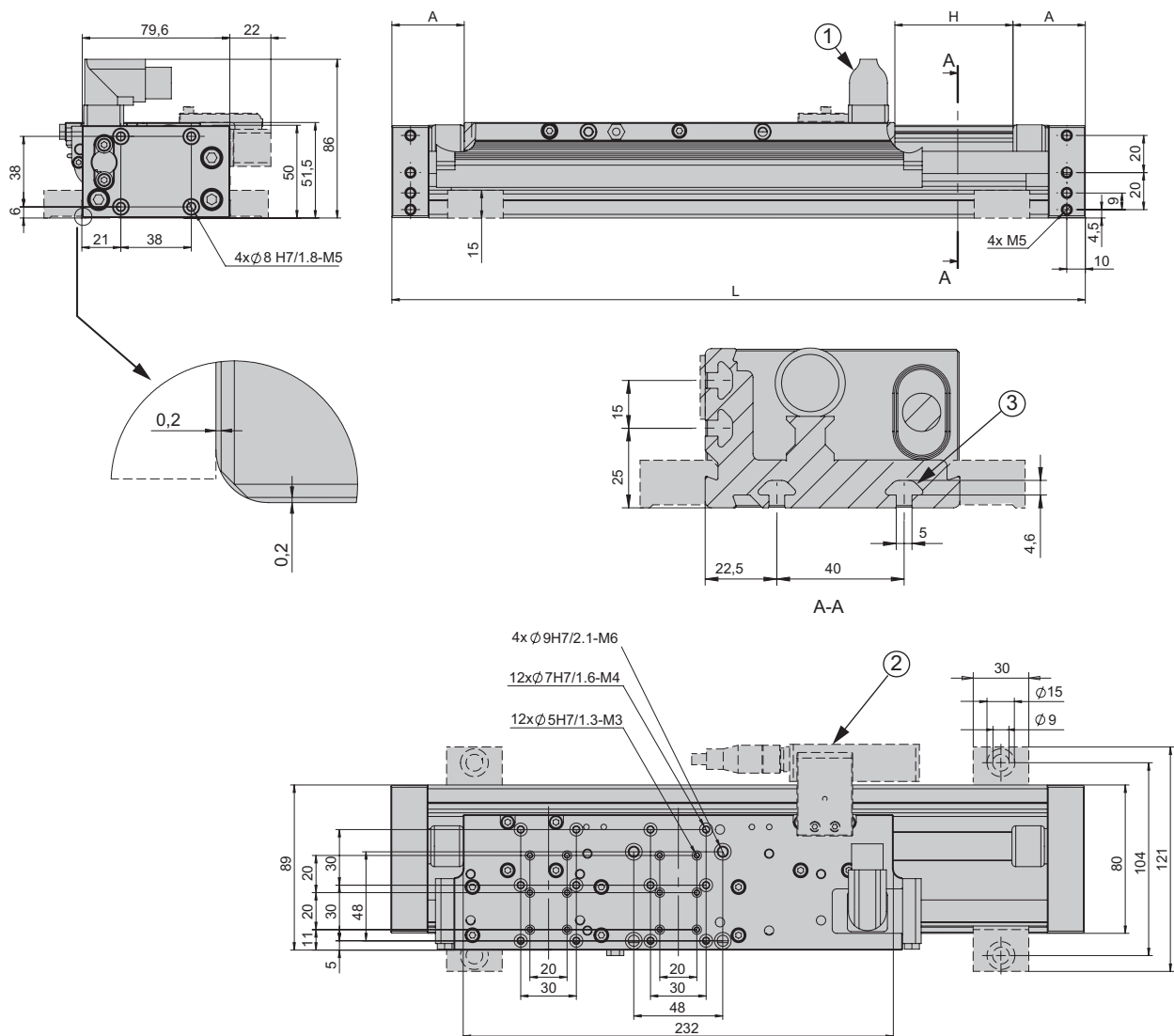

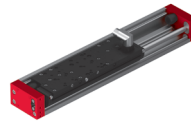

PEL20	
Operating temperature	0 - 50 °C
Storage temperature	0 - 50 °C
Humidity	< 90 %

Type	PEL20-060	PEL20-130	PEL20-190	PEL20-290	PEL20-470	PEL20-560
Order number	50444491	50444492	50444493	50444494	50444495	50444496
Stroke H	60 mm	130 mm	190 mm	290 mm	470 mm	560 mm
Net weight	3.3 kg	3.65 kg	3.95 kg	4.45 kg	5.35 kg	5.8 kg
Max. speed	4.8 m/s					
Moving weight	1.2 kg					
Drive	Linear motor, electric					
Permanent force	31 N					
Peak force	137 N					
Repeat accuracy*	+/- 0.05 mm					
- with external position measuring system	+/- 0.02 mm					
Mounting position	✦					

The technical data pertains to Afag standard test conditions.
 Note: For vertical installation, a weight compensation is required.
 Cleanroom class ISO 14644-1, class ISO 7

*The installation of the portal axis, via attachment blocks, guarantees improved rigidity and accuracy.

Included in the delivery

(Catalogue HT accessories)

- 4x Centering bushing Ø8x3.5
- Funnel-type lubrication nipple 90° M6

Accessories

- External position measuring system PEL20 [p. 365]
 - Connecting set VS 516 [p. 366]
- (Catalogue HT accessories)
- T-nut M5
 - Motor cable-M16
 - Controller C11xx-1S
 - Plug kit for C1xxx-1S
 - USB-RS232 Converter for controllers
 - Power supply S01-72/500, 1-phase

Alternative Accessories

- (Catalogue HT accessories)
- Additional motor cables
 - Additional controllers
 - Additional power supplies
 - Console in program for supports/columns
 - Drag-chain on request

Warranty: 24 months following commissioning, but a maximum of 27 months following delivery

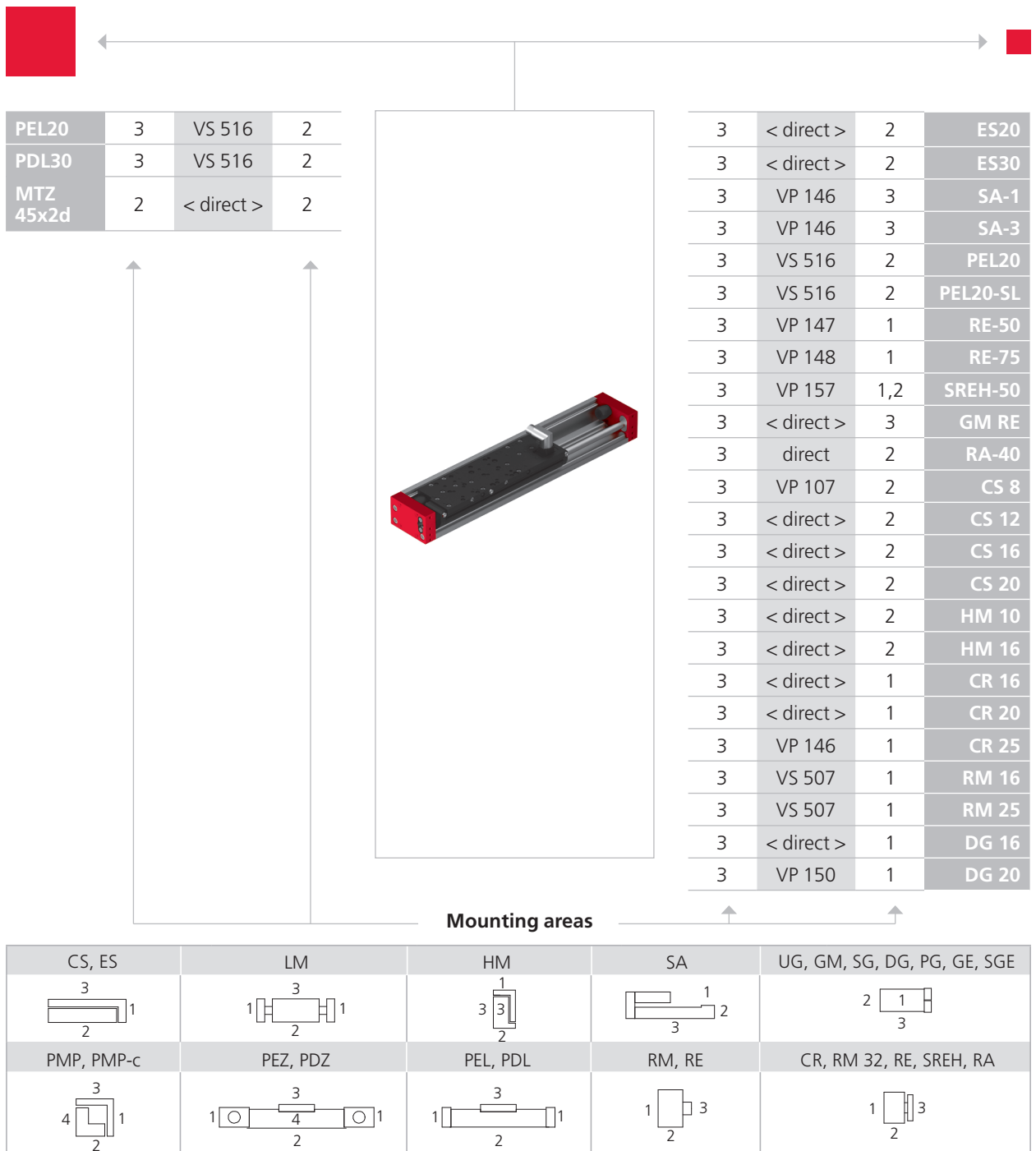

Note that there might be different mounting positions from one module to another one.
 The required connection elements and the range of support columns are depicted in the catalogue HT accessories.

Type	PEL20
Force F_y	3000 N
Force F_z	3000 N
Max. dynamic torque M_x	80 Nm
Max. dynamic torque M_y	300 Nm
Max. dynamic torque M_z	300 Nm

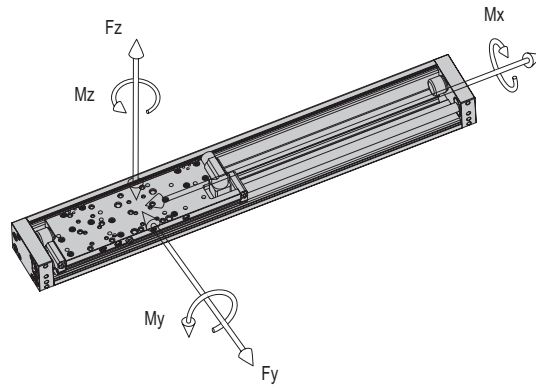

Maximum payload/type	PEL20
Installation position (horizontal) for mounting side 3	10 kg
Installation position (vertical) for mounting side 3	10 kg

Assembly sides module mounting

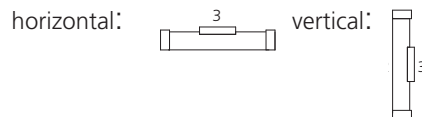

Operation time diagram

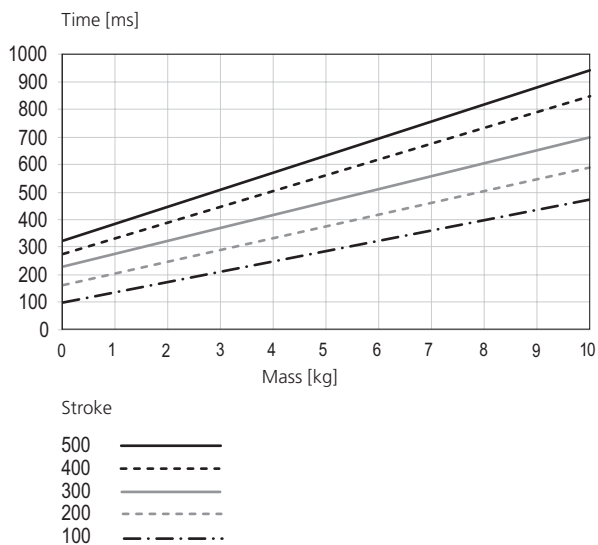

Running times based on pause times of 300 ms

Order form	PEL20	XXXXXXXX	XX XXXXXXXX	XXXXXXXX	XXXXXXXX
		Portal axis	External position measuring system	Additional slides short (SL)	Additional slides long

Coordinate system

The coordinate system allows you to define the position of the external position measuring system.

- HL = back left
- ML = middle left
- VL = front left

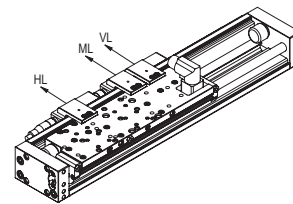

Ordering example 1 with external position measuring system and without additional slide

PEL20	50444494	ML 50472112	x	x
-------	----------	-------------	---	---

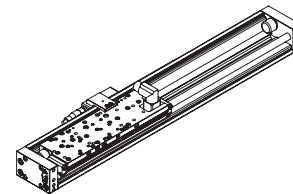

Ordering example 2 without external position measuring system and with additional slide (long)

PEL20	50444496	x	x	16620359
-------	----------	---	---	----------

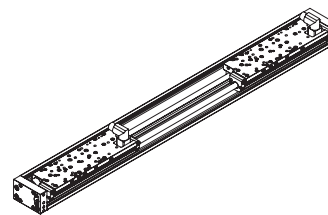

Ordering process

- Select the desired portal axis from the order key.
- Enter the corresponding red order numbers in the order form in the place of the cross.
- If an external position measuring system is desired, fill-in the corresponding letters from the coordinate system for the location and the order number.
- If additional slides are needed, fill-in the respective order number several times correspondingly.

Additional slides

- The additional slide is always positioned to right of the current slide of the portal axis.

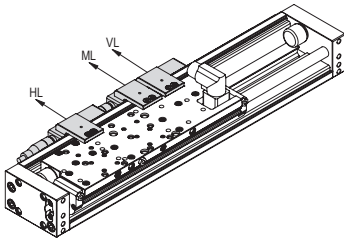
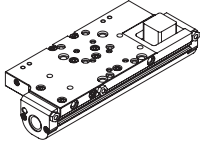
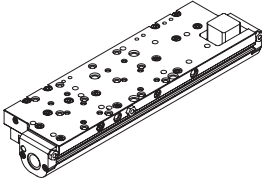
Portal axis	PEL20	XXXXXXXX	XX XXXXXXXX	XXXXXXXX	XXXXXXXX
	PEL20-60	50444491	External position measuring system	Additional slide (SL)	Additional slide long
	PEL20-130	50444492			
	PEL20-190	50444493			
	PEL20-290	50444494			
	PEL20-470	50444495			
	PEL20-560	50444496			
External position measuring system					
	Without		X		
	Front Left		VL 50472112		
	Middle Left		ML 50472112		
Back Left		HL 50472112			
Additional slide	Quantity short (SL)			16620309 Additional slide PEL20-SL with wiper	
	Quantity long			16620359 Additional slide PEL20 with wiper	

The entire stroke of the portal axis is reduced by 155 mm for a short additional slide (SL), and by 235 mm for a long one.

Portal axes PEL & PDL

PDL30

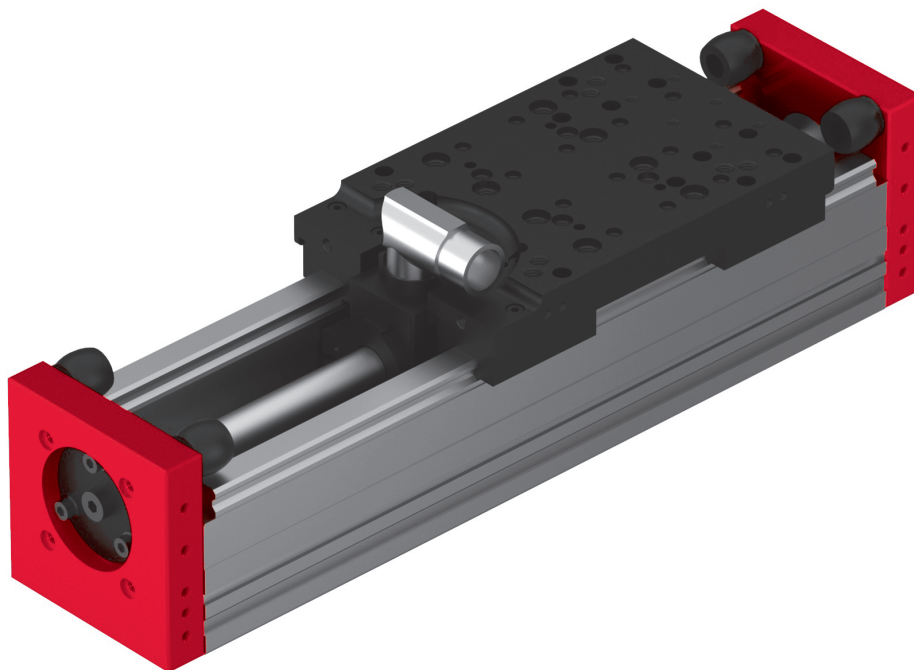

- High torsion stiffness from double guide
- Ideal for area booms
- Robust design for long service life

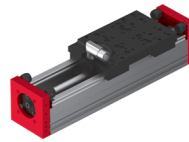

PDL30	
Operating temperature	0 - 50 °C
Storage temperature	0 - 50 °C
Humidity	< 90 %

Type	PDL30-0090-D19	PDL30-0150-D19	PDL30-0250-D19	PDL30-0350-D19	PDL30-0450-D19	PDL30-0550-D19	PDL30-0650-D19
Order number	50444497	50444498	50444499	50444500	50444501	50444502	50444503
Stroke H	90 mm	150 mm	250 mm	350 mm	450 mm	550 mm	650 mm
Net weight	7.2 kg	7.8 kg	8.8 kg	9.8 kg	10.8 kg	11.8 kg	12.8 kg
Max. speed	3.2 m/s						
Moving weight	3.11 kg						
Drive	Linear motor, electric						
Permanent force	51 N						
Peak force	255 N						
Repeat accuracy	+/- 0.05 mm						
- with external position measuring system	+/- 0.05 mm						

Type	PDL30-0130-D20	PDL30-0230-D20	PDL30-0330-D20	PDL30-0430-D20	PDL30-0530-D20	PDL30-0630-D20	PDL30-0730-D20
Order number	50444504	50444505	50444506	50444507	50444508	50444509	50444510
Stroke H	130 mm	230 mm	330 mm	430 mm	530 mm	630 mm	730 mm
Net weight	7.6 kg	8.6 kg	9.6 kg	10.6 kg	11.6 kg	12.6 kg	13.6 kg
Max. speed	3.2 m/s						
Moving weight	3.11 kg						
Drive	Linear motor, electric						
Permanent force	51 N						
Peak force	255 N						
Repeat accuracy	+/- 0.05 mm						
- with external position measuring system	+/- 0.02 mm						

Type	PDL30-0930-D20	PDL30-1130-D20	PDL30-1330-D20
Order number	50444511	50444512	50444513
Stroke H	930 mm	1130 mm	1330 mm
Net weight	15.6 kg	17.6 kg	19.6 kg
Max. speed	3.2 m/s		
Moving weight	3.11 kg		
Drive	Linear motor, electric		
Permanent force	51 N		
Peak force	255 N		
Repeat accuracy	+/- 0.05 mm		
- with external position measuring system	+/- 0.02 mm		
Mounting position is the same for all PDL30			

The technical data pertains to Afag standard test conditions.
 Note: For vertical installation, a weight compensation is required.
 Cleanroom class ISO 14644-1, class ISO 7

Included in the delivery

(Catalogue HT accessories)

- 4x Centering bushing Ø9x4

Accessories

- External position measuring system PDL30/40 [p. 365]
 - Connecting set VS 516 [p. 366]
- (Catalogue HT accessories)
- T-nut M8
 - Motor cable-M17
 - Controller C11xx-1S
 - Plug kit for C1xxx-1S
 - USB-RS232 Converter for controllers
 - Power supply S01-72/1000, 3-phase

Alternative Accessories

(Catalogue HT accessories)

- Additional motor cables
- Additional controllers
- Additional power supplies
- Console in program for supports/columns
- Drag-chain on request

Warranty: 24 months following commissioning, but a maximum of 27 months following delivery

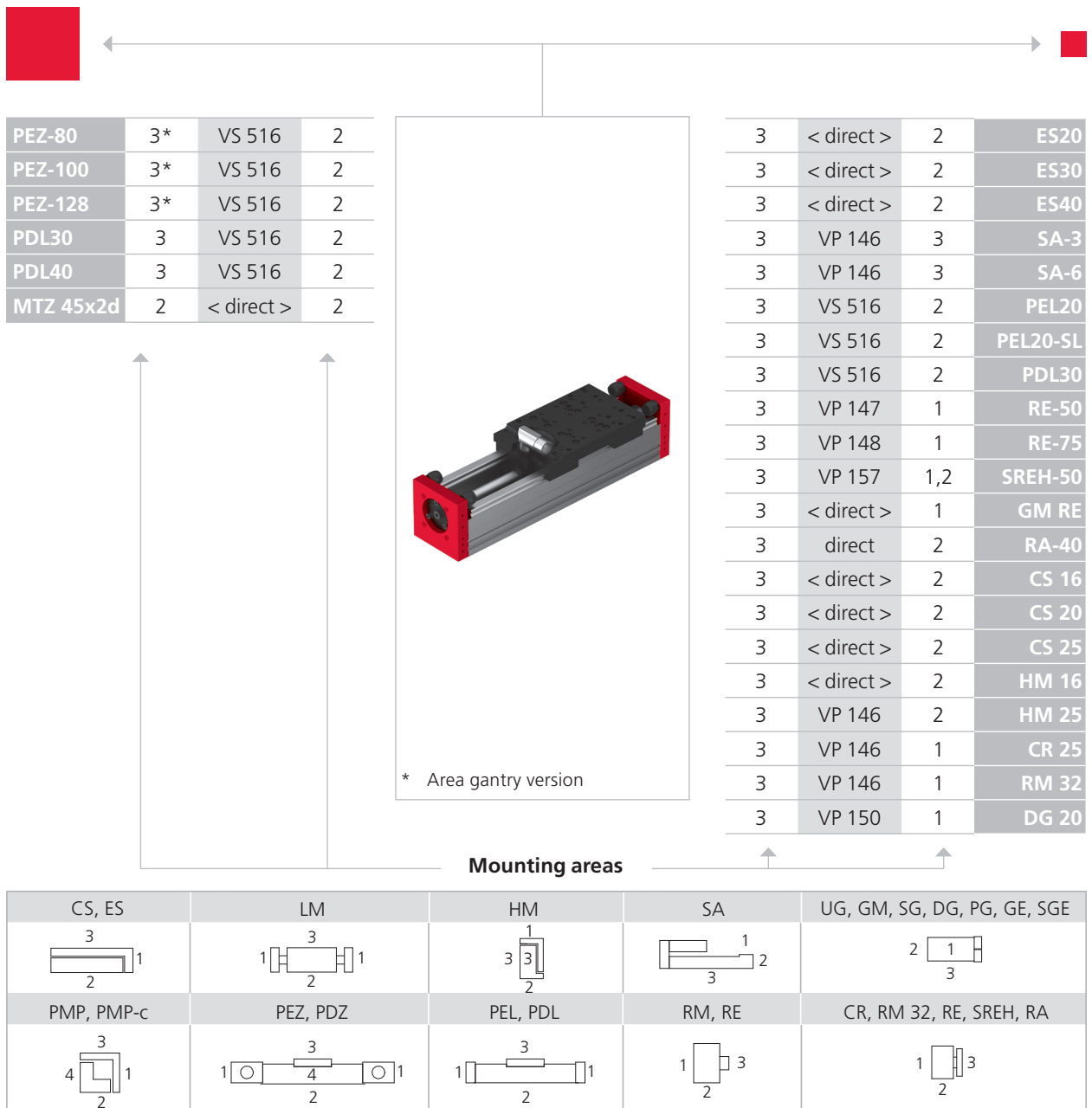

Note that there might be different mounting positions from one module to another one.
The required connection elements and the range of support columns are depicted in the catalogue HT accessories.

Type	PDL30
Force F_y	4500 N
Force F_z	4500 N
Max. dynamic torque M_x	850 Nm
Max. dynamic torque M_y	1400 Nm
Max. dynamic torque M_z	1400 Nm

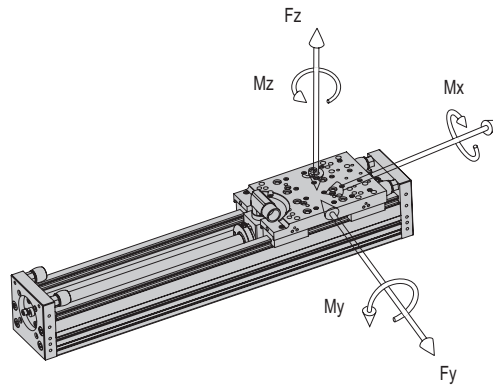

Maximum payload/type	PDL30
Installation position (horizontal) for mounting side 3	20 kg
Installation position (vertical) for mounting side 3	20 kg

Assembly sides module mounting

horizontal:

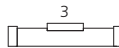

vertical:



Diagram PDL30

Force range D19

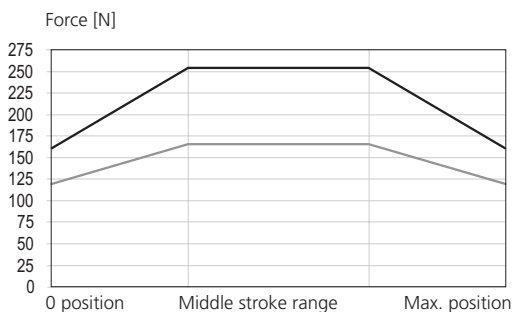

Middle stroke range	Controller HC (15 A)	Controller Std (8 A)
PDL30-90-D19	20 mm	—
PDL30-150-D19	80 mm	—
PDL30-250-D19	180 mm	—
PDL30-350-D19	280 mm	—
PDL30-450-D19	380 mm	—
PDL30-550-D19	480 mm	—
PDL30-650-D19	580 mm	—

Operation time diagram

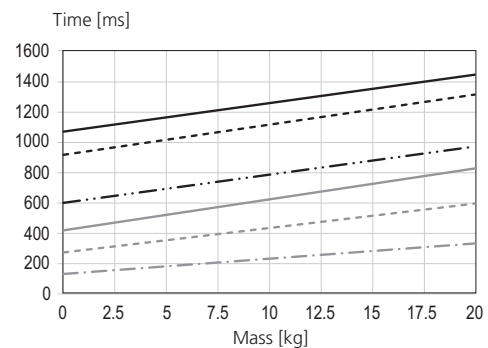

Running times based on pause times of 200 ms

Order form	PDL30	XXXXXXXX	XX XXXXXXXX	XXXXXXXX
		Portal axis	External position measuring system	Additional slides

Coordinate system

The coordinate system allows you to define the position of the external position measuring system.

- VR= front right
- HR= back right
- VL= front left
- HL= back left

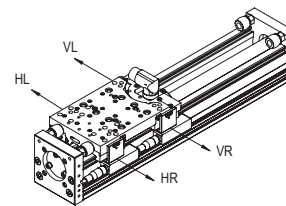

Ordering example 1 with external position measuring system and without additional slide

PDL30	50444499	VR 50472113	x
-------	----------	-------------	---

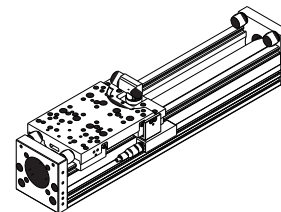

Ordering example 2 with external position measuring system and with additional slide

PDL30	50444512	HL 50472113	16630159
-------	----------	-------------	----------

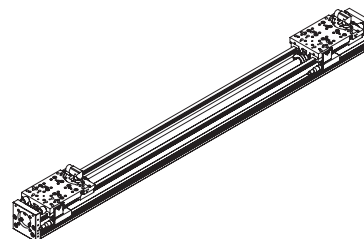

Ordering process

- Select the desired portal axis from the order key.
- Enter the corresponding red order numbers in the order form in the place of the cross.
- If an external position measuring system is desired, fill-in the corresponding letters from the coordinate system for the location and the order number.
- If additional slides are needed, fill-in the respective order number several times correspondingly.

Additional slides

- The additional slide is always positioned to right of the current slide of the portal axis.

Portal axis	PDL30	xxxxxxx	xx xxxxxxxx	xxxxxxx
	PDL30-90-D19	50444497	External position measuring system	Additional slide
	PDL30-150-D19	50444498		
	PDL30-250-D19	50444499		
	PDL30-350-D19	50444500		
	PDL30-450-D19	50444501		
	PDL30-550-D19	50444502		
	PDL30-650-D19	50444503		
	PDL30-130-D20	50444504		
	PDL30-230-D20	50444505		
	PDL30-330-D20	50444506		
	PDL30-430-D20	50444507		
	PDL30-530-D20	50444508		
	PDL30-630-D20	50444509		
	PDL30-730-D20	50444510		
	PDL30-930-D20	50444511		
	PDL30-1130-D20	50444512		
PDL30-1330-D20	50444513			
External position measuring system	Without		X	
	Front right		VR 50472113	
	Back right		HR 50472113	
	Front left		VL 50472113	
	Back left		HL 50472113	
Additional slide	Additional slide			166316630159 Additional slide PDL30 with wiper
				16630160 Additional slide PDL30 withpout wiper for slider D19

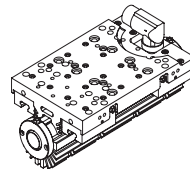
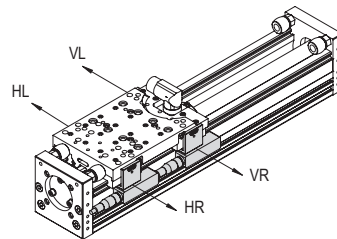

The entire stroke of the portal axis is reduced by 228 mm for an additional slide with a D19 portal axis and by 247 mm with a D20 portal axis.

Additional slide without wiper for high-clearance slider D19 only.

Portal axes PEL & PDL

PDL40

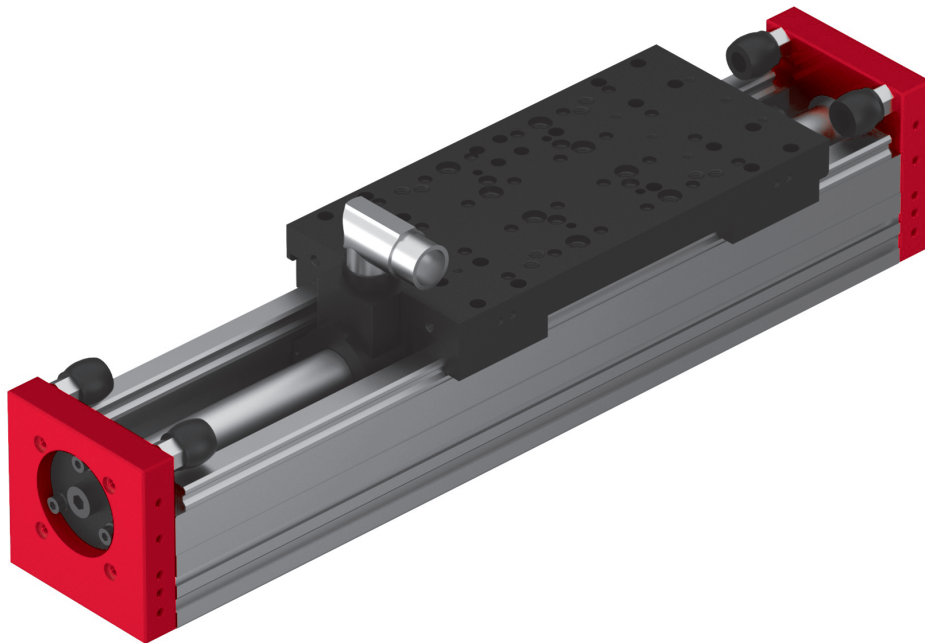

- Force package with high dynamics
- For the faster applications
- High performance from compact build

Dimensions and dimension drawings

PDL40

Type	PDL40-D27	PDL40-D28
A	49 mm	64 mm
L	H + 340 mm	H + 370 mm

- ① - 270° rotatable connector
- ② - External position measuring system
- ③ - Groove for sliding block size 8
- ④ - Groove for sliding block size 5

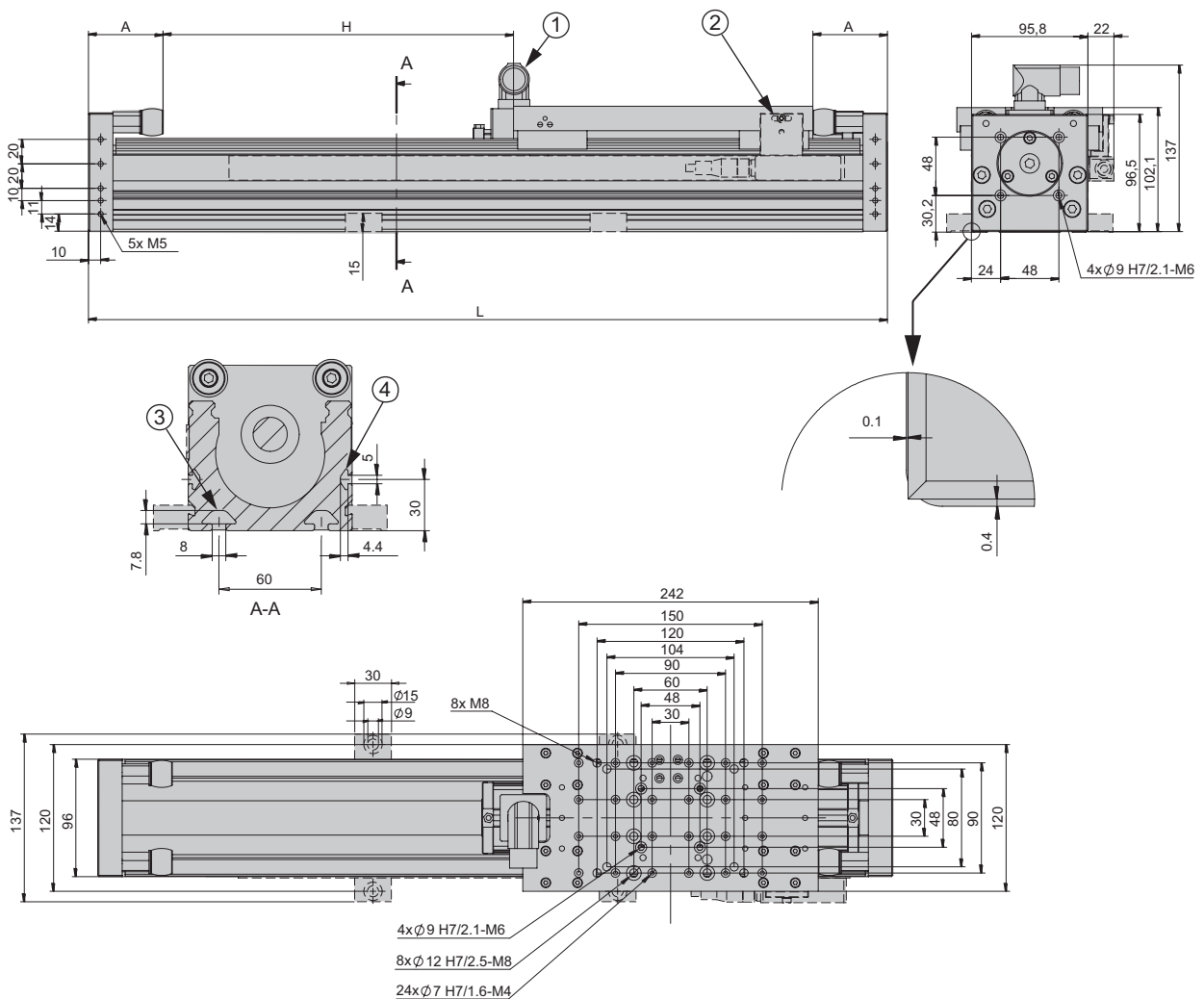

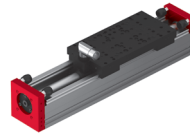

PDL40	
Operating temperature	0 - 50 °C
Storage temperature	0 - 50 °C
Humidity	< 90 %

Type	PDL40-0170-D27	PDL40-0230-D27	PDL40-0320-D27	PDL40-0440-D27	PDL40-0530-D27
Order number	50444514	50444515	50444516	50444517	50444518
Stroke H	170 mm	230 mm	320 mm	440 mm	530 mm
Net weight	10.2 kg	10.8 kg	11.7 kg	12.9 kg	13.8 kg
Max. speed	3 m/s				
Moving weight	4.64 kg				
Drive	Linear motor, electric				
Permanent force	145 N				
Peak force	550 N				
Repeat accuracy	+/- 0.05 mm				
- with external position measuring system	+/- 0.02 mm				

Type	PDL40-0070-D28	PDL40-0160-D28	PDL40-0280-D28	PDL40-0370-D28	PDL40-0460-D28	PDL40-0580-D28	PDL40-0670-D28
Order number	50444519	50444520	50444521	50444522	50444523	50444524	50444525
Stroke H	70 mm	160 mm	280 mm	370 mm	460 mm	580 mm	670 mm
Net weight	9.2 kg	10.1 kg	11.3 kg	12.2 kg	13.1 kg	14.3 kg	15.2 kg
Max. speed	3 m/s						
Moving weight	4.64 kg						
Drive	Linear motor, electric						
Permanent force	145 N						
Peak force	550 N						
Repeat accuracy	+/- 0.05 mm						
- with external position measuring system	+/- 0.02 mm						

Type	PDL40-0880-D28	PDL40-1060-D28	PDL40-1270-D28	PDL40-1480-D28	PDL40-1660-D28
Order number	50444526	50444527	50444528	50444529	50444530
Stroke H	880 mm	1060 mm	1270 mm	1480 mm	1660 mm
Net weight	17.3 kg	19.1 kg	21.2 kg	23.3 kg	25.1 kg
Max. speed	3 m/s				
Moving weight	4.64 kg				
Drive	Linear motor, electric				
Permanent force	145 N				
Peak force	550 N				
Repeat accuracy	+/- 0.05 mm				
- with external position measuring system	+/- 0.02 mm				
Mounting position is the same for all PDL40	✦				

The technical data pertains to Afag standard test conditions. Note: For vertical installation, a weight compensation is required. Cleanroom class ISO 14644-1, class ISO 7

Included in the delivery

(Catalogue HT accessories)

- 4x Centering bushing Ø9x4

Accessories

- External position measuring system PDL30/40 [p. 365]

- Connecting set VS 516 [p. 366]

(Catalogue HT accessories)

- T-nut M8
- Motor cable-M17
- Controller C11xx-1S
- Plug kit for C1xxx-1S
- USB-RS232 Converter for controllers
- Power supply S01-72/1000, 3-phase

Alternative accessories

(Catalogue HT accessories)

- Additional motor cables
- Additional controllers
- Additional power supplies
- Console in program for supports/columns
- Drag-chain on request

Warranty: 24 months following commissioning, but a maximum of 27 months following delivery

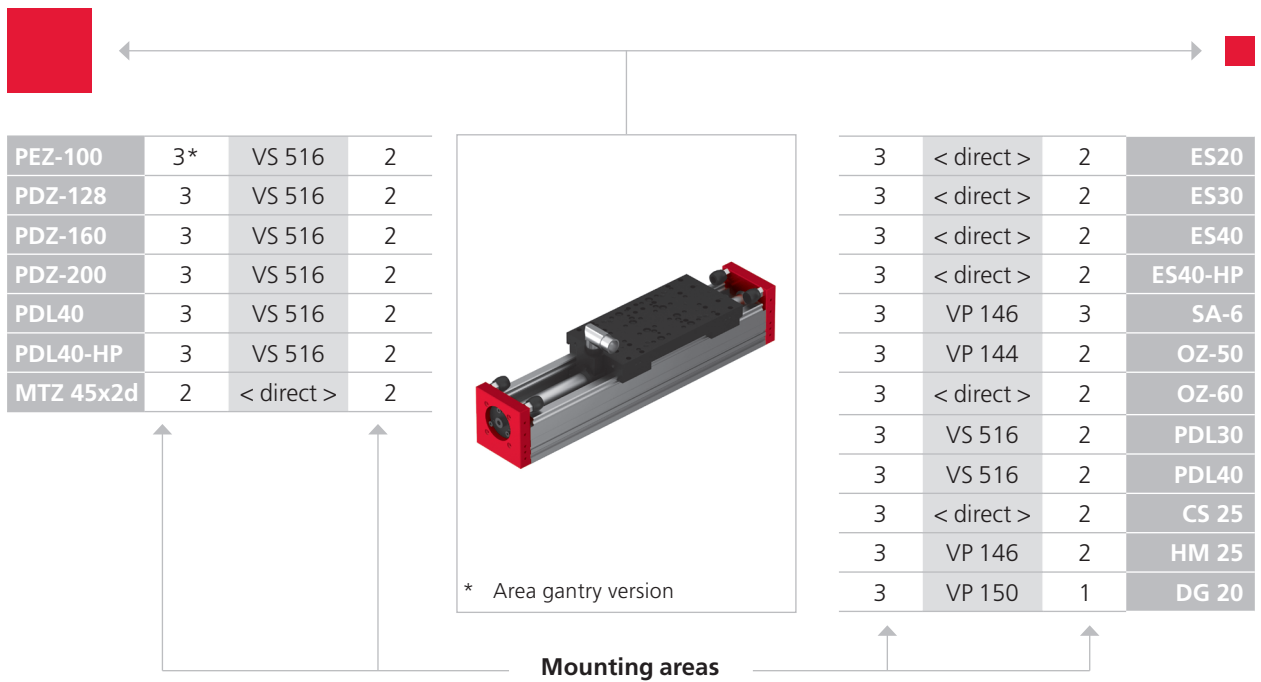

CS, ES	LM	HM	SA	UG, GM, SG, DG, PG, GE, SGE
PMP, PMP-c	PEZ, PDZ	PEL, PDL	RM, RE	CR, RM 32, RE, SREH, RA

Note that there might be different mounting positions from one module to another one.
 The required connection elements and the range of support columns are depicted in the catalogue HT accessories.

Type	PDL40
Force F_y	4500 N
Force F_z	4500 N
Max. dynamic torque M_x	850 Nm
Max. dynamic torque M_y	1900 Nm
Max. dynamic torque M_z	1900 Nm

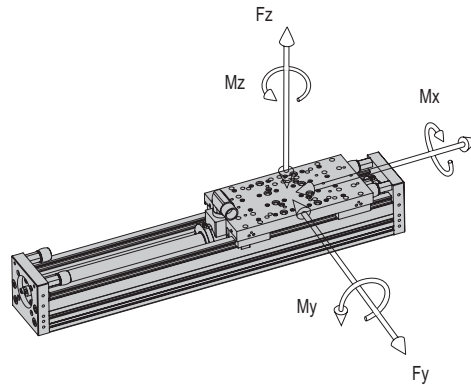

Maximum payload/type	PDL40
Installation position (horizontal) for mounting side 3	45 kg
Installation position (vertical) for mounting side 3	45 kg

Assembly sides module mounting

horizontal:

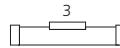

vertical:



PDL40 diagrams

Force range D27

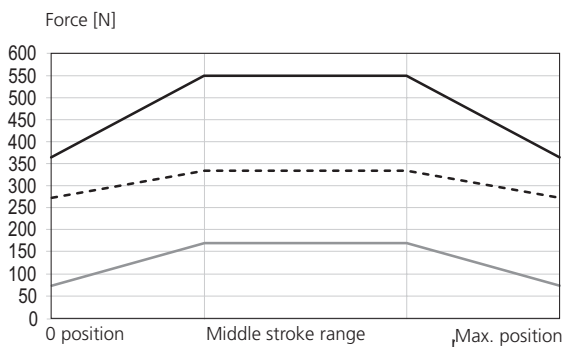

- | | | | |
|---------------------|--------|----------------------|-----------|
| Middle stroke range | | Controller XC (25 A) | ————— |
| PDL40-170-D27 | 30 mm | Controller HC (15 A) | - - - - - |
| PDL40-230-D27 | 90 mm | Controller Std (8 A) | ————— |
| PDL40-320-D27 | 180 mm | | |
| PDL40-440-D27 | 300 mm | | |
| PDL40-530-D27 | 390 mm | | |

Opt. Time [ms] me diagram

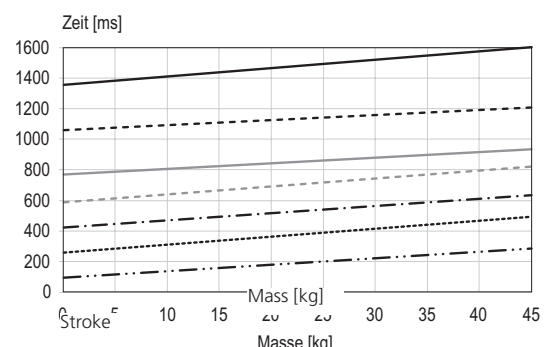

- | | |
|------|-----------|
| Hub | |
| 1600 | ————— |
| 1200 | - - - - - |
| 900 | ————— |
| 700 | - - - - - |
| 500 | - |
| 300 | - - - - - |
| 100 | - |

Running times based on pause times of 200 ms

Order form	PDL40	XXXXXXXX	XX XXXXXXXX	XXXXXXXX	XXXXXXXX
		Portal axis	External position measuring system	Clamping element	Additional slides

Coordinate system

The coordinate system allows you to define the position of the external position measuring system.

- VR= front right
- HR= back right
- VL= front left
- HL= back left

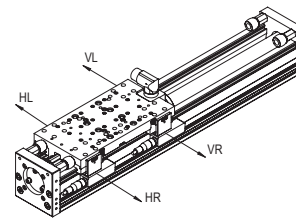

Ordering example 1 with external position measuring system, clamping element and without additional slide

PDL40	50444518	VR 50472113	16640324	x
-------	----------	-------------	----------	---

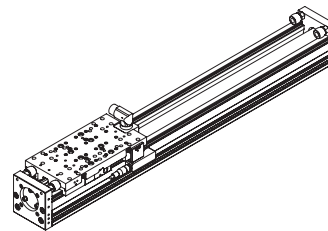

Ordering example 2 with external position measuring system and an additional slide

PDL40	50444527	HR 50472113	x	16640269
-------	----------	-------------	---	----------

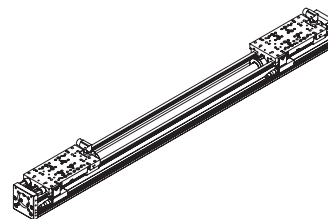

Ordering process

- Select the desired portal axis from the order key.
- Enter the corresponding red order numbers in the order form in the place of the cross.
- If an external position measuring system is desired, fill-in the corresponding letters from the coordinate system for the location and the order number.
- If clamping element is needed, fill-in the respective order number.
- If additional slides are needed, fill-in the respective order number several times correspondingly.

Additional slides

- The additional slide is always positioned to right of the current slide of the portal axis.

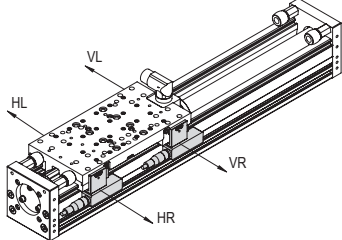
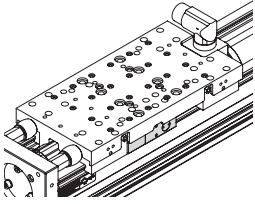
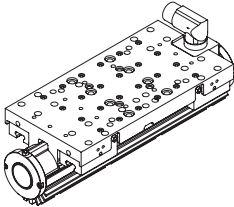
Portal axis	PDL40	XXXXXXXX	XX XXXXXXXX	XXXXXXXX	XXXXXXXX
	PDL40-170-D27	50444514	External position measuring system	Clamping element	Additional slide
	PDL40-230-D27	50444515			
	PDL40-320-D27	50444516			
	PDL40-440-D27	50444517			
	PDL40-530-D27	50444518			
	PDL40-70-D28	50444519			
	PDL40-160-D28	50444520			
	PDL40-280-D28	50444521			
	PDL40-370-D28	50444522			
	PDL40-460-D28	50444523			
	PDL40-580-D28	50444524			
	PDL40-670-D28	50444525			
	PDL40-880-D28	50444526			
	PDL40-1060-D28	50444527			
	PDL40-1270-D28	50444528			
	PDL40-1480-D28	50444529			
PDL40-1660-D28	50444530				
External position measuring system					
	Without				X
	Front right		VR 50472113		
	Back right		HR 50472113		
	Front left		VL 50472113		
	Back left		HL 50472113		
Clamping element	Without				X
	Clamping element			16640324 Clamping element PDL40/PDL40-HP	
Additional slide	Additional slide			16640269 Additional slide PDL40 with wiper 16640270 Additional slide PDL40 without wiper for slider D27	

The entire stroke of the portal axis is reduced by 299 mm for an additional slide with a D27 portal axis and by 324 mm with a D28 portal axis.
 The clamping element guarantees secure clamping in the event of power failure.
 Additional slide without wiper for high-clearance slider D27 only.

Portal axes PEL & PDL

PDL40-HP

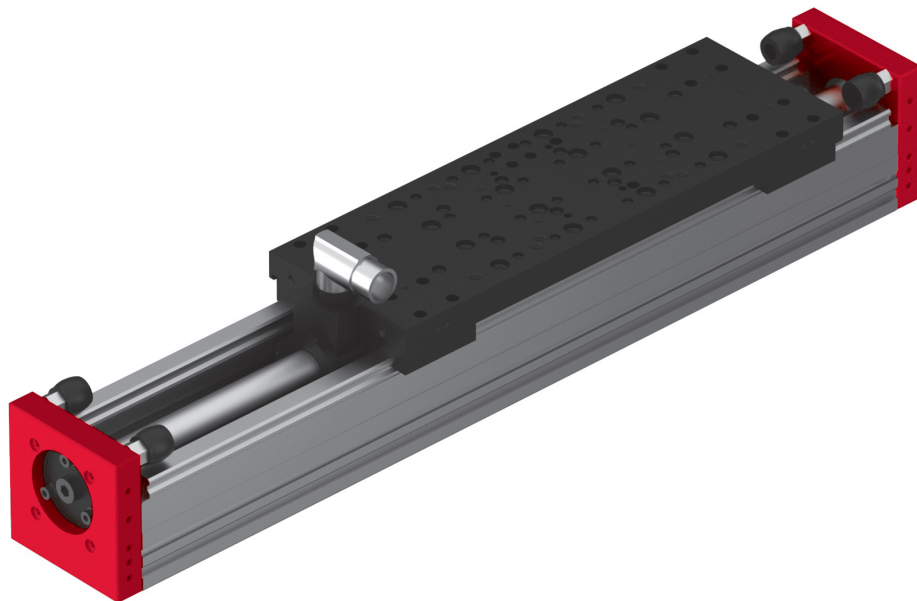

- Force package for highest demands
- Up to 1000 N peak force
- High force and dynamics even at high masses

Dimensions and dimension drawings

PDL40-HP

Type	PDL40-D27	PDL40-D28
A	49 mm	64 mm
L	H + 460 mm	H + 490 mm

- ① - 270° rotatable connector
- ② - External position measuring system
- ③ - Groove for sliding block size 8
- ④ - Groove for sliding block size 5

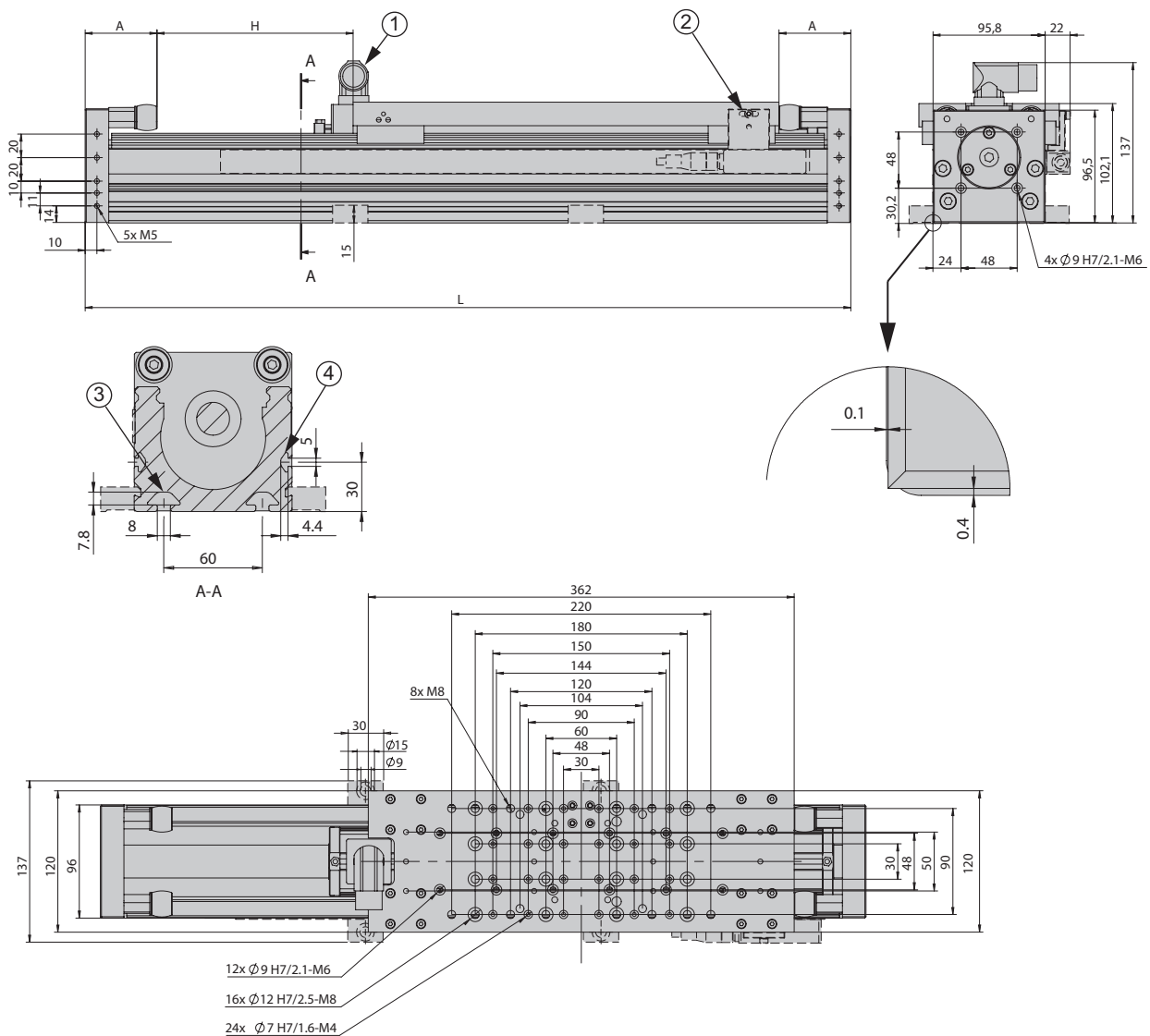



PDL40-HP	
Operating temperature	0 - 50 °C
Storage temperature	0 - 50 °C
Humidity	< 90 %

Type	PDL40-0200-HP-D27	PDL40-0320-HP-D27	PDL40-0410-HP-D27
Order number	50444532	50444533	50444534
Stroke H	200 mm	320 mm	410 mm
Net weight	14 kg	15.2 kg	16.1 kg
Max. speed		2 m/s	
Moving weight		6.3 kg	
Drive		Linear motor, electric	
Permanent force		203 N	
Peak force		1024 N	
Repeat accuracy		+/- 0.05 mm	
- with external position measuring system		+/- 0.02 mm	

Type	PDL40-0160-HP-D28	PDL40-0250-HP-D28	PDL40-0340-HP-D28	PDL40-0460-HP-D28	PDL40-0550-HP-D28	PDL40-0760-HP-D28
Order number	50444535	50444536	50444537	50444538	50444539	50444540
Stroke H	160 mm	250 mm	340 mm	460 mm	550 mm	760 mm
Net weight	13.6 kg	14.5 kg	15.4 kg	16.6 kg	17.5 kg	19.6 kg
Max. speed				2 m/s		
Moving weight				6.3 kg		
Drive				Linear motor, electric		
Permanent force				203 N		
Peak force				1024 N		
Repeat accuracy				+/- 0.05 mm		
- with external position measuring system				+/- 0.02 mm		

Type	PDL40-0940-HP-D28	PDL40-1150-HP-D28	PDL40-1360-HP-D28	PDL40-1540-HP-D28
Order number	50444541	50444542	50444543	50444544
Stroke H	940 mm	1150 mm	1360 mm	1540 mm
Net weight	21.4 kg	23.5 kg	25.6 kg	27.4 kg
Max. speed			2 m/s	
Moving weight			6.3 kg	
Drive		Linear motor, electric		
Permanent force		203 N		
Peak force		1024 N		
Repeat accuracy		+/- 0.05 mm		
- with external position measuring system		+/- 0.02 mm		
Mounting position is the same for all PDL40-HP		✦		

The technical data pertains to Afag standard test conditions.
 Note: For vertical installation, a weight compensation is required.
 Cleanroom class ISO 14644-1, class ISO 7

Included in the delivery

(Catalogue HT accessories)

- 4x Centering bushing Ø9x4

Accessories

- External position measuring system PDL30/40 [p. 365]
- Connecting set VS 516 [p. 366]

(Catalogue HT accessories)

- T-nut M8
- Motor cable-M17
- Controller C11xx-1S
- Plug kit for C1xxx-1S
- USB-RS232 Converter for controllers
- Power supply T01-72/1500 multi,3-phase





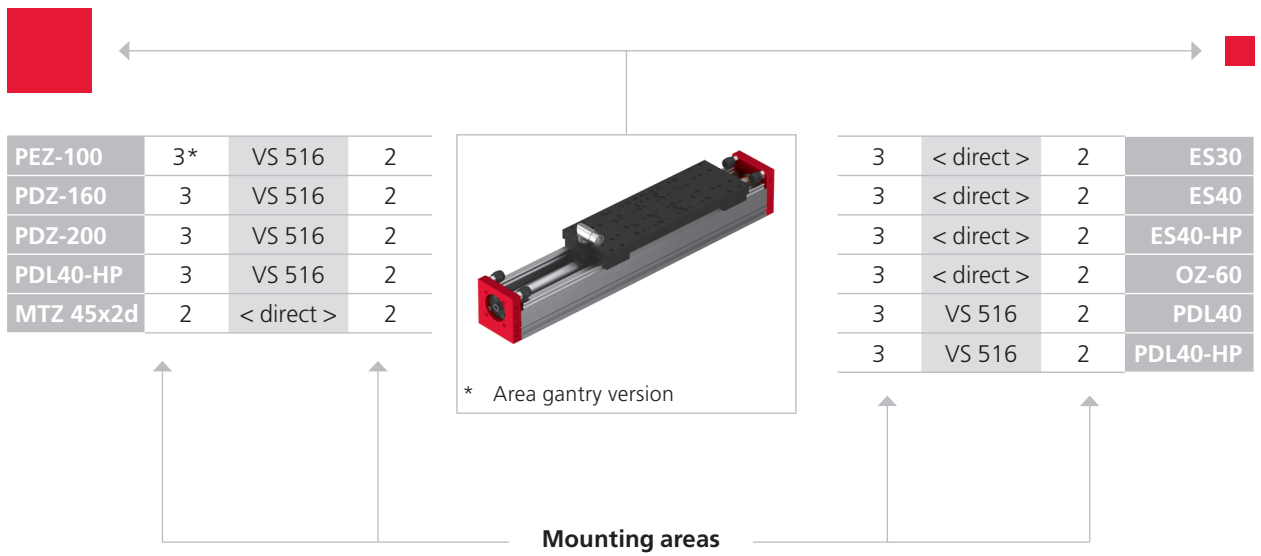

Alternative accessories

(Catalogue HT accessories)

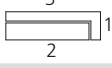
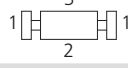
- Additional motor cables
- Additional controllers
- Additional power supplies
- Console in program for supports/columns
- Drag-chain on request

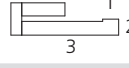
Warranty: 24 months following commissioning, but a maximum of 27 months following delivery

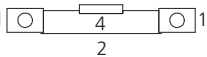
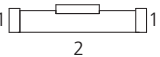

CS, ES	LM	HM	SA	UG, GM, SG, DG, PG, GE, SGE
				
PMP, PMP-c	PEZ, PDZ	PEL, PDL	RM, RE	CR, RM 32, RE, SREH, RA
				

Note that there might be different mounting positions from one module to another one.
 The required connection elements and the range of support columns are depicted in the catalogue HT accessories.

Type	PDL40-HP
Force F_y	4500 N
Force F_z	4500 N
Max. dynamic torque M_x	850 Nm
Max. dynamic torque M_y	3200 Nm
Max. dynamic torque M_z	3200 Nm

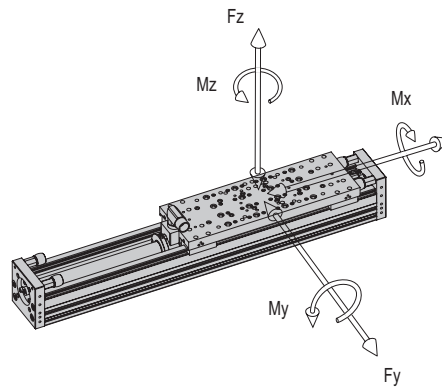

Maximum payload/type	PDL40-HP
Installation position (horizontal) for mounting side 3	85 kg
Installation position (vertical) for mounting side 3	85 kg

Assembly sides module mounting

horizontal:

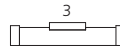

vertical:



PDL40-HP diagrams

Force range D27

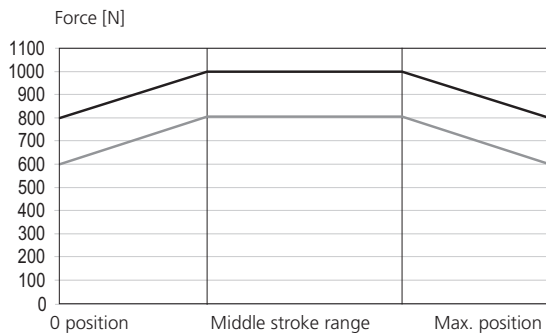

Middle stroke range
 PDL40-200-HP-D27 90 mm
 PDL40-320-HP-D27 180 mm
 PDL40-410-HP-D27 270 mm

Controller UC (32 A)
 Controller XC (25 A)

Operation time diagram

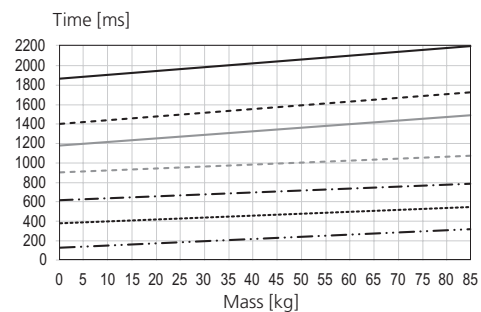

Stroke
 1500
 1200
 900
 700
 500
 300
 100

Running times based on pause times of 200 ms

Order form	PDL40-HP	XXXXXXXX	XX XXXXXXXX	XXXXXXXX	XXXXXXXX
		Portal axis	External position measuring system	Clamping element	Additional slides

Coordinate system

The coordinate system allows you to define the position of the external position measuring system.

- VR= front right
- HR= back right
- VL= front left
- HL= back left

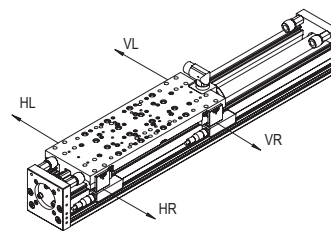

Ordering example 1 without external position measuring system, without clamping element and without additional slide

PDL40-HP	50444533	x	x	x
----------	----------	---	---	---

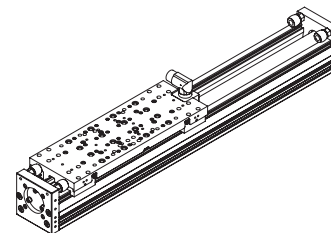

Ordering example 2 with external position measuring system and clamping element and without additional slide

PDL40-HP	50444533	HR 50472113	16640324	x
----------	----------	-------------	----------	---

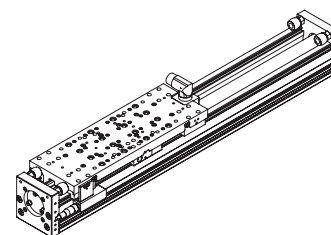

Ordering process

- Select the desired portal axis from the order key.
- Enter the corresponding red order numbers in the order form in the place of the cross.
- If you want an external position measuring system, select the position of the external position measuring system.
- Enter the corresponding letters from the coordinate system in the order form in the place of the cross.
- When selecting a clamping element, write X if they are not required and write 1 if they are required.
- If an external position measuring system is desired, fill-in the corresponding letters from the coordinate system for the location and the order number.
- If clamping element is needed, fill-in the respective order number.
- If additional slides are needed, fill-in the respective order number several times correspondingly.

Additional slides

- The additional slide is always positioned to right of the current slide of the portal axis.

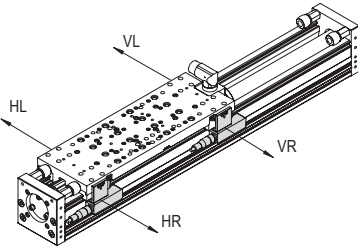
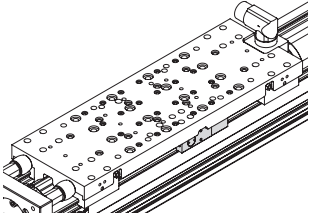
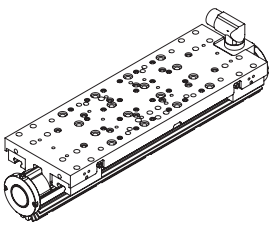
	PDL40-HP	XXXXXXXX	XX XXXXXXXX	XXXXXXXX	XXXXXXXX
Portal axis	PDL40-200-HP-D27	50444532	External position measuring system	Clamping element	Additional slide
	PDL40-320-HP-D27	50444533			
	PDL40-410-HP-D27	50444534			
	PDL40-160-HP-D28	50444535			
	PDL40-250-HP-D28	50444536			
	PDL40-340-HP-D28	50444537			
	PDL40-460-HP-D28	50444538			
	PDL40-550-HP-D28	50444539			
	PDL40-760-HP-D28	50444540			
	PDL40-940-HP-D28	50444541			
	PDL40-1150-HP-D28	50444542			
	PDL40-1360-HP-D28	50444543			
	PDL40-1540-HP-D28	50444544			
External position measuring system					
	Without			X	
	Front right		VR 50472113		
	Back right		HR 50472113		
	Front left		VL 50472113		
Back left		HL 50472113			
Clamping element	Without			X	
	Clamping element				 16640324 Clamping element PDL40/PDL40-HP
Additional slide					
	Additional slide				16640279 Additional slide PDL40-HP with wiper 50559618 Additional slide PDL40-HP without wiper for slide D27

The entire stroke of the portal axis is reduced by 419 mm for an additional slide with a D27 portal axis and by 444 mm with a D28 portal axis.

The clamping element guarantees secure clamping in the event of power failure.

Additional slide without wiper for high-clearance slider D27 only.

Accessories PEL & PDL

External position measuring system PEL20/-SL

Order number

50472112

A: Stroke + 100 mm

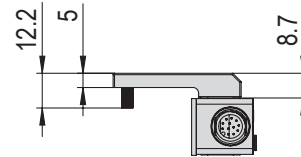
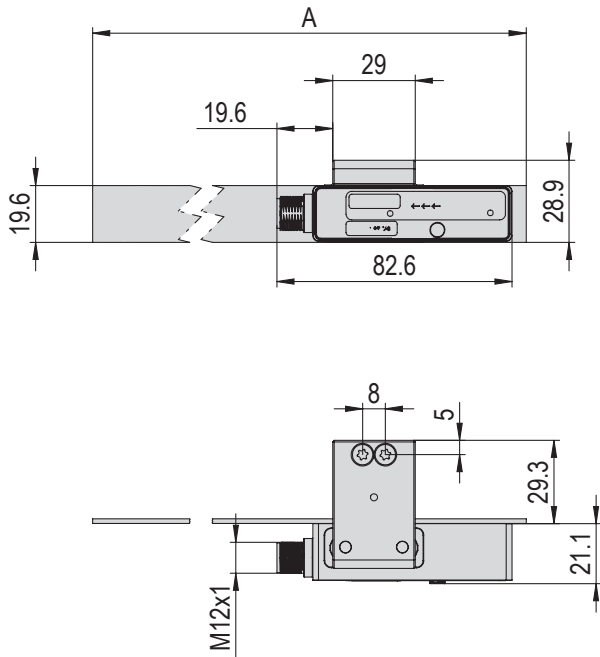

Included in the delivery

- 2x Mounting screw M4x12

External position measuring system PDL30/PDL40/PDL40/-HP

Order number

50472113

A: Stroke + 100 mm

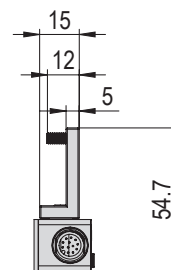
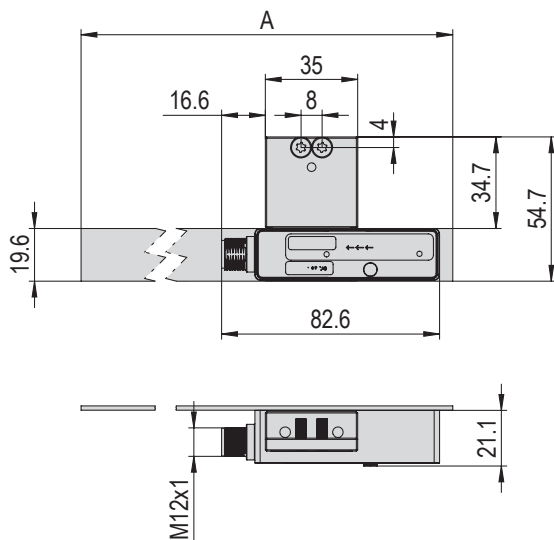

Included in the delivery

- 2x Mounting screw M4x12

Accessories PEL & PDL

Connecting set VS 516

Order number

50471445

Suitable for

PEL, PDL

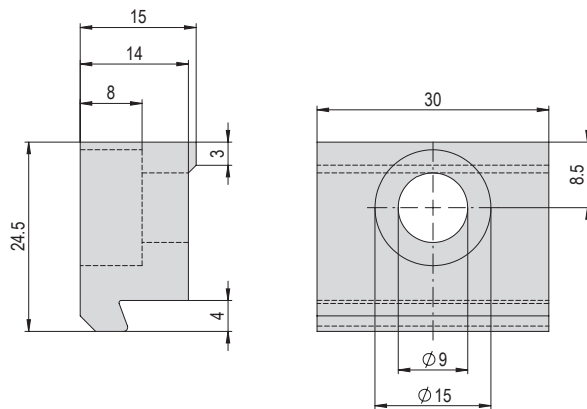

Included in the delivery

- 1x Clamping jaws PEL20, PDL30 & PDL40
- 1x Mounting screw M8x20
- 1x Washer M8