

Compact slides CS

CS 6 - CS 25

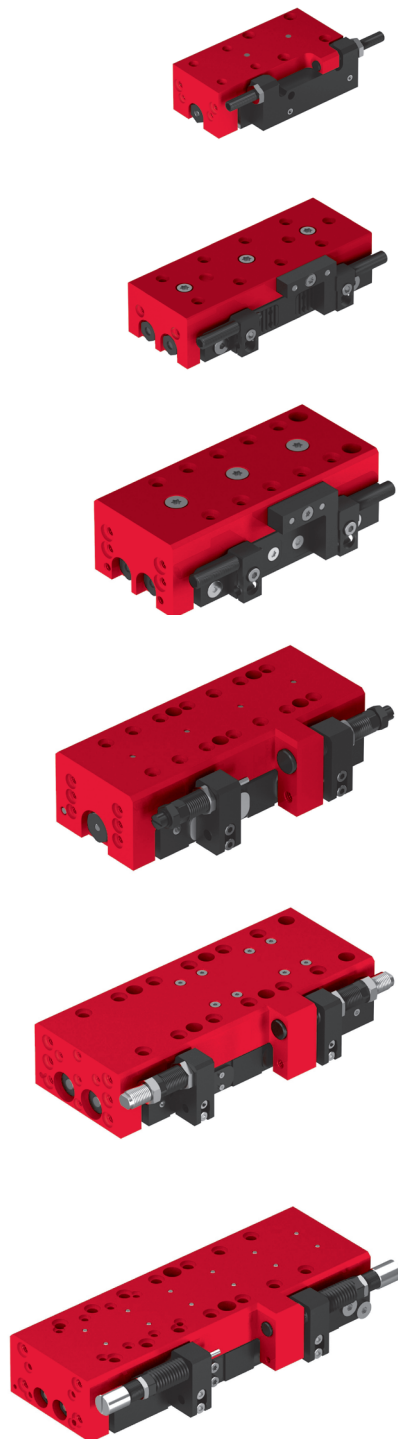
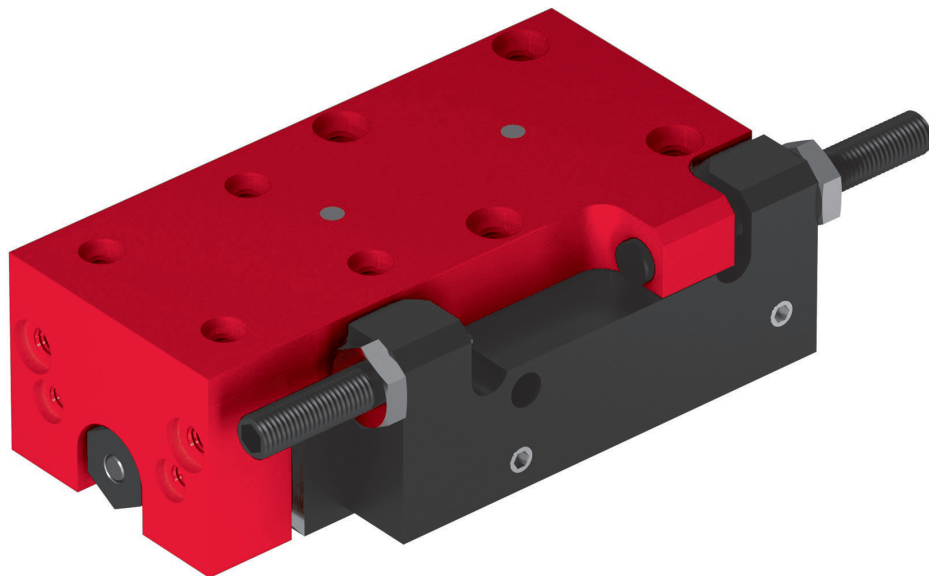

Table of Contents: CS

Compact slides CS	Page
CS 6	9
CS 8	15
CS 12	23
CS 16	31
CS 20	37
CS 25	43
Accessories CS	49

Compact slides CS

CS 6



- Compact design
- Solid construction
- High rigidity

Type	CS 6/20-ED	CS 6/40-ED
A	60.5 mm	80.5 mm
B	29 mm	49 mm
C	1 x 20 mm	2 x 20 mm
P	M3	M3

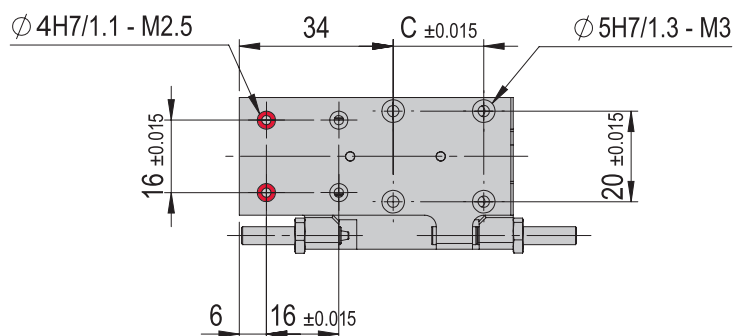
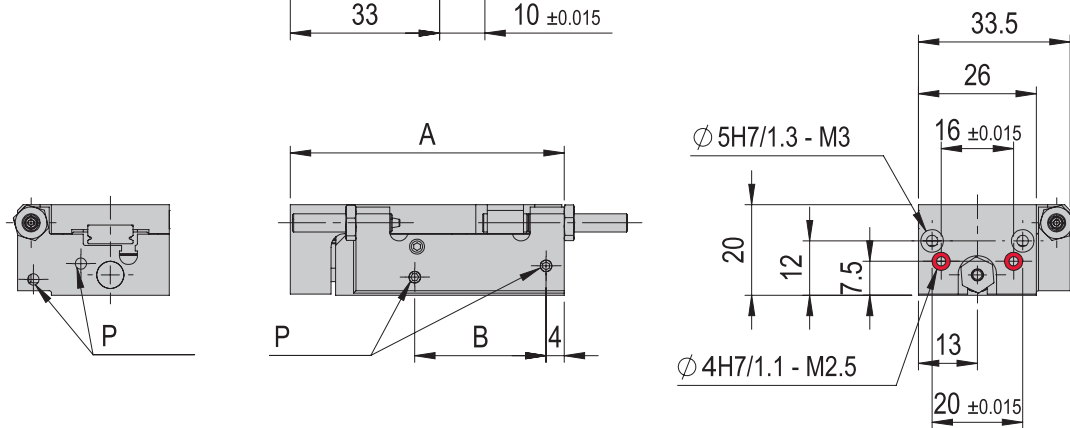
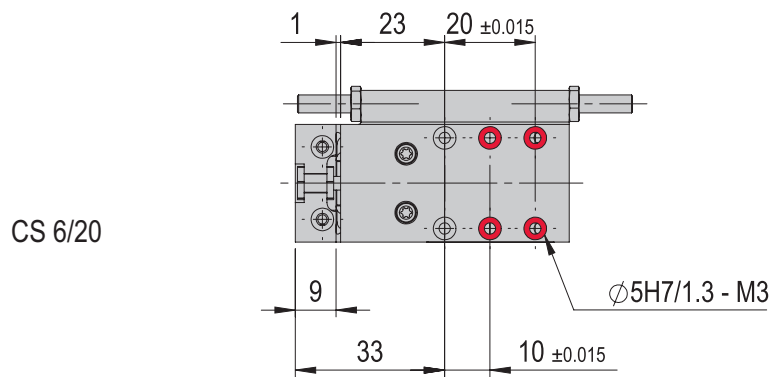
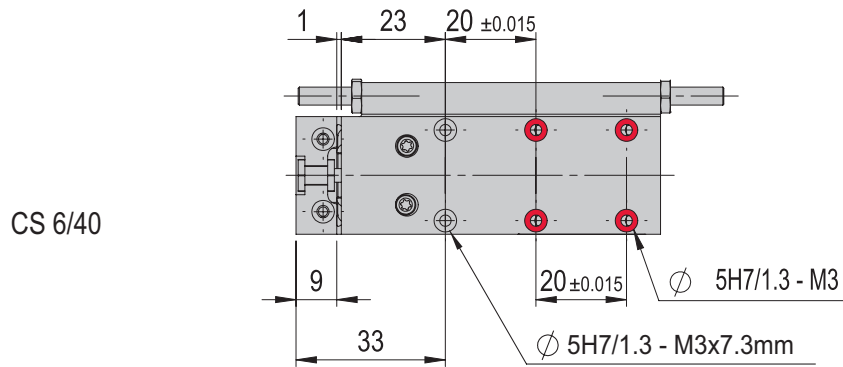

 Bores can be screwed through

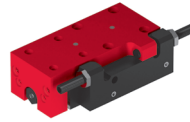

CS 6	
Attachment grid	20 x 20 mm
Attachment grid alternative	16 x 16 mm
Attachment thread	M3
Attachment thread alternative	M2.5
Operating pressure	6 +/- 2 bar
Air connection P	M3
Cylinder Ø	6 mm
Retract piston force	12 N
Extend piston force	17 N
Operating temperature	0 - 50 °C
Storage temperature	0 - 50 °C
Humidity	< 90 %
Medium filtered compressed air	10 - 40 µm

Type	CS 6/20-ED	CS 6/40-ED
Order number	50386049	50386050
Stroke H	20 mm	40 mm
Stroke limitation	2 x 10 mm	2 x 10 mm
Net weight	0.11 kg	0.14 kg
Moving weight	0.05 kg	0.065 kg
Air consumption/cycle	0.005 NL	0.009 NL
Noise level	60 dB (A)	60 dB (A)
Repeat accuracy	+/- 0.01 mm	+/- 0.01 mm
Maximum speed	1 m/s	1 m/s
Minimum speed	0.05 m/s	0.05 m/s
Mounting position	↕	↕

The technical data refers to a nominal pressure of 6 bar under Afag standard test conditions. The maximum payloads are listed in the payloads table in the slide loads section. The module can be operated with lubricated or dry air. Cleanroom class ISO 14644-1, class ISO 7

Included in the delivery (Catalogue HT accessories)

- 2x Centering bushing Ø5x2.5
- 2x Special screw M3x14.8/4
- 2x Special screw M3 x 16/6
- 2x Shock absorber ASED M4x0.5 -1
- 2x Set screw M3x3

Accessories (Catalogue HT accessories)

- INI c10x20-Em-PNP-NO-M8x1

Warranty: 24 months following commissioning, but a maximum of 27 months following delivery

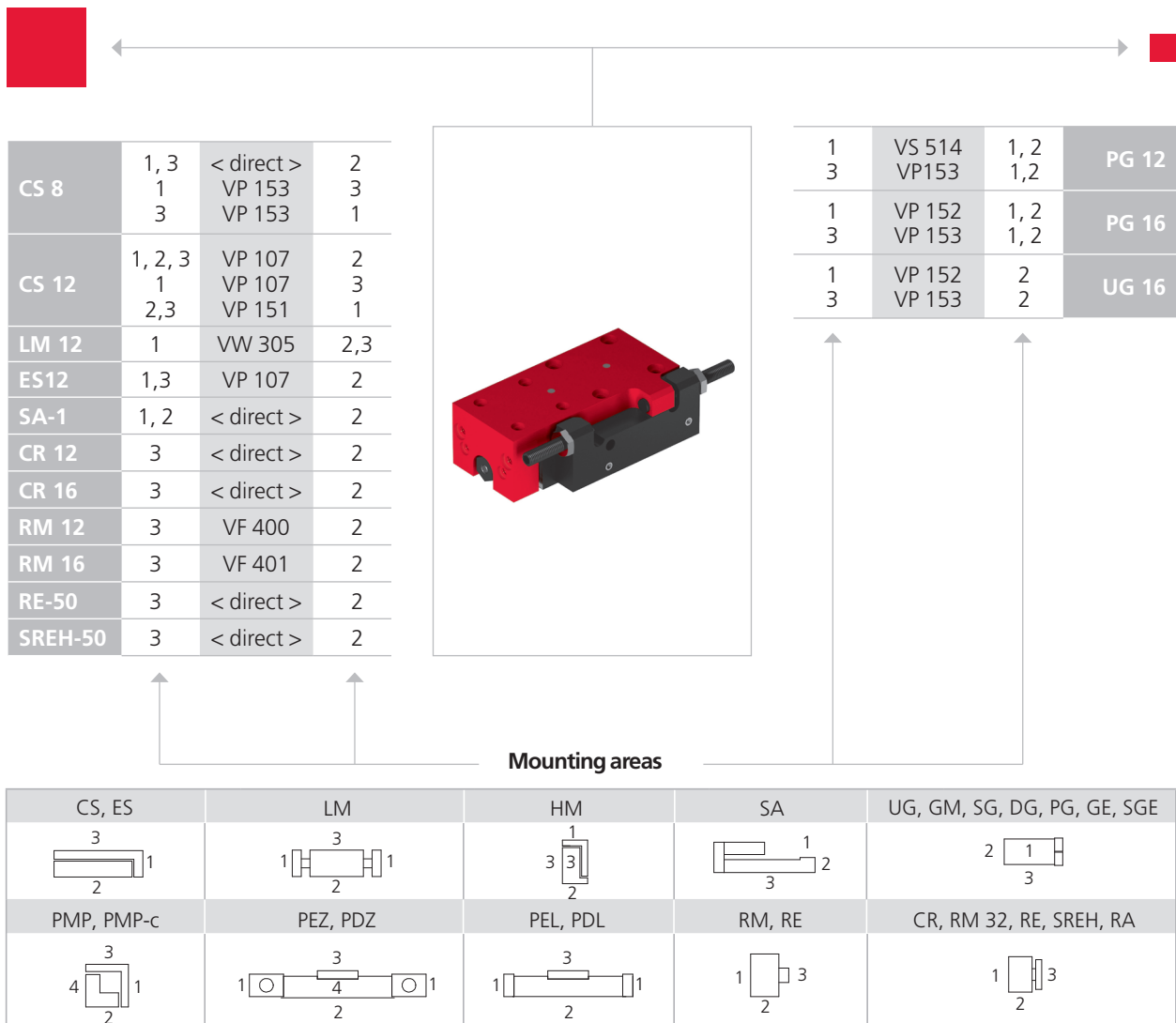

Note that there might be different mounting positions from one module to another one.

The required connection elements and the range of support columns are depicted in the catalogue HT accessories.

Type	CS 6/20-ED	CS 6/40-ED
Max. torque M_x	1.9 Nm	1.9 Nm
Max. torque M_y	1.3 Nm	1.3 Nm
Max. torque M_z	1.3 Nm	1.3 Nm
Effective distance W_x	25 mm	25 mm
Effective distance W_y	18 mm	18 mm
Effective distance W_z	7 mm	7 mm

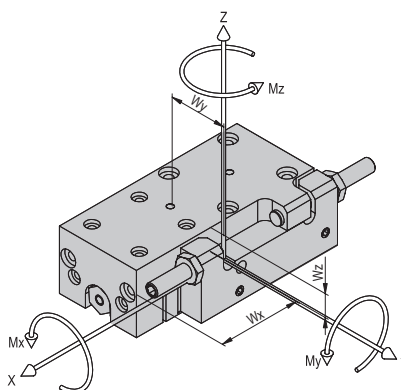

Maximum payload/type	CS 6/20-ED	CS 6/40-ED
Installation position (horizontal) for mounting side 1	0.08 kg	0.08 kg
Installation position (horizontal) for mounting side 3	0.1 kg	0.1 kg
Installation position (vertical) for mounting side 1	0.08 kg	0.08 kg
Installation position (vertical) for mounting side 3	0.1 kg	0.1 kg

Assembly sides
module mounting

horizontal:

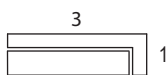

vertical:

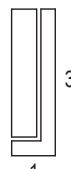

If the specified maximum payloads are exceeded, it must be ensured that the corresponding moments do not affect the service life of the module. In the event of critical applications, please contact Afag.

Operation time diagrams

CS 6/20-ED

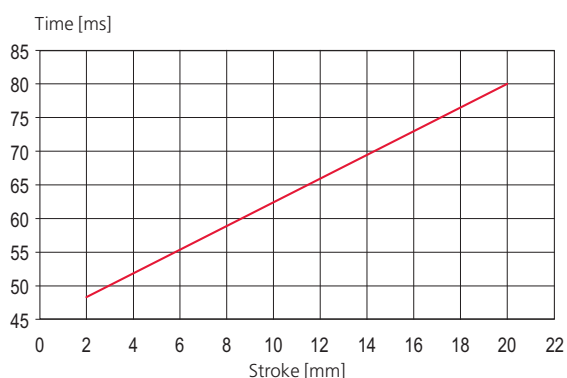

CS 6/40-ED

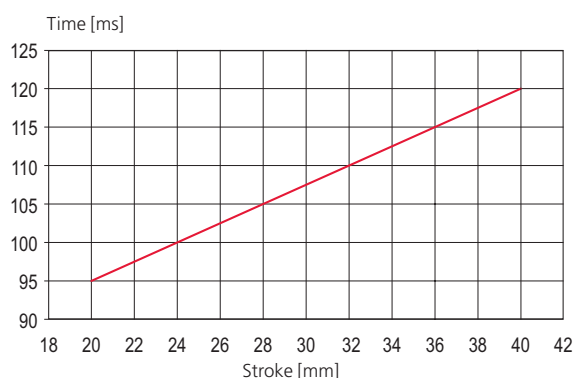

Compact slides CS

CS 8

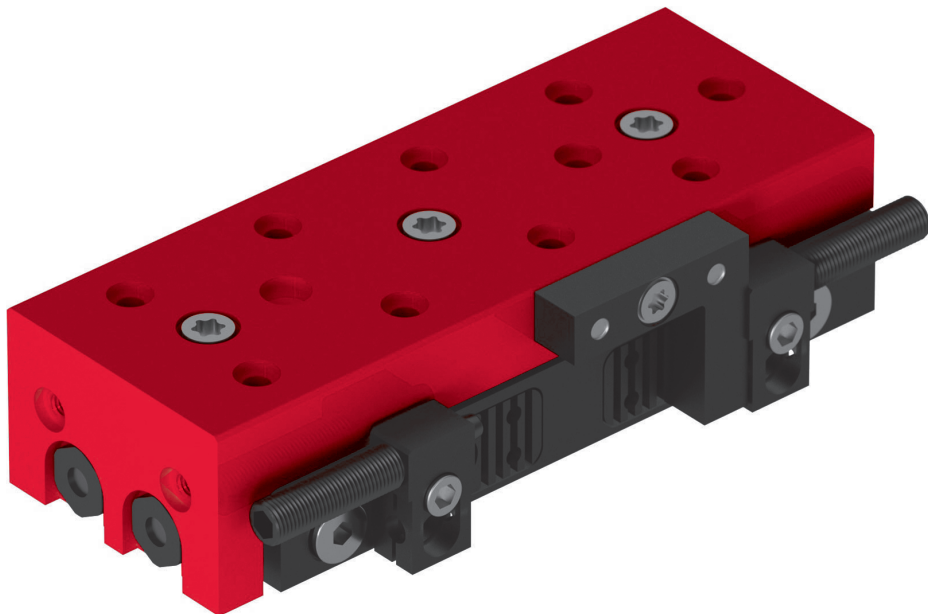

- Compact design
- Solid construction
- High rigidity

Type	CS 8/10	CS 8/30	CS 8/60
A	54 mm	90 mm	120 mm
B		66 mm	96 mm
C	7.5 mm	11 mm	8 mm
D	2 x 20 mm	3 x 20 mm	5 x 20 mm
E	20 mm	3 x 20 mm	4 x 20 mm
F		23.5 mm	23.5 mm
G	Screw-through (CS 8/30 and CS 8/60)		
P	M5	M5	M5

CS 8/60

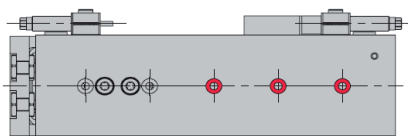

CS 8/30

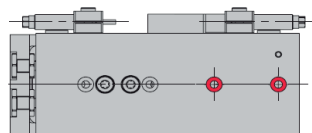

CS 8/10

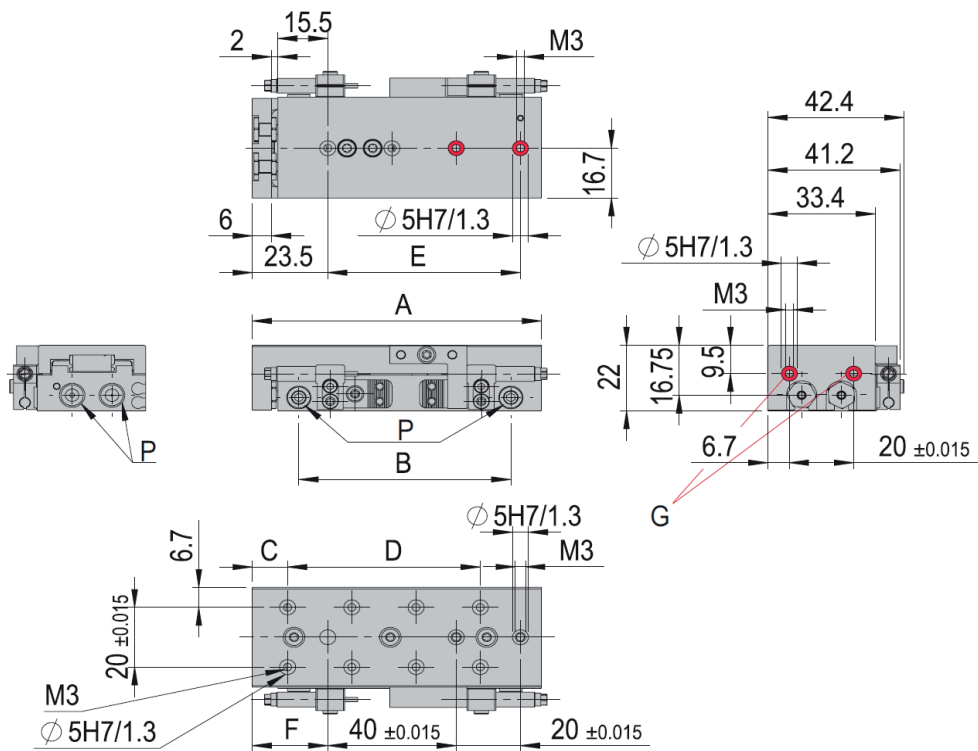
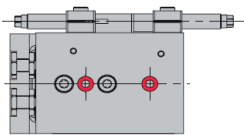

 Bores can be screwed through

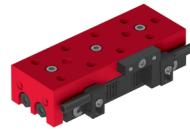

CS 8	
Attachment grid	20 x 20 mm
Attachment thread	M3
Operating pressure	6 +/- 2 bar
Air connection P	M5
Cylinder Ø	2 x 6 mm
Retract piston force	25 N
Extend piston force	34 N
Operating temperature	0 - 50 °C
Storage temperature	0 - 50 °C
Humidity	< 90 %
Medium filtered compressed air	10 - 40 µm

Type	CS 8/10-ED	CS 8/10-SD	CS 8/30-ED	CS 8/30-SD	CS 8/60-ED	CS 8/60-SD
Order number	50300525	50036720	50300526	50035820	50300527	50035829
Stroke H	10 mm	10 mm	30 mm	30 mm	60 mm	60 mm
Stroke limitation	2 x 10 mm	2 x 10 mm	2 x 25 mm	2 x 25 mm	2 x 25 mm	2 x 25 mm
Net weight	0.176 kg	0.175 kg	0.241 kg	0.24 kg	0.288 kg	0.287 kg
Moving weight	0.07 kg	0.07 kg	0.11 kg	0.11 kg	0.14 kg	0.14 kg
Air consumption/cycle	0.005 NL	0.005 NL	0.014 NL	0.014 NL	0.027 NL	0.027 NL
Noise level	60 dB (A)	60 dB (A)	60 dB (A)	60 dB (A)	60 dB (A)	60 dB (A)
Repeat accuracy	+/- 0.01 mm	+/- 0.01 mm	+/- 0.01 mm	+/- 0.01 mm	+/- 0.01 mm	+/- 0.01 mm
Maximum speed	1 m/s	1 m/s	1 m/s	1 m/s	1 m/s	1 m/s
Minimum speed	0.05 m/s	0.05 m/s	0.05 m/s	0.05 m/s	0.05 m/s	0.05 m/s
Mounting position	✦	✦	✦	✦	✦	✦

The technical data refers to a nominal pressure of 6 bar under Afag standard test conditions. The maximum payloads are listed in the payloads table in the slide loads section.
 Note: the CS 8/...-ED are supplied with an elastomer damper ASED
 The CS 8/...-SD are supplied with a hydraulic shock absorber ASSD
 The CS 8/...-SDH are supplied with a hydraulic shock absorber and with a stop sleeve
 The module can be operated with lubricated or dry air.
 Cleanroom class ISO 14644-1, class ISO 7

Included in the delivery

(Catalogue HT accessories)

- 2x Centering bushing Ø5x2.5
- 2x Special screw M3x14.8/4
- 2x Special screw M3 x 16/6
- 2x Shock absorber ASSD M5x0.5 -2
- 2x Shock absorber ASED M5x05 -1

Accessories

(Catalogue HT accessories)

- INI c10x28.5-Em-PNP-NO-M8x1

Alternative accessories

(Catalogue HT accessories)

- Steel stop ASS 05/12
- Steel stop ASS 05/22
- Steel stop ASS 05/37
- Steel stop ASS 03/25
- INI d3x22-Sn0.8-PNP-NO-M8x1
- INI c10x19.5-Em-PNP-NO-M8x1

Warranty: 24 months following commissioning, but a maximum of 27 months following delivery

Type	CS 8/10-SDH	CS 8/30-SDH	CS 8/60-SDH
A	54 mm	90 mm	120 mm
B		66 mm	96 mm
C	7.5 mm	11 mm	8 mm
D	2 x 20 mm	3 x 20 mm	5 x 20 mm
E	20 mm	3 x 20 mm	4 x 20 mm
F		23.5 mm	23.5 mm
G	Screw-through (CS 8/30 and CS 8/60)		
P	M5	M5	M5

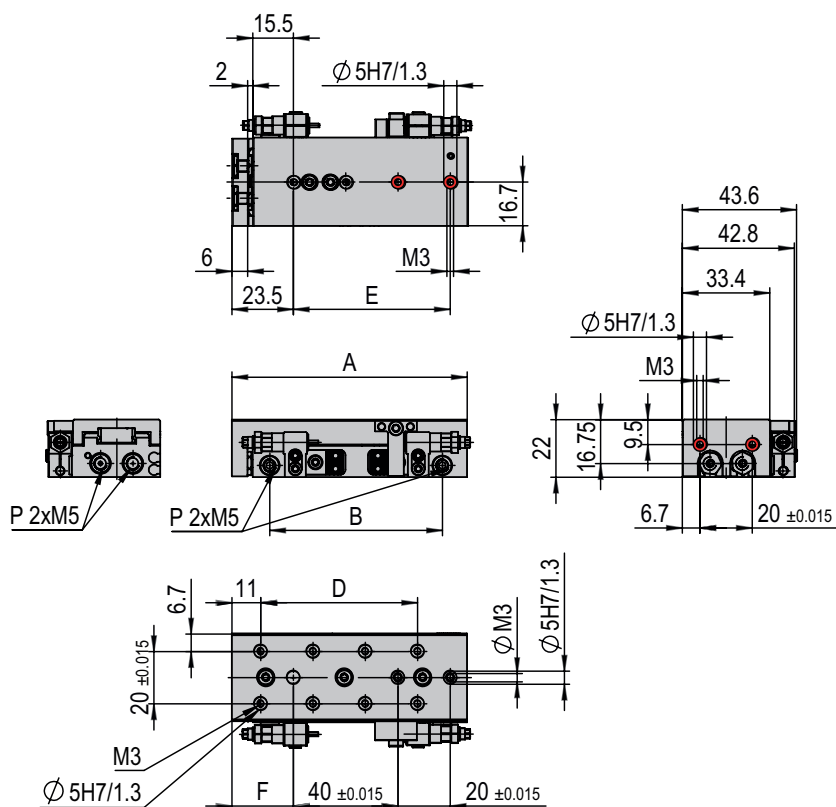
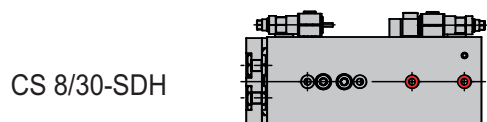
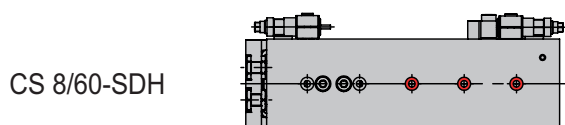

Bores can be screwed through

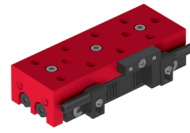

CS 8	
Attachment grid	20 x 20 mm
Attachment thread	M3
Operating pressure	6 +/- 2 bar
Air connection P	M5
Cylinder Ø	2 x 6 mm
Retract piston force	25 N
Extend piston force	34 N
Operating temperature	0 - 50 °C
Storage temperature	0 - 50 °C
Humidity	< 90 %
Medium filtered compressed air	10 - 40 µm

Type	CS 8/10-SDH	CS 8/30-SDH	CS 8/60-SDH
Order number	50509361	50509609	50509576
Stroke H	10 mm	30 mm	60 mm
Stroke limitation	2 x 10 mm	2 x 25 mm	2 x 25 mm
Net weight	0.181 kg	0.246 kg	0.293 kg
Moving weight	0.07 kg	0.11 kg	0.14 kg
Air consumption/cycle	0.005 NL	0.014 NL	0.027 NL
Noise level	60 dB (A)	60 dB (A)	60 dB (A)
Repeat accuracy	+/- 0.01 mm	+/- 0.01 mm	+/- 0.01 mm
Maximum speed	1 m/s	1 m/s	1 m/s
Minimum speed	0.05 m/s	0.05 m/s	0.05 m/s
Mounting position	✦	✦	✦

The technical data refers to a nominal pressure of 6 bar under Afag standard test conditions. The maximum payloads are listed in the payloads table in the slide loads section.

Note: the CS 8/...-ED are supplied with an elastomer damper ASED

The CS 8/...-SD are supplied with a hydraulic shock absorber ASSD

The CS 8/...-SDH are supplied with a hydraulic shock absorber and with a stop sleeve

The module can be operated with lubricated or dry air.

Cleanroom class ISO 14644-1, class ISO 7

Included in the delivery

(Catalogue HT accessories)

- 2x Centering bushing Ø5x2.5
- 2x Special screw M3x14.8/4
- 2x Special screw M3 x 16/6
- 2x Shock absorber ASSD M5x0.5 -2
- 2x Shock absorber ASED M5x05 -1

Accessories

(Catalogue HT accessories)

- INI c10x28.5-Em-PNP-NO-M8x1

Alternative accessories

(Catalogue HT accessories)

- Steel stop ASS 05/12
- Steel stop ASS 05/22
- Steel stop ASS 05/37
- Steel stop ASS 03/25
- INI d3x22-Sn0.8-PNP-NO-M8x1
- INI c10x19.5-Em-PNP-NO-M8x1

Warranty: 24 months following commissioning, but a maximum of 27 months following delivery

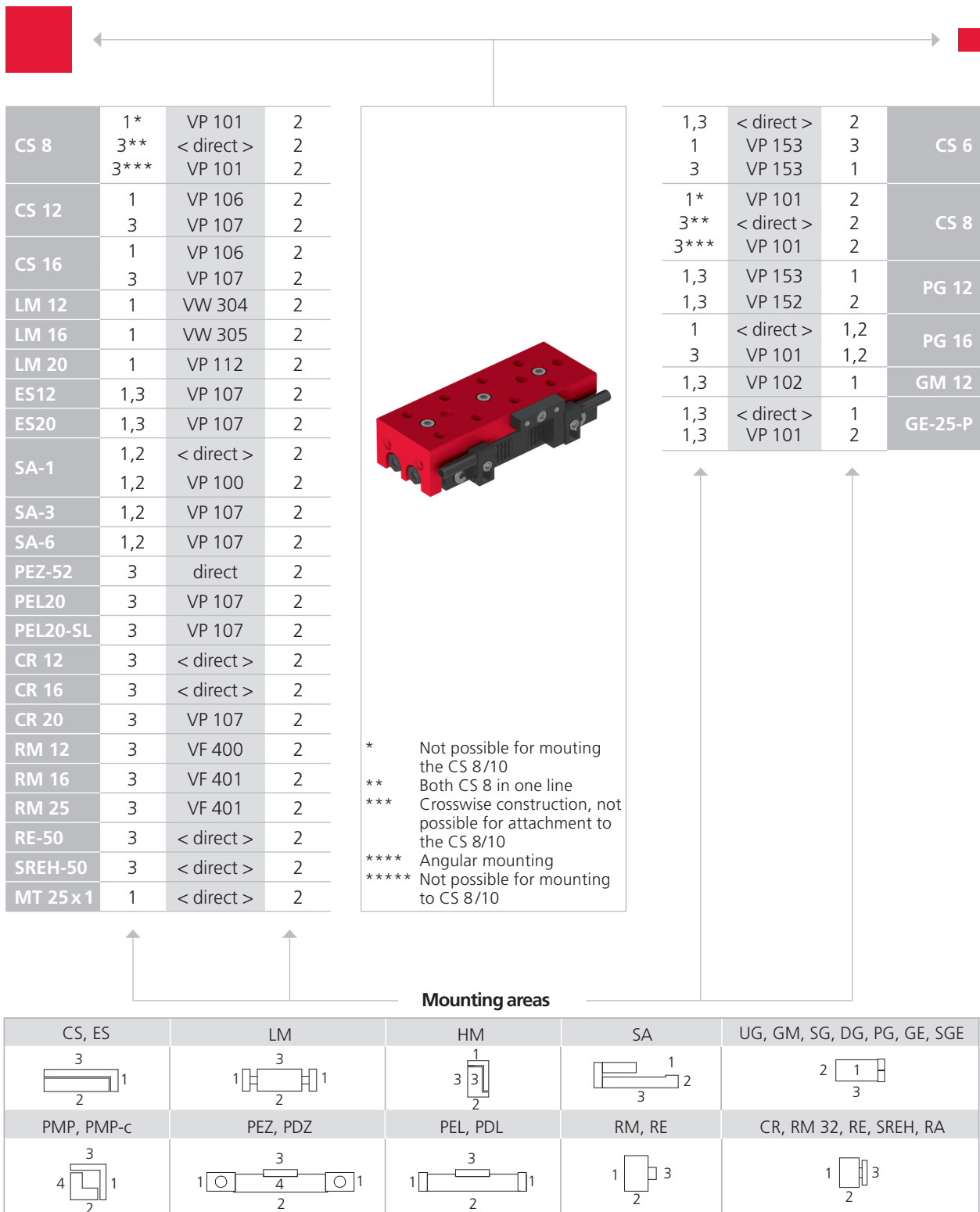

Note that there might be different mounting positions from one module to another one.
 The required connection elements and the range of support columns are depicted in the catalogue HT accessories.

Type	CS 8/10-ED	CS 8/10-SD	CS 8/10-SDH	CS 8/30-ED	CS 8/30-SD	CS 8/30-SDH	CS 8/60-ED	CS 8/60-SD	CS 8/60-SDH
Max. torque Mx	3.6 Nm	3.6 Nm	3.6 Nm	5.4 Nm	5.4 Nm	5.4 Nm	5.4 Nm	5.4 Nm	5.4 Nm
Max. torque My	1.7 Nm	1.7 Nm	1.7 Nm	3.6 Nm	3.6 Nm	3.6 Nm	3.6 Nm	3.6 Nm	3.6 Nm
Max. torque Mz	1.7 Nm	1.7 Nm	1.7 Nm	3.6 Nm	3.6 Nm	3.6 Nm	3.6 Nm	3.6 Nm	3.6 Nm
Effective distance Wx	24 mm	24 mm	24 mm	28 mm	28 mm	28 mm	28 mm	28 mm	28 mm
Effective distance Wy	20 mm	20 mm	20 mm	20 mm	20 mm	20 mm	20 mm	20 mm	20 mm
Effective distance Wz	6.5 mm	6.5 mm	6.5 mm	6.5 mm	6.5 mm	6.5 mm	6.5 mm	6.5 mm	6.5 mm

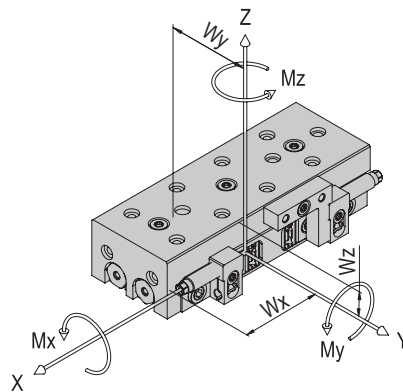

Maximum payload/type	CS 8/10-ED	CS 8/10-SD	CS 8/10-SDH	CS 8/30-ED	CS 8/30-SD	CS 8/30-SDH	CS 8/60-ED	CS 8/60-SD	CS 8/60-SDH
Installation position (horizontal) for mounting side 1	0.2 kg	0.3 kg	0.3 kg	0.2 kg	0.4 kg	0.4 kg	0.2 kg	0.4 kg	0.4 kg
Installation position (horizontal) for mounting side 3	0.2 kg	0.3 kg	0.3 kg	0.2 kg	0.7 kg	0.7 kg	0.2 kg	0.7 kg	0.7 kg
Installation position (vertical) for mounting side 1	0.2 kg	0.3 kg	0.3 kg	0.2 kg	0.4 kg	0.4 kg	0.2 kg	0.4 kg	0.4 kg
Installation position (vertical) for mounting side 3	0.2 kg	0.3 kg	0.3 kg	0.2 kg	0.7 kg	0.7 kg	0.2 kg	0.7 kg	0.7 kg

Assembly sides module mounting

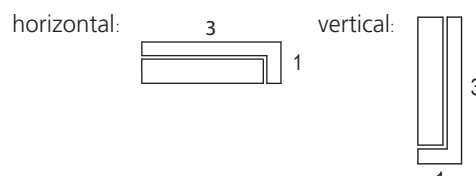

If the specified maximum payloads are exceeded, it must be ensured that the corresponding moments do not affect the service life of the module. In the event of critical applications, please contact Afag.

Operation time diagrams

CS 8/10-ED elastomer

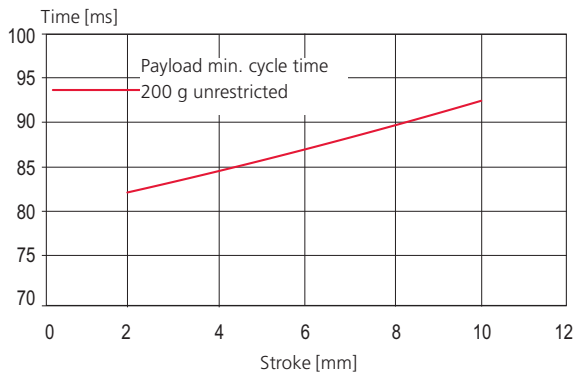

CS 8/10-SD hydraulic

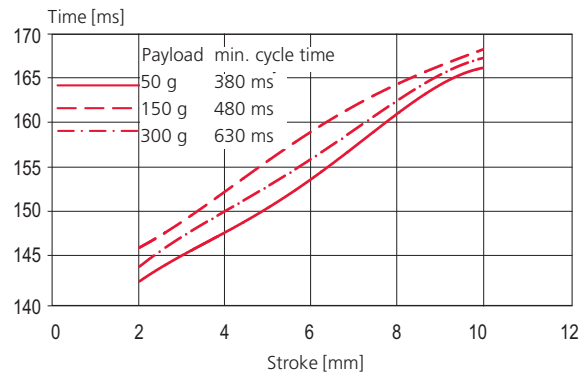

CS 8/30-ED elastomer

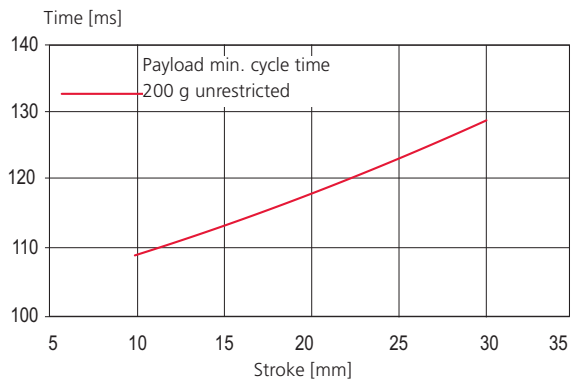

CS 8/30-SD hydraulic

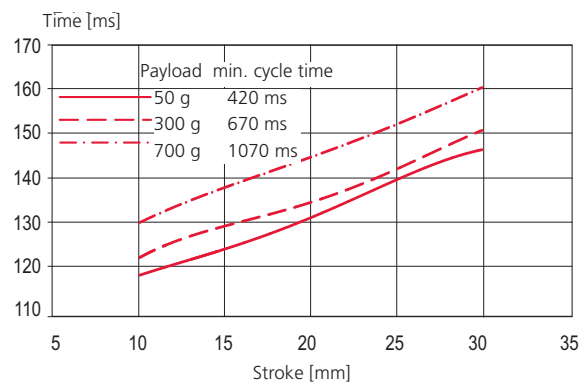

CS 8/60-ED elastomer

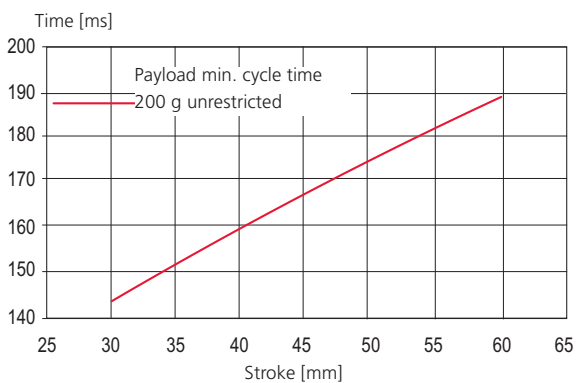

CS 8/60-SD hydraulic

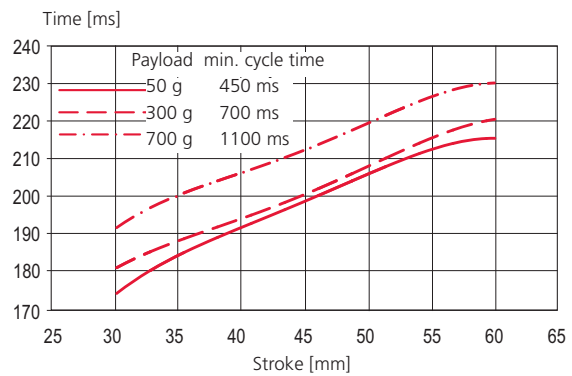

Compact slides CS

CS 12

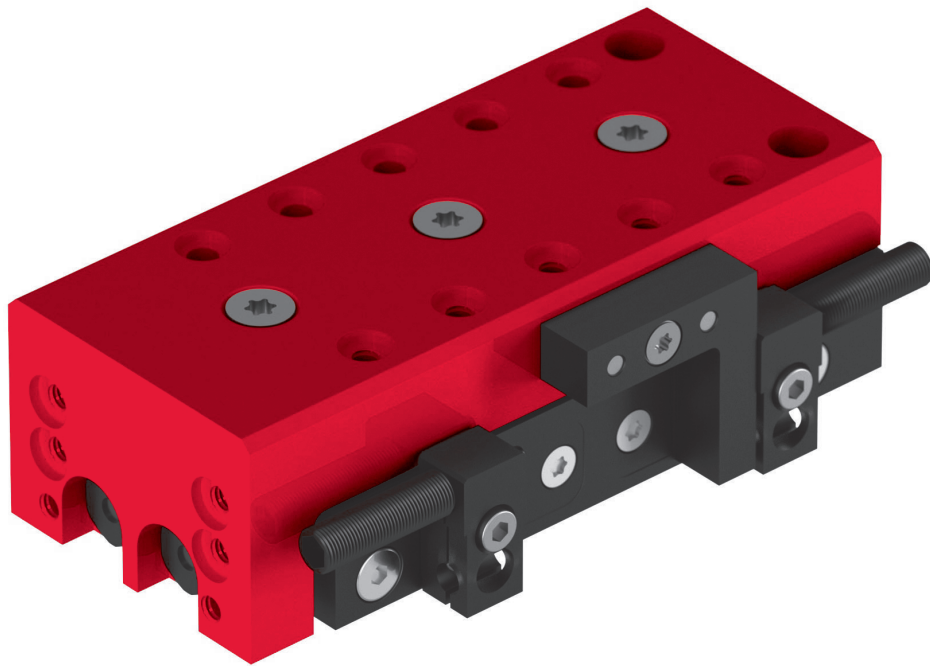

- Compact design
- Solid construction
- High rigidity

Type	CS 12/30	CS 12/60	CS 12/90
A	102 mm	132 mm	162 mm
B	70 mm	100 mm	130 mm
C	4 x 15 mm	6 x 15 mm	8 x 15 mm
D	4 x 15 mm	6 x 15 mm	8 x 15 mm

CS 12/90

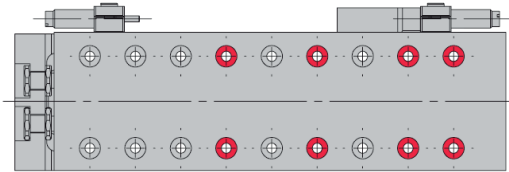

CS 12/60

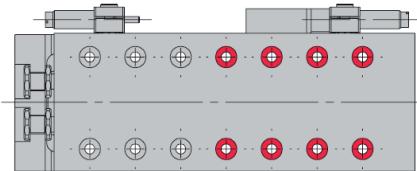

CS 12/30

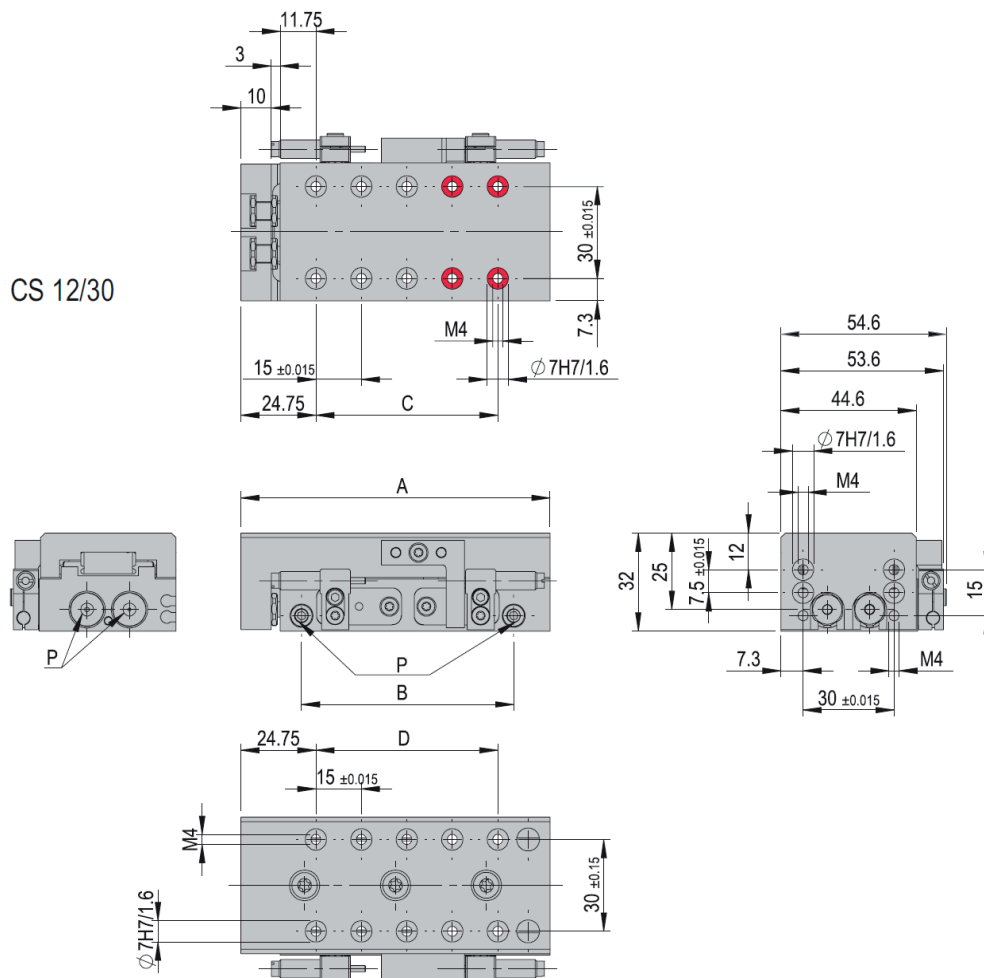

Bores can be screwed through

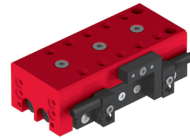

CS 12	
Attachment grid	30 x 30 mm
Attachment thread	M4
Operating pressure	6 +/- 2 bar
Air connection P	M5
Cylinder Ø	2 x 10 mm
Retract piston force	71 N
Extend piston force	94 N
Operating temperature	0 - 50 °C
Storage temperature	0 - 50 °C
Humidity	< 90 %
Medium filtered compressed air	10 - 40 µm

Typ	CS 12/30-ED	CS 12/30-SD	CS 12/60-ED	CS 12/60-SD	CS 12/90-ED	CS 12/90-SD
Bestellnummer	50300528	50048476	50300529	50050602	50300530	50050825
Stroke H	30 mm	30 mm	60 mm	60 mm	90 mm	90 mm
Stroke limitation	2 x 25 mm	2 x 25 mm	2 x 25 mm	2 x 25 mm	2 x 25 mm	2 x 25 mm
Net weight	0.5 kg	0.5 kg	0.864 kg	0.61 kg	0.73 kg	0.73 kg
Moving weight	0.24 kg	0.24 kg	0.3 kg	0.3 kg	0.36 kg	0.36 kg
Air consumption/cycle	0.038 NL	0.038 NL	0.076 NL	0.076 NL	0.114 NL	0.114 NL
Noise level	64 dB (A)	64 dB (A)	64 dB (A)	64 dB (A)	64 dB (A)	64 dB (A)
Repeat accuracy	+/- 0.01 mm	+/- 0.01 mm	+/- 0.01 mm	+/- 0.01 mm	+/- 0.01 mm	+/- 0.01 mm
Maximum speed	1 m/s	1 m/s	1 m/s	1 m/s	1 m/s	1 m/s
Minimum speed	0.02 m/s	0.02 m/s	0.02 m/s	0.02 m/s	0.02 m/s	0.02 m/s
Mounting position	↕	↕	↕	↕	↕	↕

The technical data refers to a nominal pressure of 6 bar under Afag standard test conditions. The maximum payloads are listed in the payloads table in the slide loads section.

Note: the CS 12/...-ED are supplied with an elastomer damper ASED

The CS 12/...-SD are supplied with a hydraulic shock absorber ASSD

The CS 12/...-SDH are supplied with a hydraulic shock absorber and with a stop sleeve

The module can be operated with lubricated or dry air.

Cleanroom class ISO 14644-1, class ISO 7

Included in the delivery

(Catalogue HT accessories)

- 2x Centering bushing Ø7x3
- 4x Special screw M4 x 20/8
- 2x Shock absorber ASSD M6x0.5 - 4
- 2x Shock absorber ASED M6x0.5 - 1

Accessories

(Catalogue HT accessories)

- INI c10x28.5-Em-PNP-NO-M8x1

Alternative accessories

(Catalogue HT accessories)

- Steel stop ASS 04/25
- INI d4x25-Sn1.0-PNP-NO-M8x1
- INI c10x19.5-Em-PNP-NO-M8x1

Warranty: 24 months following commissioning, but a maximum of 27 months following delivery

Type	CS 12/30-SDH	CS 12/60-SDH	CS 12/90-SDH
A	102 mm	132 mm	162 mm
B	70 mm	100 mm	130 mm
C	4 x 15 mm	6 x 15 mm	8 x 15 mm
D	4 x 15 mm	6 x 15 mm	8 x 15 mm

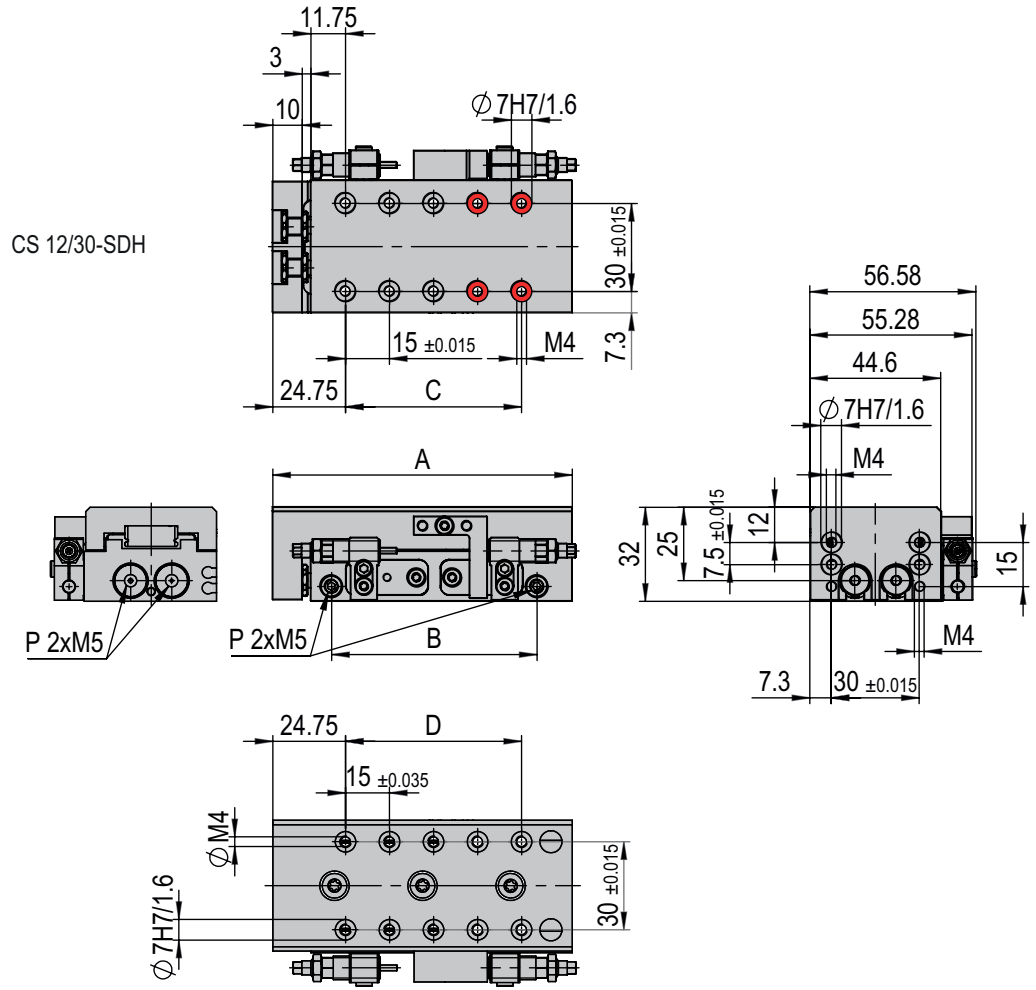
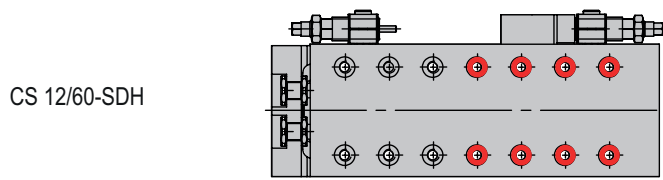
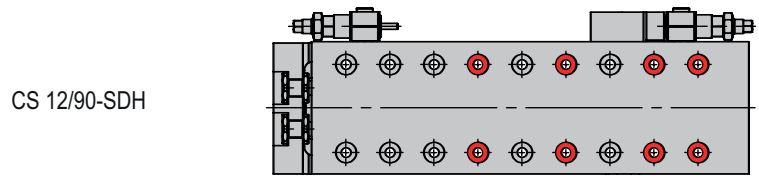

Bores can be screwed through

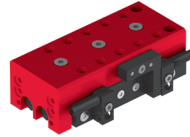

CS 12 -SDH	
Attachment grid	30 x 30 mm
Attachment thread	M4
Operating pressure	6 +/- 2 bar
Air connection P	M5
Cylinder Ø	2 x 10 mm
Retract piston force	71 N
Extend piston force	94 N
Operating temperature	0 - 50 °C
Storage temperature	0 - 50 °C
Humidity	< 90 %
Medium filtered compressed air	10 - 40 µm

Typ	CS 12/30-SDH	CS 12/60-SDH	CS 12/90-SDH
Bestellnummer	50509653	50509713	50509725
Stroke H	30 mm	60 mm	90 mm
Stroke limitation	2 x 25 mm	2 x 25 mm	2 x 25 mm
Net weight	0.5 kg	0.61 kg	0.73 kg
Moving weight	0.24 kg	0.3 kg	0.36 kg
Air consumption/cycle	0.038 NL	0.076 NL	0.114 NL
Noise level	64 dB (A)	64 dB (A)	64 dB (A)
Repeat accuracy	+/- 0.01 mm	+/- 0.01 mm	+/- 0.01 mm
Maximum speed	1 m/s	1 m/s	1 m/s
Minimum speed	0.02 m/s	0.02 m/s	0.02 m/s
Mounting position	✦	✦	✦

The technical data refers to a nominal pressure of 6 bar under Afag standard test conditions. The maximum payloads are listed in the payloads table in the slide loads section.
 Note: the CS 12/...-ED are supplied with an elastomer damper ASED
 The CS 12/...-SD are supplied with a hydraulic shock absorber ASSD
 The CS 12/...-SDH are supplied with a hydraulic shock absorber and with a stop sleeve
 The module can be operated with lubricated or dry air.
 Cleanroom class ISO 14644-1, class ISO 7

Included in the delivery

(Catalogue HT accessories)

- 2x Centering bushing Ø7x3
- 4x Special screw M4 x 20/8
- 2x Shock absorber ASSD M6x0.5 - 4
- 2x Shock absorber ASED M6x0.5 - 1

Accessories

(Catalogue HT accessories)

- INI c10x28.5-Em-PNP-NO-M8x1

Alternative accessories

(Catalogue HT accessories)

- Steel stop ASS 04/25
- INI d4x25-Sn1.0-PNP-NO-M8x1
- INI c10x19.5-Em-PNP-NO-M8x1

Warranty: 24 months following commissioning, but a maximum of 27 months following delivery

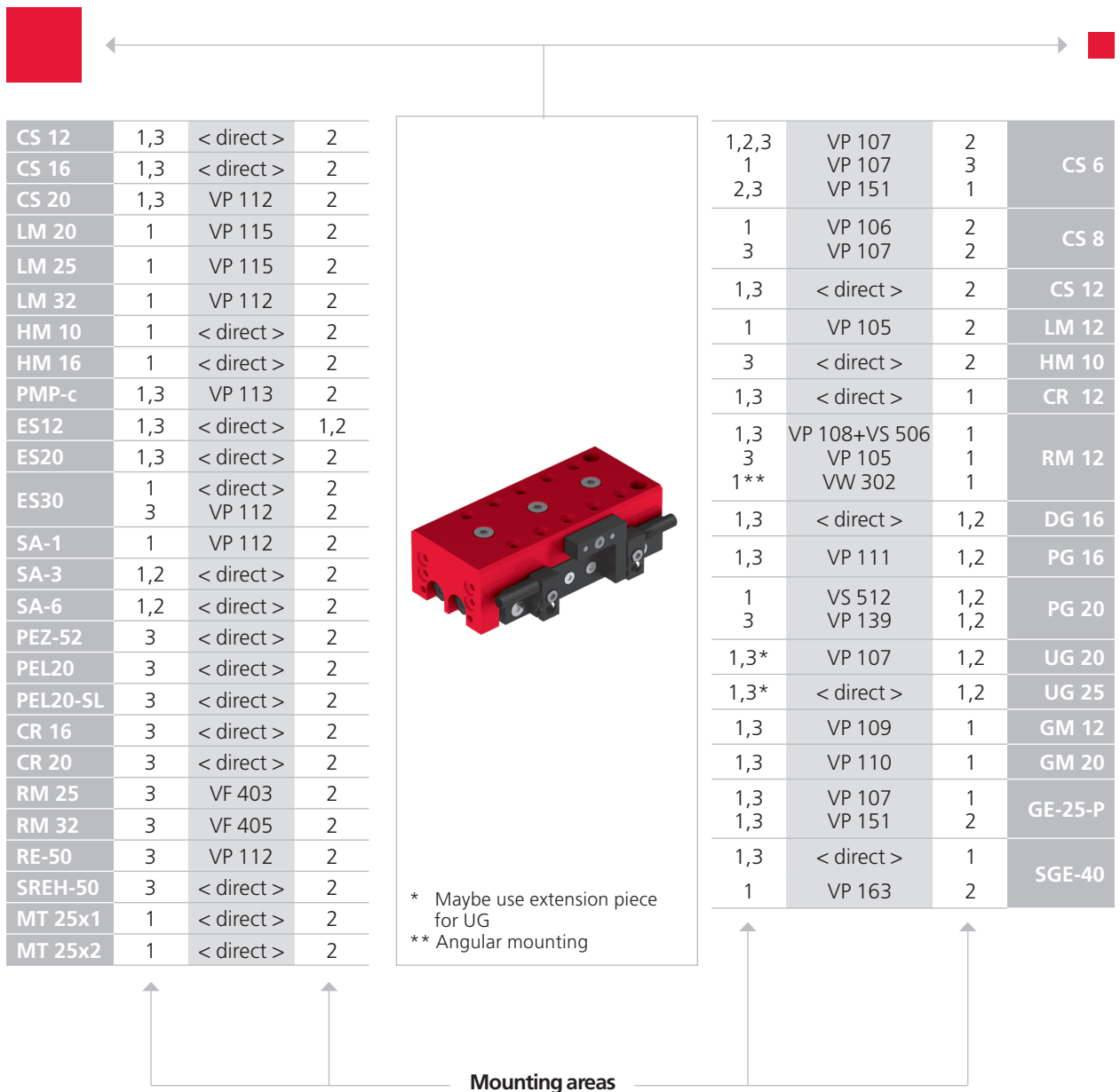

Note that there might be different mounting positions from one module to another one.
The required connection elements and the range of support columns are depicted in the catalogue HT accessories.

Type	CS 12/30-ED	CS 12/30-SD	CS 12/30-SDH	CS 12/60-ED	CS 12/60-SD	CS 12/60-SDH	CS 12/90-ED	CS 12/90-SD	CS 12/90-SDH
Max. torque M_x	13 Nm	13 Nm	13 Nm	13 Nm	13 Nm	13 Nm	13 Nm	13 Nm	13 Nm
Max. torque M_y	8 Nm	8 Nm	8 Nm	8 Nm	8 Nm	8 Nm	8 Nm	8 Nm	8 Nm
Max. torque M_z	8 Nm	8 Nm	8 Nm	8 Nm	8 Nm	8 Nm	8 Nm	8 Nm	8 Nm
Effective distance W_x	36.5 mm	36.5 mm	36.5 mm	36.5 mm	36.5 mm	36.5 mm	36.5 mm	36.5 mm	36.5 mm
Effective distance W_y	26 mm	26 mm	26 mm	26 mm	26 mm	26 mm	26 mm	26 mm	26 mm
Effective distance W_z	22 mm	22 mm	22 mm	22 mm	22 mm	22 mm	22 mm	22 mm	22 mm

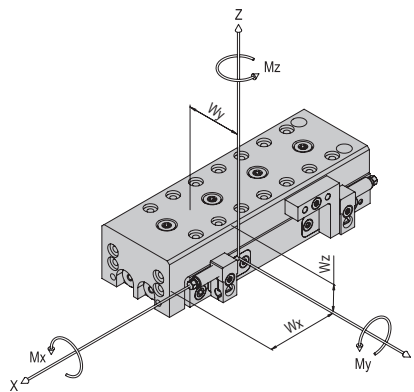

Maximum payload/type	CS 12/30-ED	CS 12/30-SD	CS 12/30-SDH	CS 12/60-ED	CS 12/60-SD	CS 12/60-SDH	CS 12/90-ED	CS 12/90-SD	CS 12/90-SDH
Installation position (horizontal) for mounting side 1	0.3 kg	0.7 kg	0.7 kg	0.3 kg	0.7 kg	0.7 kg	0.3 kg	0.7 kg	0.7 kg
Installation position (horizontal) for mounting side 3	0.3 kg	1.2 kg	1.2 kg	0.3 kg	1.2 kg	1.2 kg	0.3 kg	1.2 kg	1.2 kg
Installation position (vertical) for mounting side 1	0.3 kg	0.7 kg	0.7 kg	0.3 kg	0.7 kg	0.7 kg	0.3 kg	0.7 kg	0.7 kg
Installation position (vertical) for mounting side 3	0.3 kg	1.2 kg	1.2 kg	0.3 kg	1.2 kg	1.2 kg	0.3 kg	1.2 kg	1.2 kg

Assembly sides module mounting

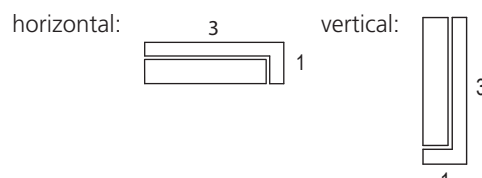

If the specified maximum payloads are exceeded, it must be ensured that the corresponding moments do not affect the service life of the module. In the event of critical applications, please contact Afag.

Operation time diagrams

CS 12/30-ED elastomer

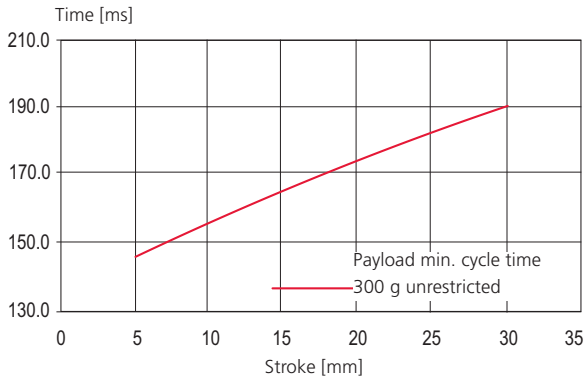

CS 12/30-SD hydraulic

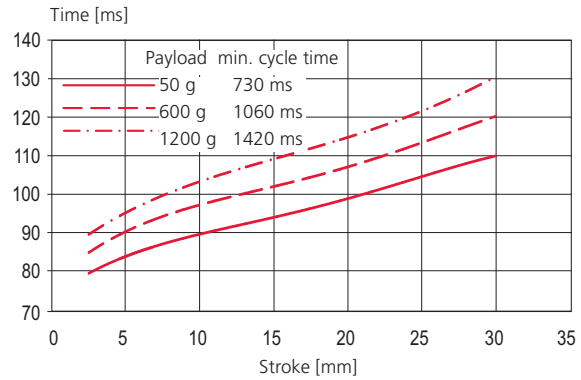

CS 12/60-ED elastomer

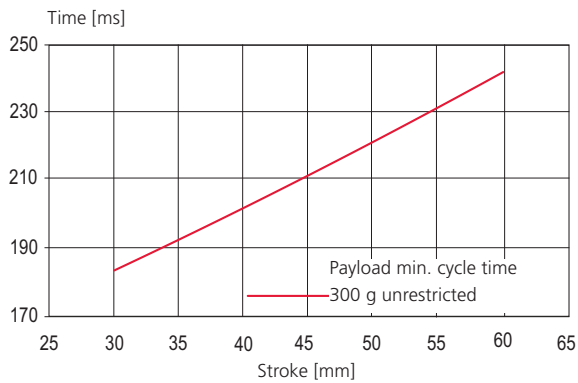

CS 12/60-SD hydraulic

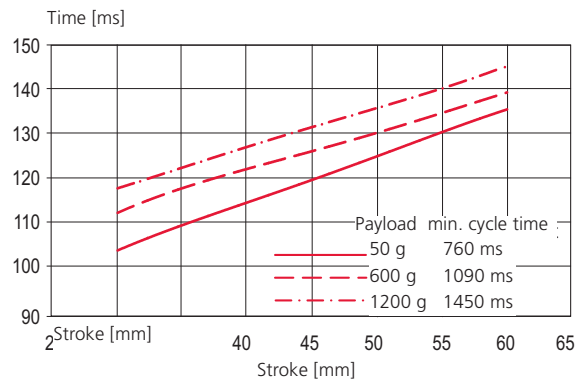

CS 12/90-ED elastomer

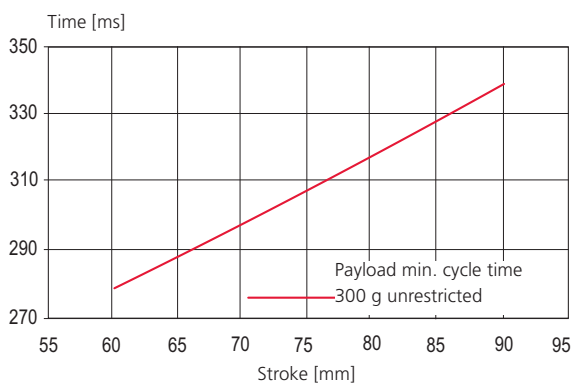

CS 12/90-SD hydraulic

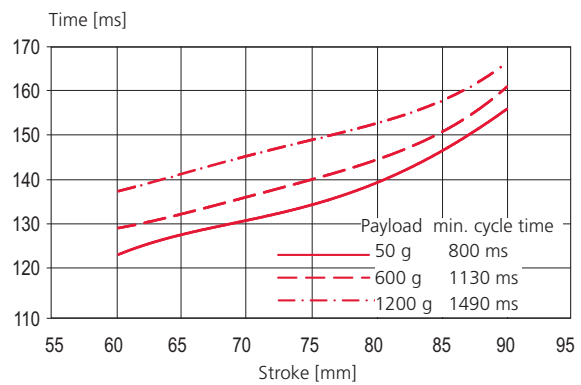

Compact slides CS

CS 16

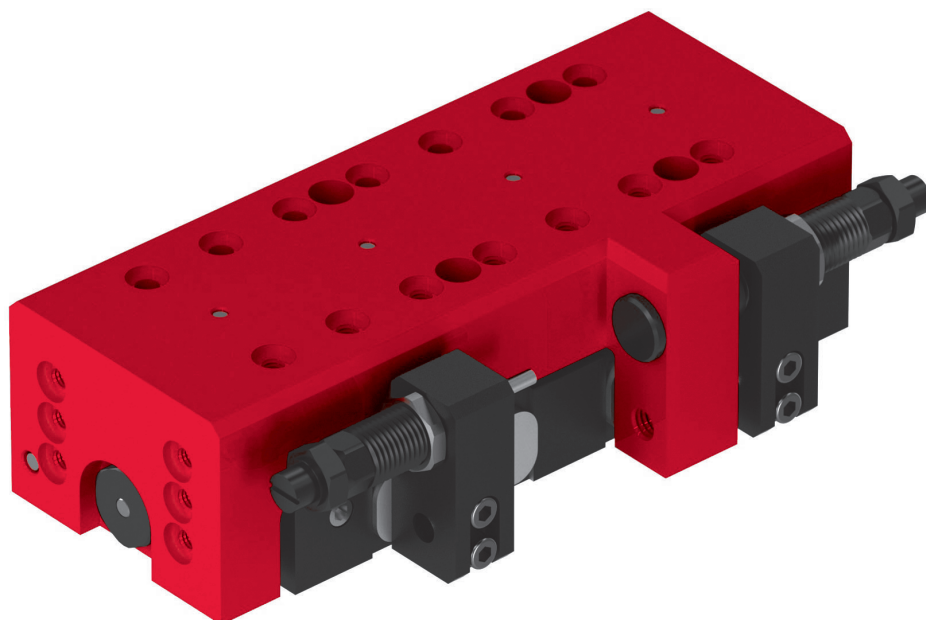

- Compact design
- Solid construction
- High rigidity
- Intermediate stop for 3rd Position

Type	CS 16/30	CS 16/60	CS 16/90	CS 16/120
A	6 x 15 mm	9 x 15 mm	11 x 15 mm	14 x 15 mm
B	93 mm	135.5 mm	167.5 mm	210 mm
C	130 mm	177 mm	209 mm	252 mm
D	6 x 15 mm	9 x 15 mm	11 x 15 mm	14 x 15 mm

CS 16/120

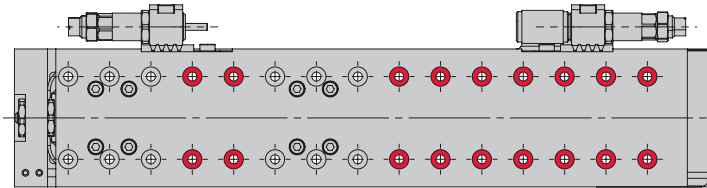

CS 16/90

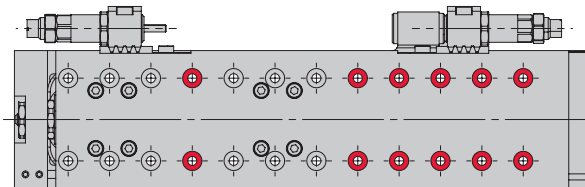

CS 16/60

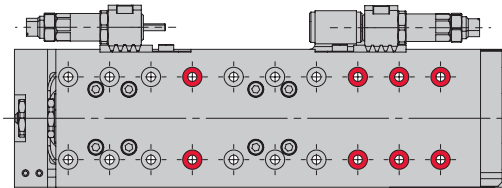

CS 16/30

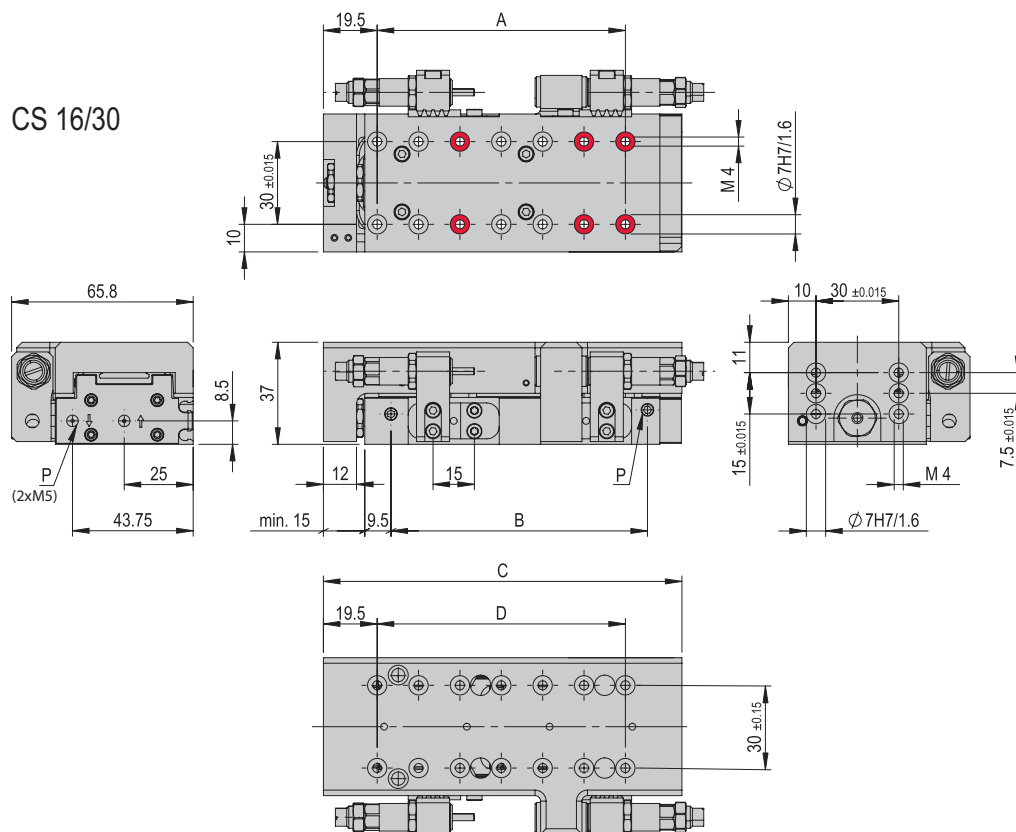

 Bores can be screwed through

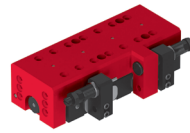

CS 16	
Attachment grid	30 x 30 mm
Attachment thread	M4
Operating pressure	6 +/- 2 bar
Air connection P	M5
Cylinder Ø	16 mm
Retract piston force	103 N
Extend piston force	120 N
Operating temperature	0 - 50 °C
Storage temperature	0 - 50 °C
Humidity	< 90 %
Medium filtered compressed air	10 - 40 µm

Type	CS 16/30	CS 16/60	CS 16/90	CS 16/120
Order number	50167742	50154069	50154070	50154071
Stroke H	30 mm	60 mm	90 mm	120 mm
Stroke limitation	2 x 30 mm	2 x 30 mm	2 x 30 mm	2 x 30 mm
Net weight	0.74 kg	0.98 kg	1.2 kg	1.27 kg
Moving weight	0.34 kg	0.48 kg	0.564 kg	0.671 kg
Air consumption/cycle	0.0554 NL	0.1109 NL	0.1664 NL	0.2218 NL
Noise level	64 dB (A)	64 dB (A)	64 dB (A)	64 dB (A)
Repeat accuracy	+/- 0.01 mm	+/- 0.01 mm	+/- 0.01 mm	+/- 0.01 mm
Maximum speed	1 m/s	1 m/s	1 m/s	1 m/s
Minimum speed	0.1 m/s	0.1 m/s	0.1 m/s	0.1 m/s
Mounting position	✦	✦	✦	✦

The technical data refers to a nominal pressure of 6 bar under Afag standard test conditions. The maximum payloads are listed in the payloads table in the slide loads section. The module can be operated with lubricated or dry air.
Cleanroom class ISO 14644-1, class ISO 7

Included in the delivery (Catalogue HT accessories)

- 2x Centering bushing Ø7x3
- 4x Special screw M4 x 20/8
- 2x Stop sleeve ASH M10x1 -1
- 2x Shock absorber SD M8x1 -4

Accessories

- Installation set proximity switch CS 16/CS 20 [p. 48]
 - Intermediate stop ZA-CS 16 [p. 46]
- (Catalogue HT accessories)
- INI c10x28.5-Em-PNP-NO-M8x1

Alternative accessories

- (Catalogue HT accessories)
- INI c10x19.5-Em-PNP-NO-M8x1
 - INI d4x25-Sn1.0-PNP-NO-M8x1

Warranty: 24 months following commissioning, but a maximum of 27 months following delivery

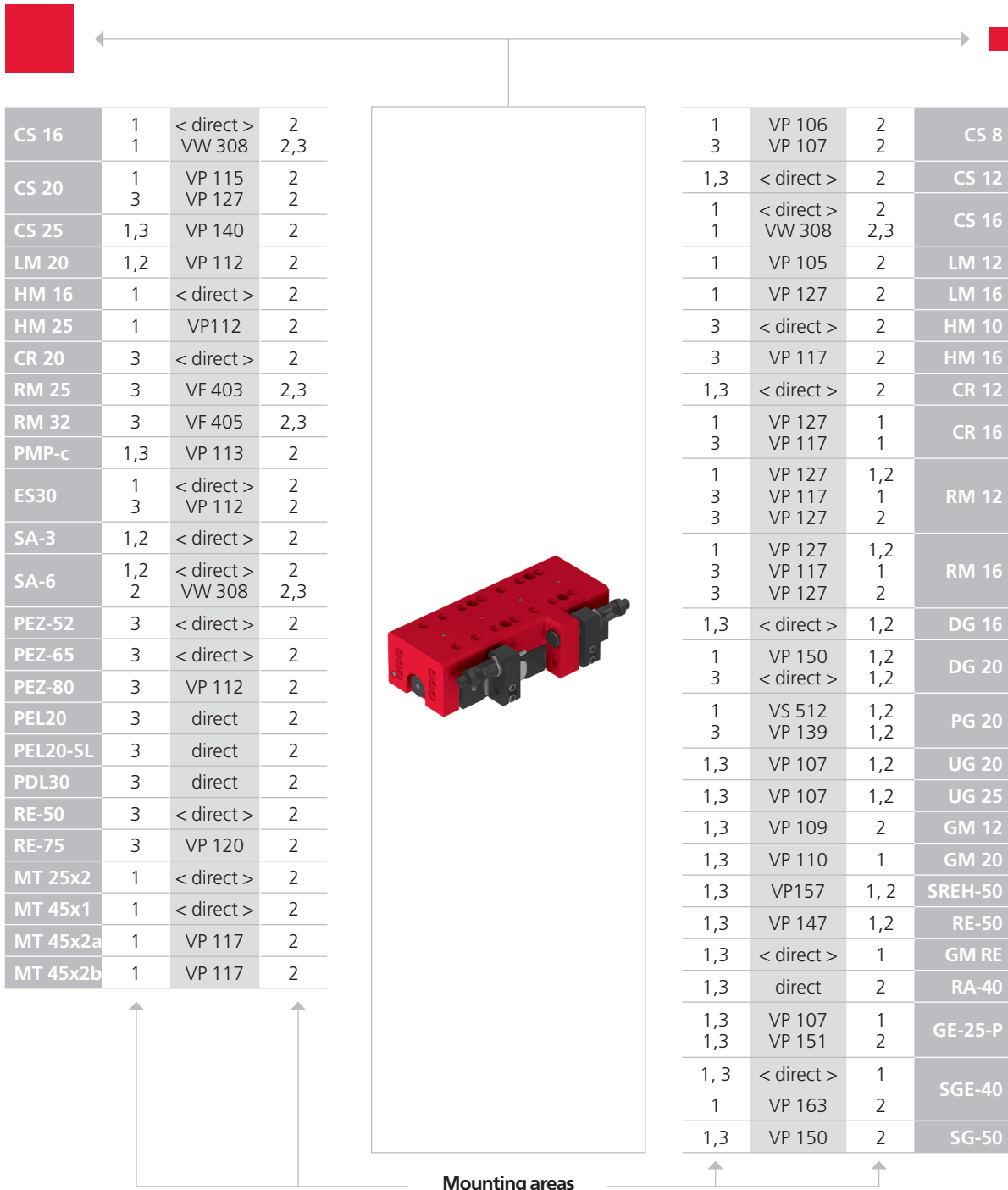

CS 16	1 1	< direct > VW 308	2 2,3
CS 20	1 3	VP 115 VP 127	2 2
CS 25	1,3	VP 140	2
LM 20	1,2	VP 112	2
HM 16	1	< direct >	2
HM 25	1	VP112	2
CR 20	3	< direct >	2
RM 25	3	VF 403	2,3
RM 32	3	VF 405	2,3
PMP-c	1,3	VP 113	2
ES30	1 3	< direct > VP 112	2 2
SA-3	1,2	< direct >	2
SA-6	1,2 2	< direct > VW 308	2 2,3
PEZ-52	3	< direct >	2
PEZ-65	3	< direct >	2
PEZ-80	3	VP 112	2
PEL20	3	direct	2
PEL20-SL	3	direct	2
PDL30	3	direct	2
RE-50	3	< direct >	2
RE-75	3	VP 120	2
MT 25x2	1	< direct >	2
MT 45x1	1	< direct >	2
MT 45x2a	1	VP 117	2
MT 45x2b	1	VP 117	2

1 3	VP 106 VP 107	2 2	CS 8
1,3	< direct >	2	CS 12
1 1	< direct > VW 308	2 2,3	CS 16
1	VP 105	2	LM 12
1	VP 127	2	LM 16
3	< direct >	2	HM 10
3	VP 117	2	HM 16
1,3	< direct >	2	CR 12
1 3	VP 127 VP 117	1 1	CR 16
1 3 3	VP 127 VP 117 VP 127	1,2 1 2	RM 12
1 3 3	VP 127 VP 117 VP 127	1,2 1 2	RM 16
1,3	< direct >	1,2	DG 16
1 3	VP 150 < direct >	1,2 1,2	DG 20
1 3	VS 512 VP 139	1,2 1,2	PG 20
1,3	VP 107	1,2	UG 20
1,3	VP 107	1,2	UG 25
1,3	VP 109	2	GM 12
1,3	VP 110	1	GM 20
1,3	VP157	1, 2	SREH-50
1,3	VP 147	1,2	RE-50
1,3	< direct >	1	GM RE
1,3	direct	2	RA-40
1,3 1,3	VP 107 VP 151	1 2	GE-25-P
1, 3	< direct >	1	SGE-40
1	VP 163	2	SG-50
1,3	VP 150	2	SG-50

Mounting areas

CS, ES 	LM 	HM 	SA 	UG, GM, SG, DG, PG, GE, SGE
PMP, PMP-c 	PEZ, PDZ 	PEL, PDL 	RM, RE 	CR, RM 32, RE, SREH, RA

Note that there might be different mounting positions from one module to another one. The required connection elements and the range of support columns are depicted in the catalogue HT accessories.

Type	CS 16/30	CS 16/60	CS 16/90	CS 16/120
Max. torque M_x	10 Nm	14 Nm	14 Nm	14 Nm
Max. torque M_y	18 Nm	32 Nm	33 Nm	39 Nm
Max. torque M_z	25 Nm	44 Nm	46 Nm	56 Nm
Effective distance W_x	51 mm	65 mm	65 mm	72 mm
Effective distance W_y	33 mm	33 mm	33 mm	33 mm
Effective distance W_z	11 mm	11 mm	11 mm	11 mm

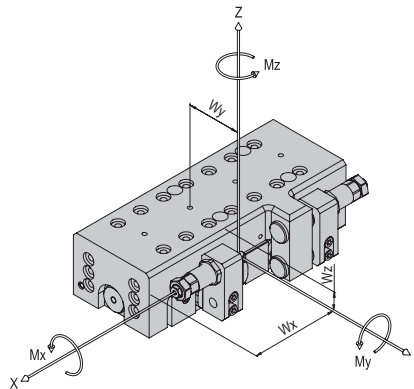

Maximum payload/type	CS 16/30	CS 16/60	CS 16/90	CS 16/120
Installation position (horizontal) for mounting side 1	1.5 kg	2 kg	2 kg	2 kg
Installation position (horizontal) for mounting side 3	2 kg	3 kg	3 kg	3 kg
Installation position (vertical) for mounting side 1	1.5 kg	2 kg	2 kg	2 kg
Installation position (vertical) for mounting side 3	2 kg	3 kg	3 kg	3 kg

Assembly sides
module mounting

horizontal:

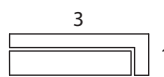

vertical:

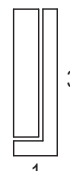

If the specified maximum payloads are exceeded, it must be ensured that the corresponding moments do not affect the service life of the module. In the event of critical applications, please contact Afag.

Operation time diagrams

CS 16/30

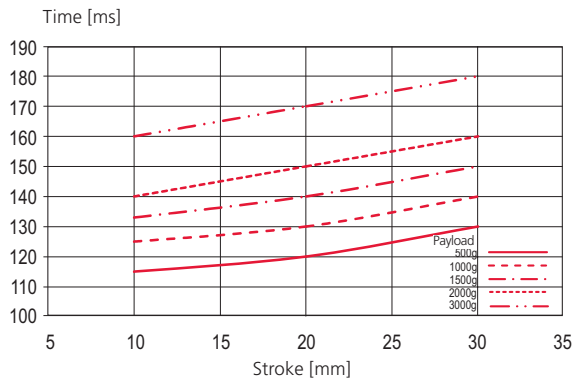

CS 16/60

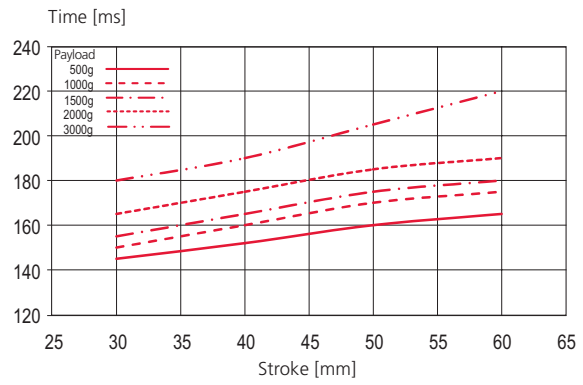

CS 16/90

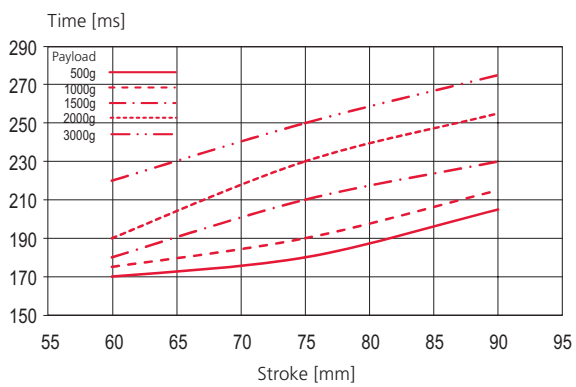

CS 16/120

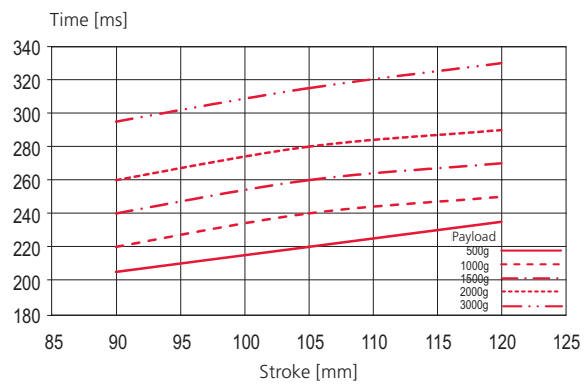

Compact slides CS

CS 20

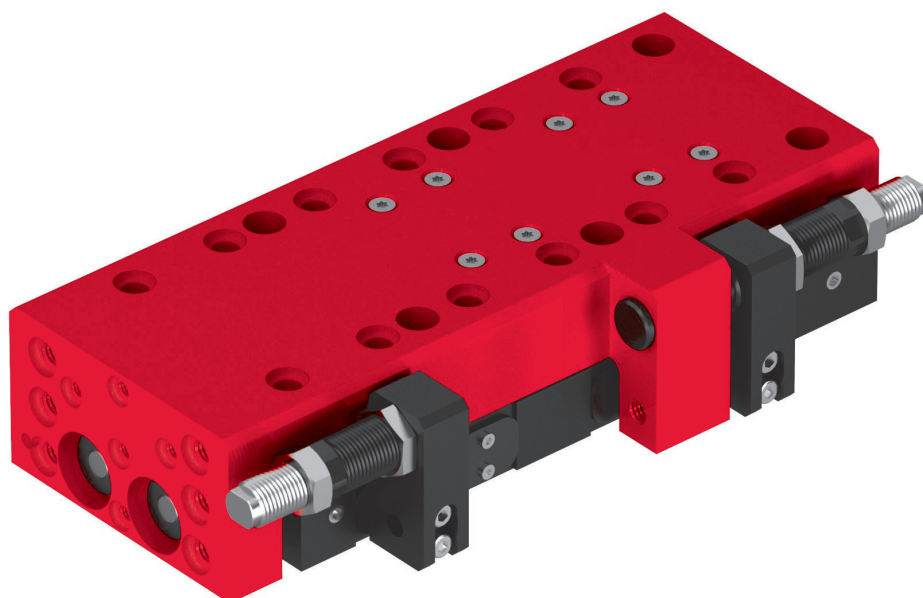

- Compact design
- Solid construction
- High rigidity
- Intermediate stop for 3rd Position

Type	CS 20/50	CS 20/100	CS 20/150
A	5 x 24 mm	8 x 24 mm	10 x 24 mm
B	134.5 mm	194.5 mm	254.5 mm
C	175 mm	235 mm	295 mm
D	5 x 24 mm	8 x 24 mm	10 x 24 mm
E	Top slide	Top slide	Top slide
F	Front	Front	Front

CS 20/150

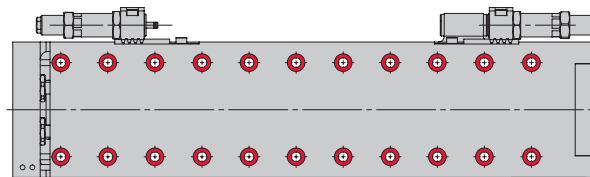

CS 20/100

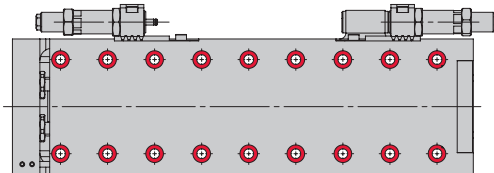

CS 20/50

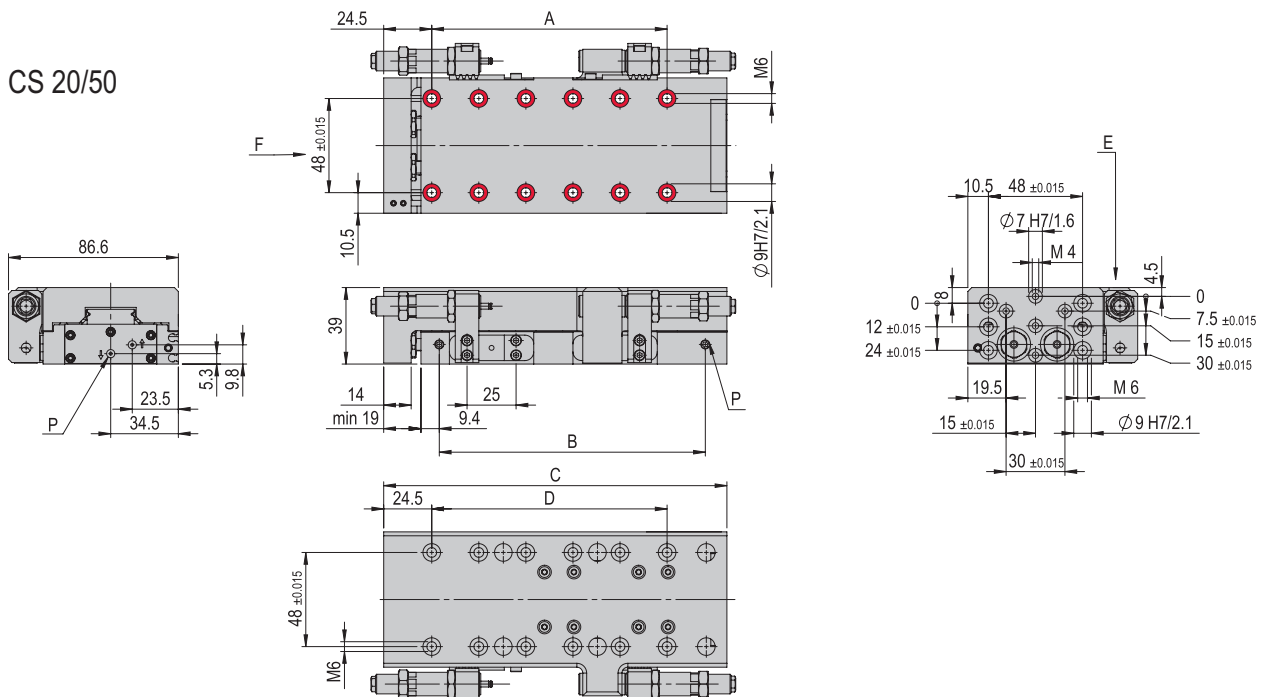

Bores can be screwed through

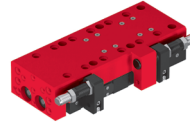

CS 20	
Attachment grid	48 x 48 mm
Attachment thread	M6
Operating pressure	6 +/- 2 bar
Air connection P	M5
Cylinder Ø	2 x 16 mm
Retract piston force	207 N
Extend piston force	241 N
Operating temperature	0 - 50 °C
Storage temperature	0 - 50 °C
Humidity	< 90 %
Medium filtered compressed air	10 - 40 µm

Type	CS 20/50	CS 20/100	CS 20/150
Order number	50100711	50100712	50100713
Stroke H	50 mm	100 mm	150 mm
Stroke limitation	2 x 25 mm	2 x 25 mm	2 x 25 mm
Net weight	1.5 kg	1.8 kg	2.2 kg
Moving weight	0.8 kg	1 kg	1.2 kg
Air consumption/cycle	0.1718 NL	0.3436 NL	0.5154 NL
Noise level	64 dB (A)	64 dB (A)	64 dB (A)
Repeat accuracy	+/- 0.01 mm	+/- 0.01 mm	+/- 0.01 mm
Maximum speed	1 m/s	1 m/s	1 m/s
Minimum speed	0.02 m/s	0.02 m/s	0.02 m/s
Mounting position	↕	↕	↕

The technical data refers to a nominal pressure of 6 bar under Afag standard test conditions. The maximum payloads are listed in the payloads table in the slide loads section. The module can be operated with lubricated or dry air. Cleanroom class ISO 14644-1, class ISO 7

Included in the delivery (Catalogue HT accessories)

- 2x Centering bushing Ø9x4
- 4x Special screw M6 x 25/9
- 2x Stop sleeve ASH M12x1 -1
- 2x Shock absorber SD M10x1 -5

Accessories

- Intermediate stop ZA-CS 20 [p. 47]
 - Installation set proximity switch CS 16/CS 20 [p. 48]
- (Catalogue HT accessories)
- INI c10x28.5-Em-PNP-NO-M8x1

Alternative accessories

- (Catalogue HT accessories)
- INI d4x25-Sn1.0-PNP-NO-M8x1

Warranty: 24 months following commissioning, but a maximum of 27 months following delivery

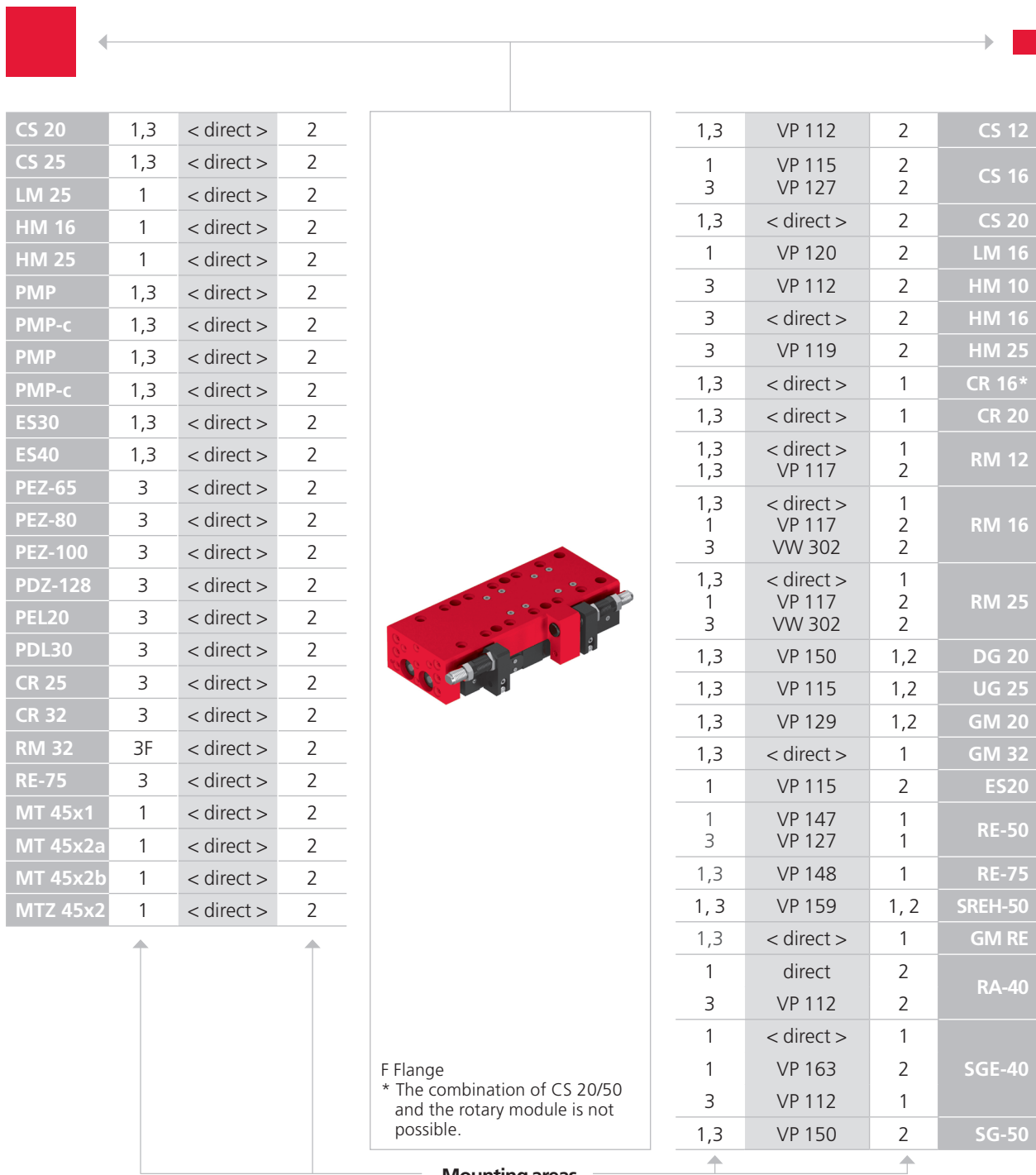

CS 20	1,3	< direct >	2
CS 25	1,3	< direct >	2
LM 25	1	< direct >	2
HM 16	1	< direct >	2
HM 25	1	< direct >	2
PMP	1,3	< direct >	2
PMP-c	1,3	< direct >	2
PMP	1,3	< direct >	2
PMP-c	1,3	< direct >	2
ES30	1,3	< direct >	2
ES40	1,3	< direct >	2
PEZ-65	3	< direct >	2
PEZ-80	3	< direct >	2
PEZ-100	3	< direct >	2
PDZ-128	3	< direct >	2
PEL20	3	< direct >	2
PDL30	3	< direct >	2
CR 25	3	< direct >	2
CR 32	3	< direct >	2
RM 32	3F	< direct >	2
RE-75	3	< direct >	2
MT 45x1	1	< direct >	2
MT 45x2a	1	< direct >	2
MT 45x2b	1	< direct >	2
MTZ 45x2	1	< direct >	2

1,3	VP 112	2	CS 12
1	VP 115	2	CS 16
3	VP 127	2	CS 16
1,3	< direct >	2	CS 20
1	VP 120	2	LM 16
3	VP 112	2	HM 10
3	< direct >	2	HM 16
3	VP 119	2	HM 25
1,3	< direct >	1	CR 16*
1,3	< direct >	1	CR 20
1,3	< direct >	1	RM 12
1,3	VP 117	2	RM 12
1,3	< direct >	1	RM 16
1	VP 117	2	RM 16
3	VW 302	2	RM 16
1,3	< direct >	1	RM 25
1	VP 117	2	RM 25
3	VW 302	2	RM 25
1,3	VP 150	1,2	DG 20
1,3	VP 115	1,2	UG 25
1,3	VP 129	1,2	GM 20
1,3	< direct >	1	GM 32
1	VP 115	2	ES20
1	VP 147	1	RE-50
3	VP 127	1	RE-50
1,3	VP 148	1	RE-75
1,3	VP 159	1, 2	SREH-50
1,3	< direct >	1	GM RE
1	direct	2	RA-40
3	VP 112	2	RA-40
1	< direct >	1	SGE-40
1	VP 163	2	SGE-40
3	VP 112	1	SGE-40
1,3	VP 150	2	SG-50

Mounting areas

CS, ES 	LM 	HM 	SA 	UG, GM, SG, DG, PG, GE, SGE
PMP, PMP-c 	PEZ, PDZ 	PEL, PDL 	RM, RE 	CR, RM 32, RE, SREH, RA

Note that there might be different mounting positions from one module to another one.
The required connection elements and the range of pedestals are depicted in the catalogue HT accessories.

Type	CS 20/50	CS 20/100	CS 20/150
Max. torque M_x	57 Nm	57 Nm	57 Nm
Max. torque M_y	50 Nm	57 Nm	63 Nm
Max. torque M_z	50 Nm	57 Nm	63 Nm
Effective distance W_x	106 mm	163 mm	217 mm
Effective distance W_y	43 mm	43 mm	43 mm
Effective distance W_z	14 mm	14 mm	14 mm

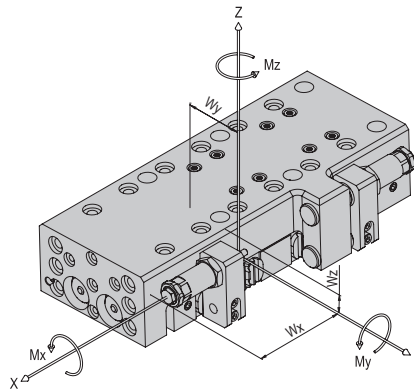

Maximum payload/type	CS 20/50	CS 20/100	CS 20/150
Installation position (horizontal) for mounting side 1	4 kg	4 kg	4 kg
Installation position (horizontal) for mounting side 3	5 kg	5 kg	5 kg
Installation position (vertical) for mounting side 1	4 kg	4 kg	4 kg
Installation position (vertical) for mounting side 3	5 kg	5 kg	5 kg

Assembly sides
module mounting

horizontal:

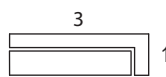

vertical:

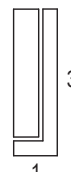

If the specified maximum payloads are exceeded, it must be ensured that the corresponding moments do not affect the service life of the module. In the event of critical applications, please contact Afag.

Operation time diagrams

CS 20/50

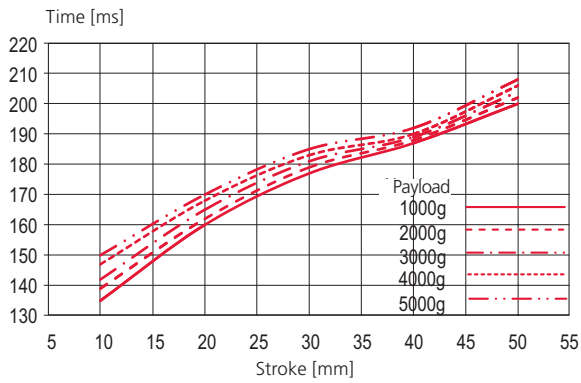

CS 20/100

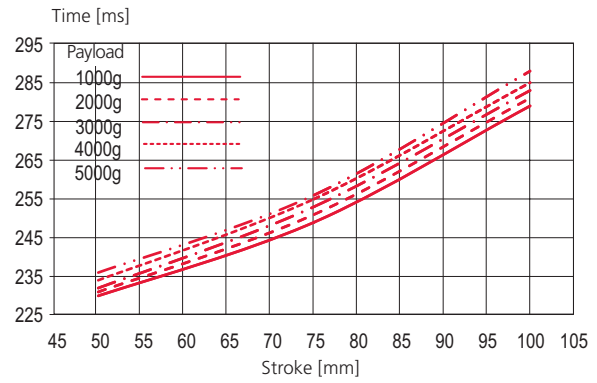

CS 20/150

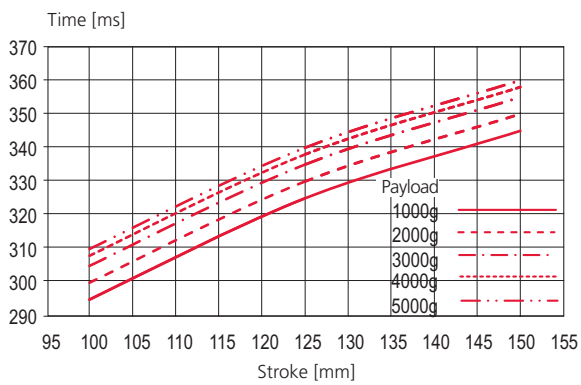

Compact slides CS

CS 25

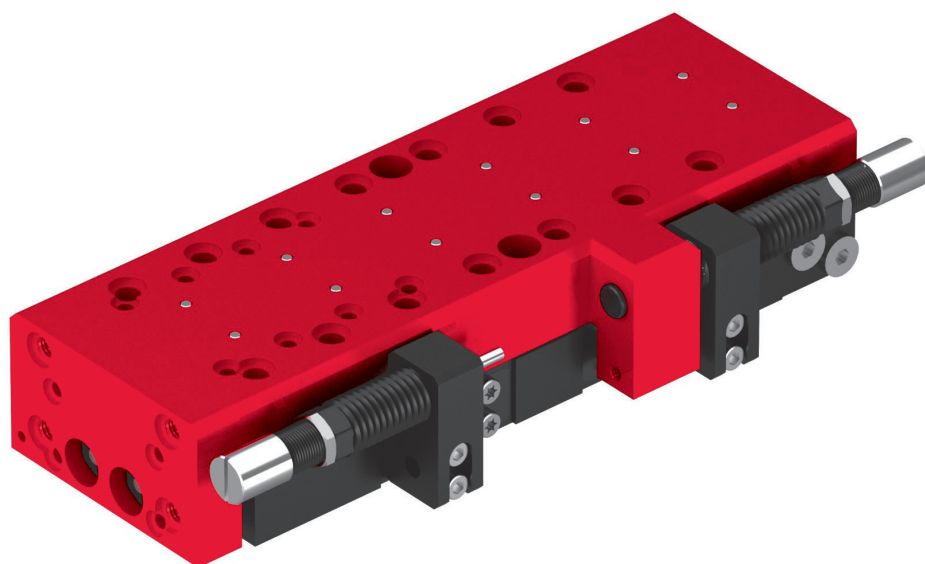

- Compact design
- Solid construction
- High rigidity
- Intermediate stop for 3rd Position

Type	CS 25/60	CS 25/120	CS 25/180	CS 25/240
A	265 mm	325 mm	415 mm	475 mm
B	6 x 30 mm	8 x 30 mm	11 x 30 mm	13 x 30 mm
C	6 x 30 mm	8 x 30 mm	11 x 30 mm	13 x 30 mm

CS 25/240

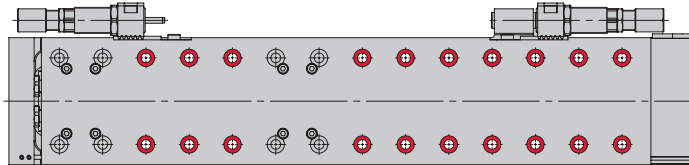

CS 25/180

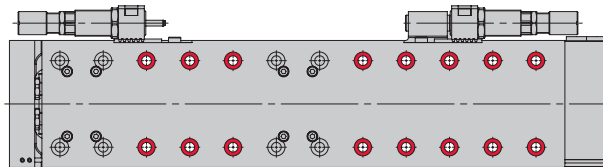

CS 25/120

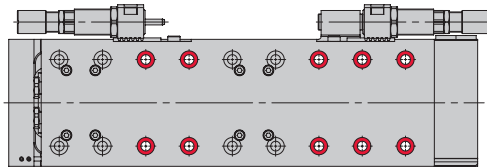

CS 25/60

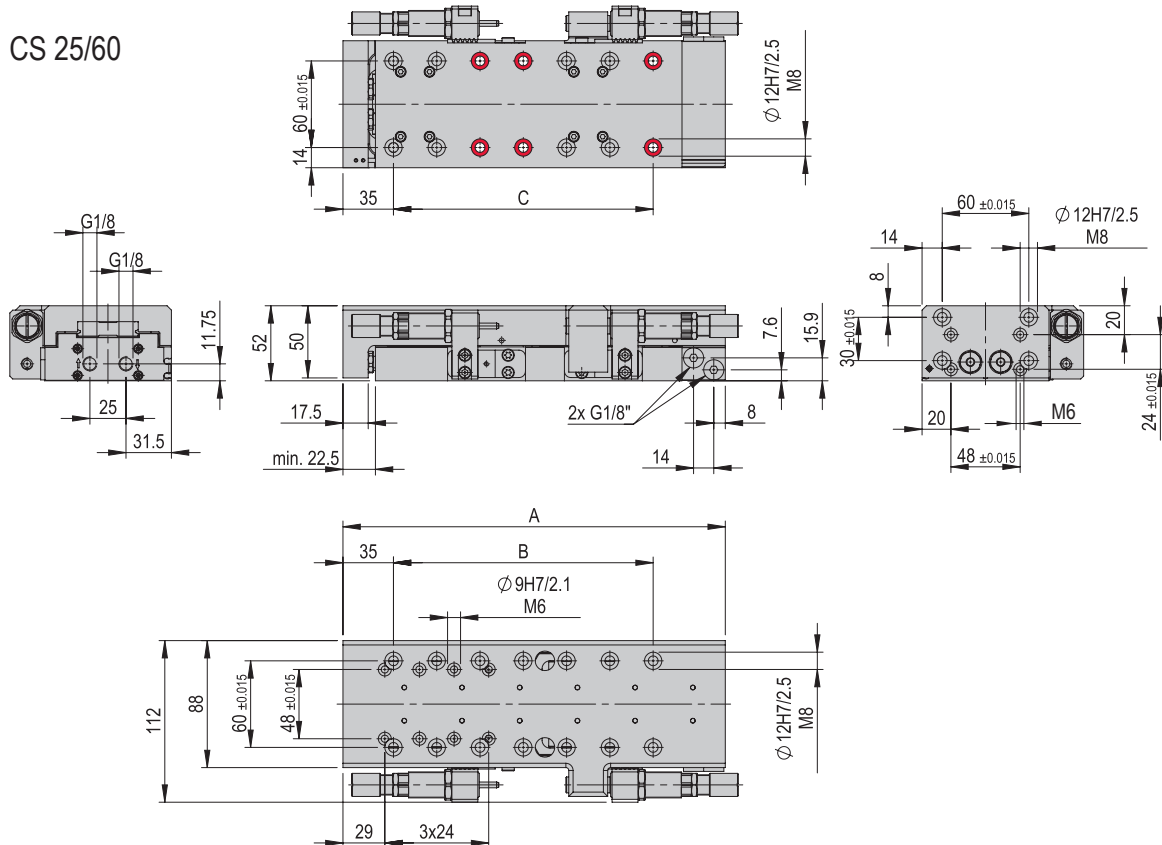

Bores can be screwed through

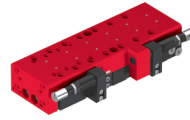

CS 25	
Attachment grid	60 x 60 mm
Attachment grid alternative	48 x 48 mm
Attachment thread	M8
Attachment thread alternative	M6
Operating pressure	6 +/- 2 bar
Air connection P	G1/8 "
Cylinder Ø	2 x 18 mm
Retract piston force	245 N
Extend piston force	305 N
Operating temperature	0 - 50 °C
Storage temperature	0 - 50 °C
Humidity	< 90 %
Medium filtered compressed air	10 - 40 µm

Type	CS 25/60	CS 25/120	CS 25/180	CS 25/240
Order number	50224806	50224807	50224808	50224809
Stroke H	60 mm	120 mm	180 mm	240 mm
Stroke limitation	2 x 30 mm	2 x 30 mm	2 x 30 mm	2 x 30 mm
Net weight	3.935 kg	4.58 kg	5.62 kg	6.26 kg
Moving weight	1.9 kg	2.3 kg	3 kg	3.4 kg
Air consumption/cycle	0.253 NL	0.503 NL	0.759 NL	1.012 NL
Noise level	64 dB (A)	64 dB (A)	64 dB (A)	64 dB (A)
Repeat accuracy	+/- 0.01 mm	+/- 0.01 mm	+/- 0.01 mm	+/- 0.01 mm
Maximum speed	1 m/s	1 m/s	1 m/s	1 m/s
Minimum speed	0.5 m/s	0.5 m/s	0.5 m/s	0.5 m/s
Mounting position	↕	↕	↕	↕

The technical data refers to a nominal pressure of 6 bar under Afag standard test conditions. The maximum payloads are listed in the payloads table in the slide loads section. The module can be operated with lubricated or dry air. Cleanroom class ISO 14644-1, class ISO 7

Included in the delivery

- (Catalogue HT accessories)
- 2x Centering bushing Ø12x4.8
 - 4x Special screw M8 x 35/15
 - 2x Stop sleeve ASH M18x1 -1
 - 2x Shock absorber SD M14x1 -2

Accessories

- Intermediate stop ZA-CS 25 [p. 48]
- Installation set proximity switch CS 25 [p. 48]
- (Catalogue HT accessories)
- INI c10x28.5-Em-PNP-NO-M8x1

Alternative accessories

- (Catalogue HT accessories)
- INI d6.5x35-Sn1.5-PNP-NO-M8x1

Warranty: 24 months following commissioning, but a maximum of 27 months following delivery

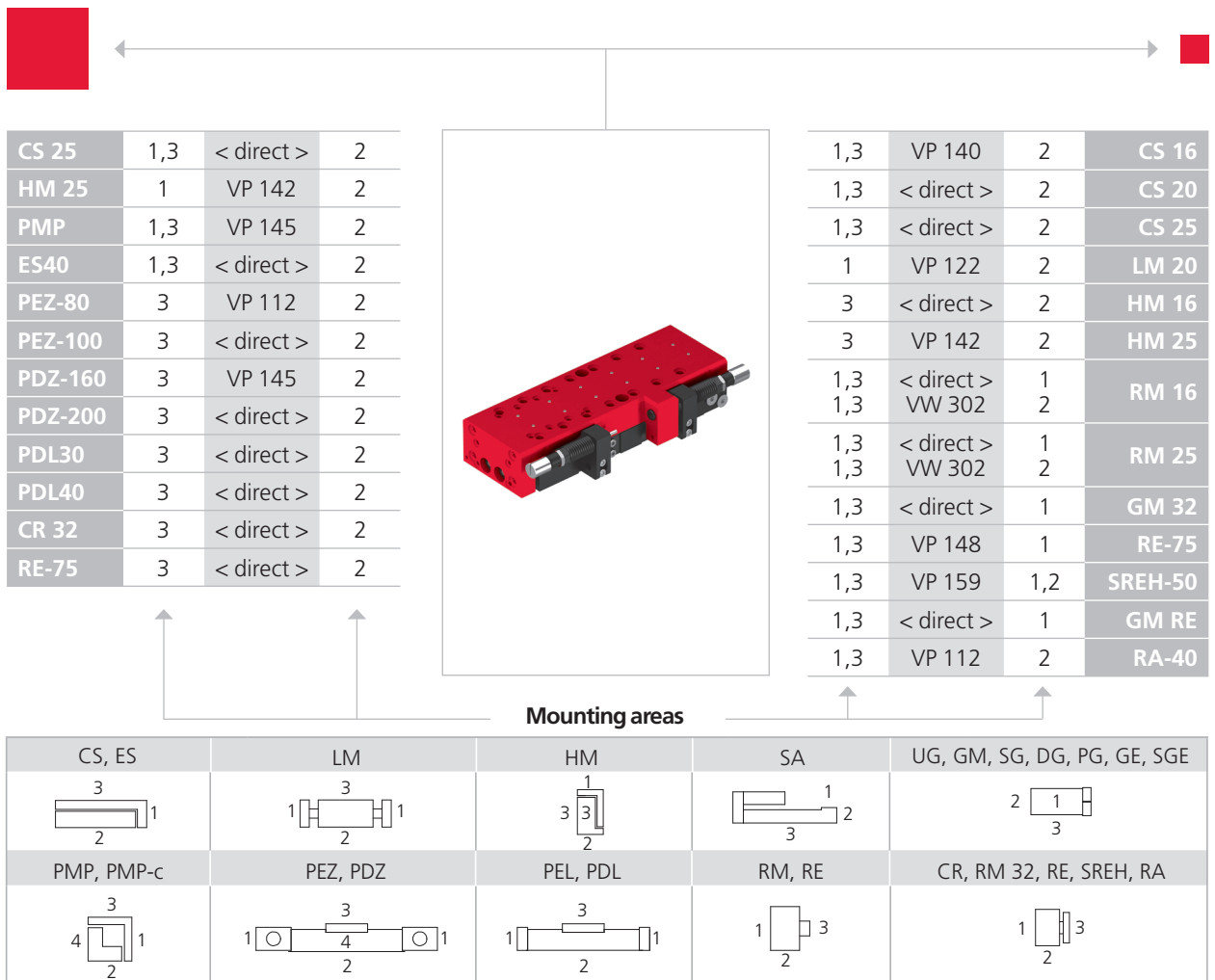

Note that there might be different mounting positions from one module to another one.

The required connection elements and the range of support columns are depicted in the catalogue HT accessories.

Type	CS 25/60	CS 25/120	CS 25/180	CS 25/240
Max. torque Mx	84 Nm	84 Nm	84 Nm	84 Nm
Max. torque My	133 Nm	133 Nm	140 Nm	140 Nm
Max. torque Mz	112 Nm	112 Nm	120 Nm	120 Nm
Effective distance Wx	95 mm	95 mm	95 mm	95 mm
Effective distance Wy	56 mm	56 mm	56 mm	56 mm
Effective distance Wz	14 mm	14 mm	14 mm	14 mm

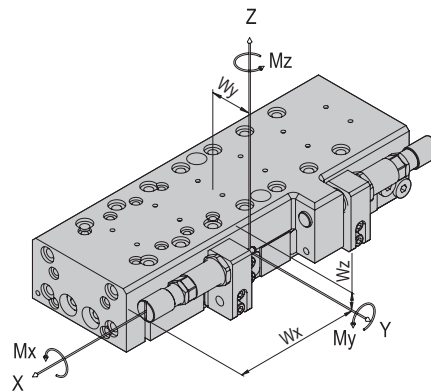

Maximum payload/type	CS 25/60	CS 25/120	CS 25/180	CS 25/240
Installation position (horizontal) for mounting side 1	5 kg	5 kg	5 kg	5 kg
Installation position (horizontal) for mounting side 3	7.5 kg	7.5 kg	7.5 kg	7.5 kg
Installation position (vertical) for mounting side 1	5 kg	5 kg	5 kg	5 kg
Installation position (vertical) for mounting side 3	7.5 kg	7.5 kg	7.5 kg	7.5 kg

Assembly sides
module mounting

horizontal:

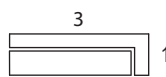

vertical:

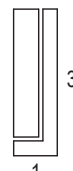

If the specified maximum payloads are exceeded, it must be ensured that the corresponding moments do not affect the service life of the module. In the event of critical applications, please contact Afag.

Operation time diagrams

CS 25/60

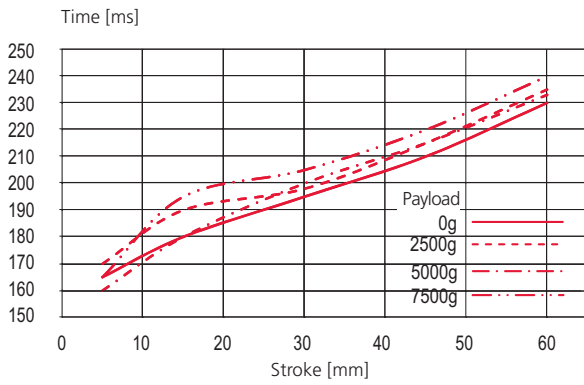

CS 25/120

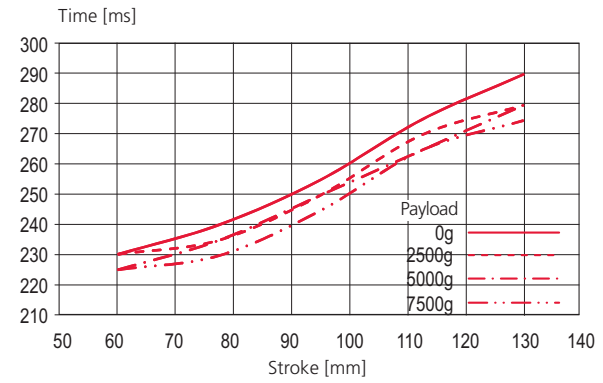

CS 25/180

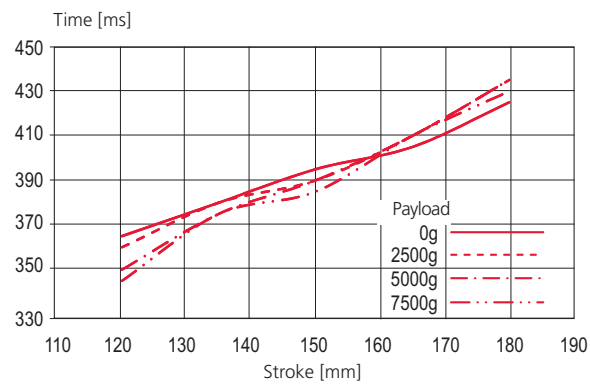

CS 25/240

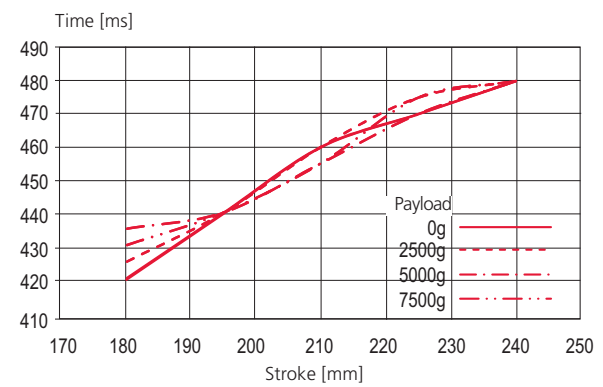

Accessories CS

Intermediate stop ZA-CS 16	ZA-CS 16
Order number	50205052
Net weight	0.42 kg
P	M5

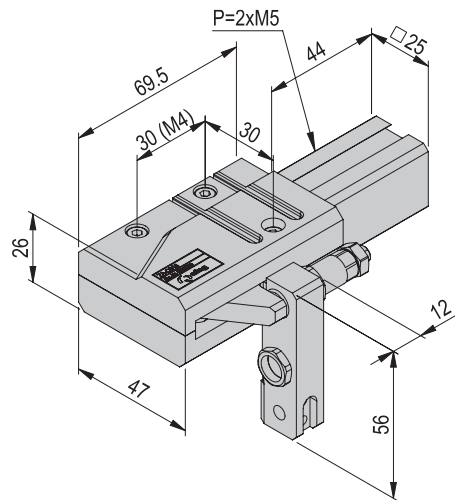

- Included in the delivery**
(Catalogue HT accessories)
- 3x Centering bushing Ø7x3
 - 3x Mounting screw M4x25
 - 1x Stop sleeve ASH M10x1 -1
 - 1x Shock absorber SD M8x1 -4

- Accessories**
(Catalogue HT accessories)
- INI c10x28.5-Em-PNP-NO-M8x1

Intermediate stop ZA-CS 20	ZA-CS 20
Order number	50205054
Net weight	0.411 kg
P	M5

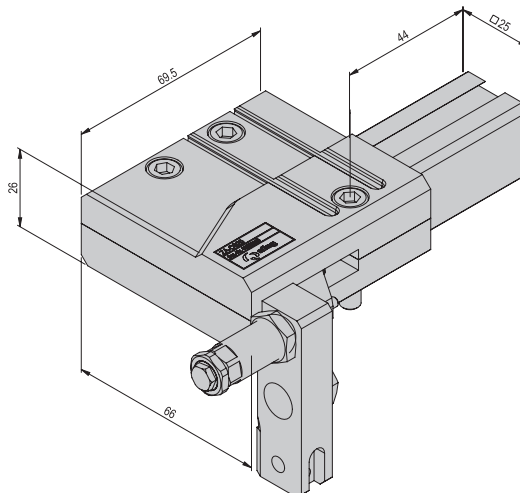

- Included in the delivery**
(Catalogue HT accessories)
- 3x Centering bushing Ø9x4
 - 3x Mounting screw M6x30
 - 1x Stop sleeve ASH M12x1 -1
 - 1x Shock absorber SD M10x1 -5

- Accessories**
(Catalogue HT accessories)
- INI d4x25-Sn1.0-PNP-NO-M8x1
 - INI c10x28.5-Em-PNP-NO-M8x1

Accessories CS

Intermediate stop ZA-CS 25	ZA-CS 25
Order number	50224670
Net weight	0.816 kg
P	M5

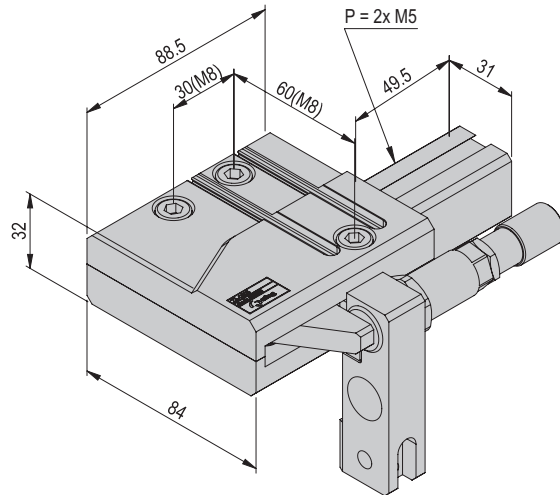

Included in the delivery

(Catalogue HT accessories)

- 3x Centering bushing $\varnothing 12 \times 4.8$
- 3x Mounting screw M8x35
- 1x Stop sleeve ASH M18x1 -1
- 1x Shock absorber SD M14x1 -2

Accessories

(Catalogue HT accessories)

- INI d4x25-Sn1.0-PNP-NO-M8x1
- INI c10x28.5-Em-PNP-NO-M8x1

SDH-fastening CS 8

Order number	50568020
Net weight	0.01 kg

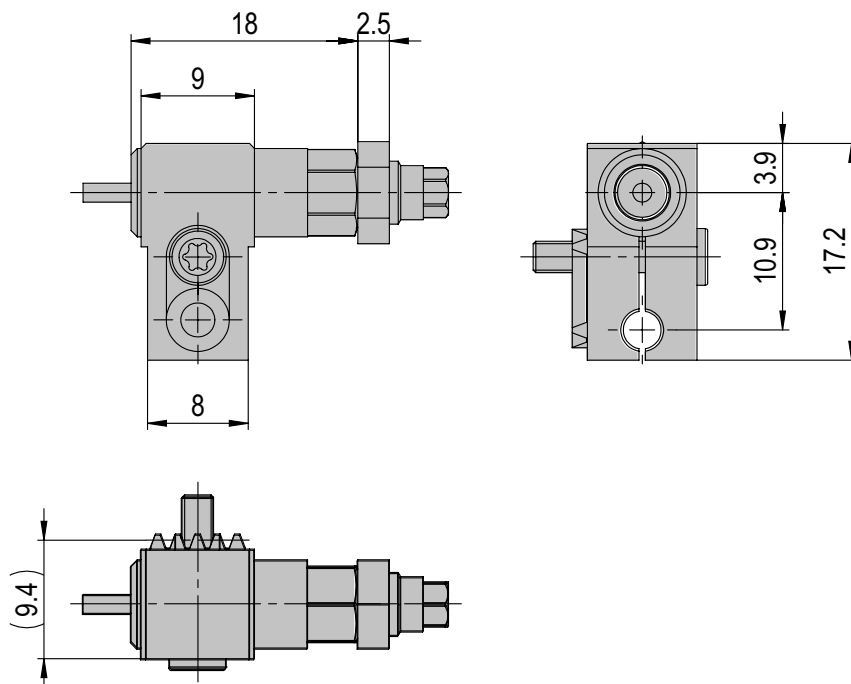

Accessories CS

SDH-fastening CS 12

Order number

50568150

Net weight

0.01 kg

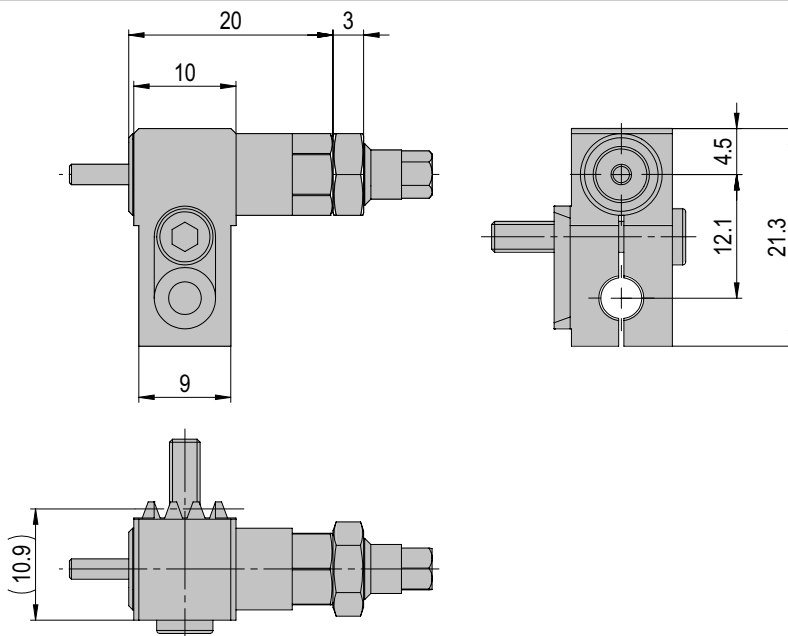

Installation set inductive switch CS

CS 16/CS 20 CS 25

Order number

50242140

50242141

Net weight

0.001 kg

0.001 kg



Note: Application purpose: See operating manual