

# Phase angle controller

## IRG 1-S



- Optimal control of vibration conveyors
- Modular combination concept and external control by higher-level system

Type	IRG1-S
A	175 mm
B	80 mm
C	60 mm
D	24 mm
E	25 mm

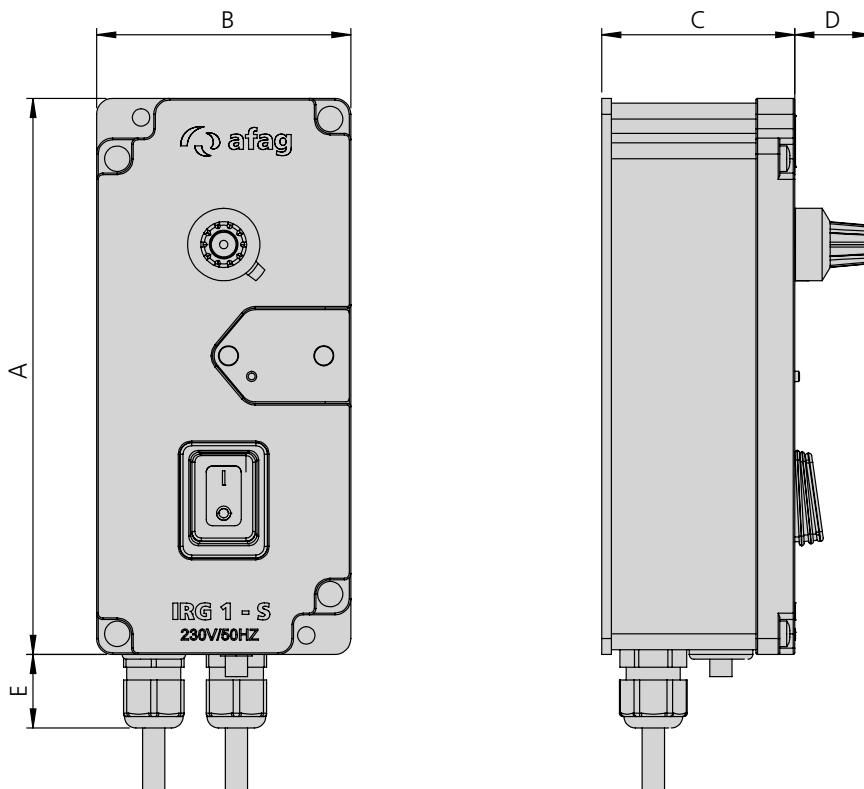



IRG1-S			
Operating temperature	0 - 45 °C		
Type	IRG1-S	IRG1-S	
<b>Order number</b>	<b>50360105</b>	<b>50360106</b>	
External target value preset	0 - 20 mA (DC), 0 - 10 VDC	0 - 20 mA (DC), 0 - 10 VDC	
Nominal output current	6 A AC	6 A AC	
Input voltage	230 VAC	115 VAC	
Output voltage	40 - 228 VAC	20 - 100 VAC	
Supply voltage compensation	•	•	
Net weight	1.3 kg	1.2 kg	
Alternation operation	•	•	
Smooth start	0 - 4 s	0 - 4 s	
Continuous operation	•	•	
Operating mode display	LED	LED	
Input of optical coupler invertable	•	•	
Refillable vibratory hopper NVB	•	•	
Vibratory hopper NVD	•	•	
Industrial belt hopper IBB	---	---	
Vibrator	•	•	
Plug connector/pins	M8/4-pol.	M8/4-pol.	
Protection type	IP54	IP54	

Note: • = existent/suitable for --- = not suitable for