

**Mechanische** Komponenten  
*Mechanical* Components

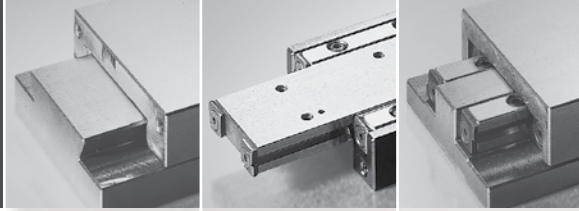



## **FERTIGUNG**

Föhrenbach-Präzisions-Schlittenführungen sind in zwei maßlich identischen Baureihen in Schwalbenschwanz-Ausführung oder rollengelagert lieferbar. Sie werden in genormten Breiten von 30 bis 400 mm und Längen von 35 bis 1800 mm hergestellt. Durch den baukastenähnlichen Aufbau kann praktisch für jede Problemstellung eine technisch und preislich optimale Ausführung geliefert werden.

Die Verwendung bester Materialien, langjährige Erfahrung und Serienfertigung garantieren gleichbleibende Qualität und Präzision.

## **KONSTRUKTIONSMERKMALE**

Schwalbenschwanz-Schlitten werden aus den Materialien GG 25 und Alu gefertigt. Die Spieleinstellung erfolgt über eine Zustelleiste. Sämtliche Ausführungen sind mit Schmier-nippeln und Schmiernuten versehen. Alle Außenflächen sind geschliffen, die Führungen feingefräst. Rollengelagerte Schlitten in Einzelachsen- oder Mehrachsenausführungen werden ebenso in den Materialien GG 25 und Alu geliefert. Alu-Ausführungen sind schwarz anodisiert. Schlitten für höhere Belastungen können in verstärkter Ausführung geliefert werden. Die rollengelagerten Schlitten sind in vorgespannten, gehärteten und geschliffenen Prismenführungen gelagert. Sie garantieren auch unter hoher Belastung eine leichtgängige, spielfreie und äußerst präzise Längsbewegung. Gegenüber Gleitführungen (Schwalbenschwanz-ausführung) gestatten sie ein genaues, spiel-freies und leichtes Verschieben von Teilen.

## **EINSATZGEBIETE**

Allgemeiner Maschinenbau  
Sondermaschinenbau  
Vorrichtungs- und Meßgerätebau  
Optische und feinmechanische Industrie in  
Versuchs- und Forschungswerkstätten

Technische Änderungen vorbehalten.

## **MANUFACTURE**

*The Föhrenbach precision sliding guides are on sale in two series of identical sizes, either as dovetail guide type or as sliding guides that run on roller bearings.*

*They are manufactured in standard widths from 30 to 400 mm and in lengths from 35 to 1800 mm. The unitized construction realized with these devices enables to supply technically optimized solutions at best prices that meet with the requirement of almost all problematic cases.*

*Use of best materials, an experience of long standing as well as series production guarantee for permanent quality and precision.*

## **CONSTRUCTION FEATURES**

*The Föhrenbach dovetail guides are made of grey cast iron (GG 25) and of aluminium. The play is adjusted by means of an adjusting bar.*

*All types are equipped with greasing nipples and greasing grooves. All outside surfaces are ground and the guides milled fine. Also on sale are one axe or multi-axe slide types that run on roller bearings. These are made of grey cast iron (GG 25) or of aluminium. Aluminium models are anodized black. Slides for higher loads can be delivered as reinforced execution. The Föhrenbach slide types that run on roller bearings run in prestressed, hardened and ground Vee-guides. Even under high loads they assure smooth running operation, free from play and guarantee an extremely precise lengthwise motion. As compared to guide rails (dovetail type) they enable exact and easy displacement of parts, free from play.*

## **APPLICATION FIELDS**

*General machine construction  
Construction of special purpose machines  
Construction of jigs and fixtures and of measuring devices  
Optics and precision mechanics industry in test and research workshops*

*Technical modifications reserved.*



4	<b>1.0</b>	Schwalbenschwanz-Schlitten	<i>Dovetail slides</i>
12	<b>2.0</b>	Rollen-Schlitten	<i>Roller slides</i>
20	<b>3.0</b>	Rollen-Schlitten in abgedichteter Ausführung	<i>Roller slides, sealed models</i>
22	<b>4.0</b>	Miniatur-Rollen-Schlitten	<i>Miniature roller slides</i>
24	<b>5.0</b>	Kreuzschlitten	<i>Cross slides</i>
25	<b>6.0</b>	Toleranzen	<i>Tolerances</i>
26	<b>7.0</b>	Ersatzteile	<i>Spare parts</i>
	<b>7.1</b>	Kreuzrollen-Führungsschienen	<i>Cross roller guide rails</i>
	<b>7.2</b>	Rollenkäfige	<i>Roller cages</i>
	<b>7.3</b>	Gewindespindeln	<i>Threaded spindles</i>
31	<b>8.0</b>	Sonderausführungen	<i>Special types</i>
	<b>8.1</b>	Arretierung	<i>Locking</i>
	<b>8.2</b>	Abdichtung durch Abstreifer	<i>Sealing through scrapers</i>
	<b>8.3</b>	Faltenbalg-Abdeckung	<i>Bellows cover</i>
	<b>8.4</b>	T-Nuten	<i>T-slots</i>
	<b>8.5</b>	Positionsanzeige PA	<i>Position readout</i>
35	<b>9.0</b>	Zubehör	<i>Accessories</i>
	<b>9.1</b>	Montage-Winkel	<i>Mounting flanges</i>
	<b>9.2</b>	Drehteller	<i>Turntables</i>
36	<b>10.0</b>	Bohrbilder	<i>Drilling plans</i>
38	<b>11.0</b>	Bestellschlüssel	<i>Order code</i>
39	<b>12.0</b>	Verkaufsbedingungen	<i>General Terms and Conditions of Sale</i>



Diese Druckschrift wurde mit großer Sorgfalt erstellt und alle Angaben auf ihre Richtigkeit geprüft. Für etwaige fehlerhafte oder unvollständige Angaben kann jedoch keine Haftung übernommen werden. Aus Gründen der ständigen Weiterentwicklung unserer Erzeugnisse müssen Änderungen vorbehalten bleiben.

*This printed matter has been established with great care and all information, specifications and data contained herein have been checked for correctness. However, we cannot assume any liabilities whatsoever for any incorrect or incomplete specifications or data contained in this catalogue. For reason of permanent advancement of our products all information, specifications and data contained herein are subject to change.*



Schwalbenschwanz-Schlitten sind robuste aber dennoch präzise Positioniermodule für die unterschiedlichsten Anwendungen. Standardschlitten sind aus GG 25 gefertigt, andere Werkstoffe sind auf Anfrage erhältlich. Die Tischauflagefläche ist geschliffen. Die Führungen sind feingefräst. Alle Baugrößen sind mit Schmiernuten ausgestattet.

*The dovetail guides are robust, but nevertheless highly precise positioning modules for the most different applications and tasks. The standard dovetail guides are made of grey cast iron (GG 25), but makes of other materials are possible, too. All table supporting surfaces are ground. The guides are milled fine and all types are equipped with greasing grooves.*

	<p><b>SO</b></p> <p>offene Ausführung</p>	<p><i>open type</i></p>
	<p><b>SE</b></p> <p>Die Baureihe SE mit Endplatten eignet sich zum Anbau von Anschlägen, Mikrometern, Zylindern etc.</p>	<p><i>The SE line is equipped with end plates and suits for attachment of stops, micrometers, cylinders etc.</i></p>
	<p><b>SS</b></p> <p>Die Baureihe SS ist mit einer Gewindespindel ausgestattet. Nähere Informationen zu den verwendeten Spindeln finden Sie auf Seite 30.</p>	<p><i>The SS line is equipped with a threaded spindle. As for further detailed information on the spindle types used please refer to page 30</i></p>
	<p><b>SM</b></p> <p>Die Baureihe SM ist mit einer Mikrometer- randel mit Skalenteilung 0,02 mm ausgestattet, die Baugrößen 075 bis 200 können optional auch mit Skalenteilung 0,01 mm geliefert werden.</p>	<p><i>The SM line is equipped with a knurled micrometer knob with a 0.02 mm scale gradation. Sizes 075 up to 200 can, on option, also be furnished with a 0.01 scale gradation.</i></p>
	<p><b>SK</b></p> <p>Die Baureihe SK ist mit einer Kreuzkurbel, ab Baugröße 300 mit einem Handrad ausgestattet.</p>	<p><i>The SK line is equipped with a cross type crank handle and, from size 300 on, with a hand wheel.</i></p>

**SO**  
normal montiert  
*mounted normal*

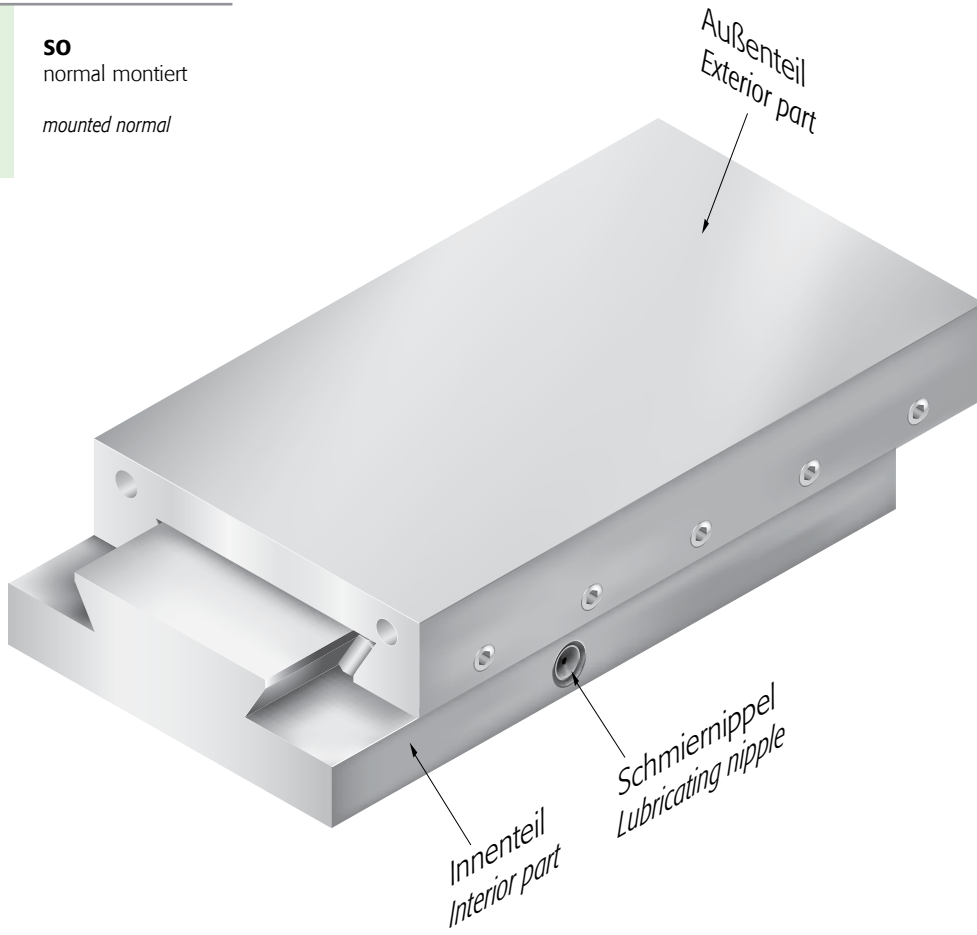

**SO**  
umgekehrt montiert  
*mounted reversed*

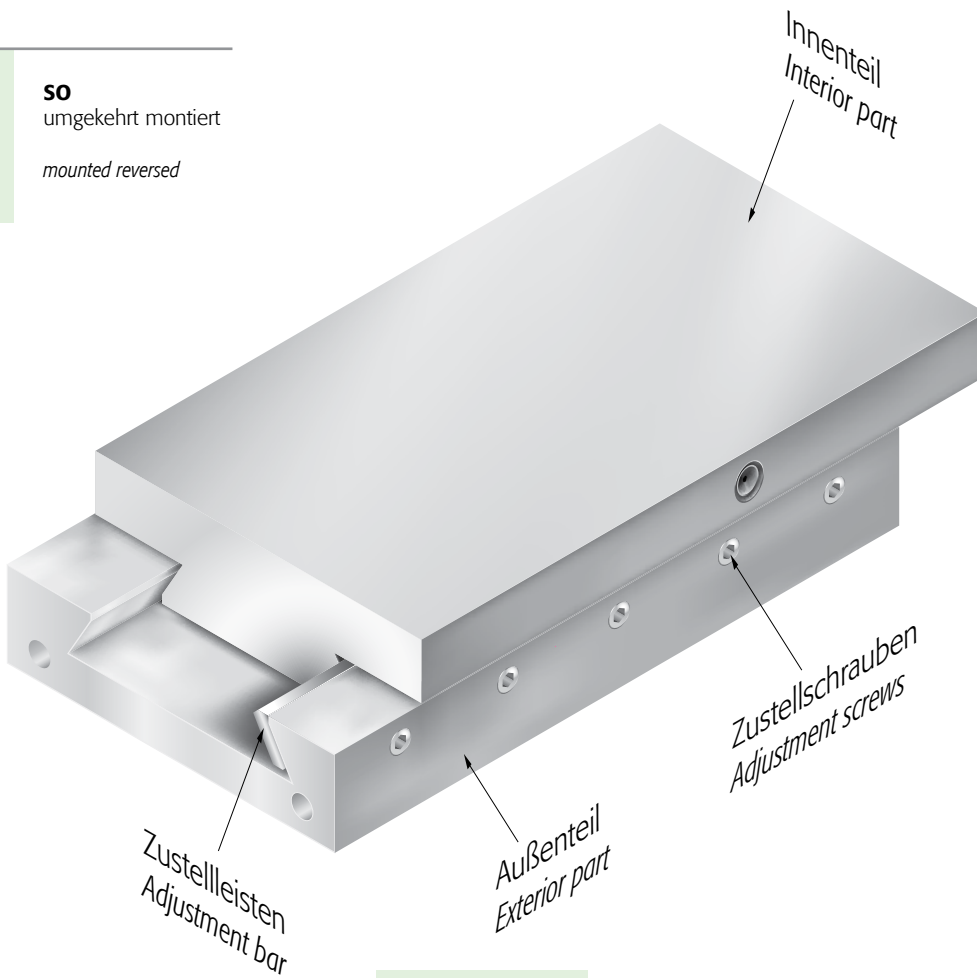

**Schwalbenschwanz-Schlitten, Grundmaße für alle Baureihen**  
*Dovetail slides, standard sizes for all lines*

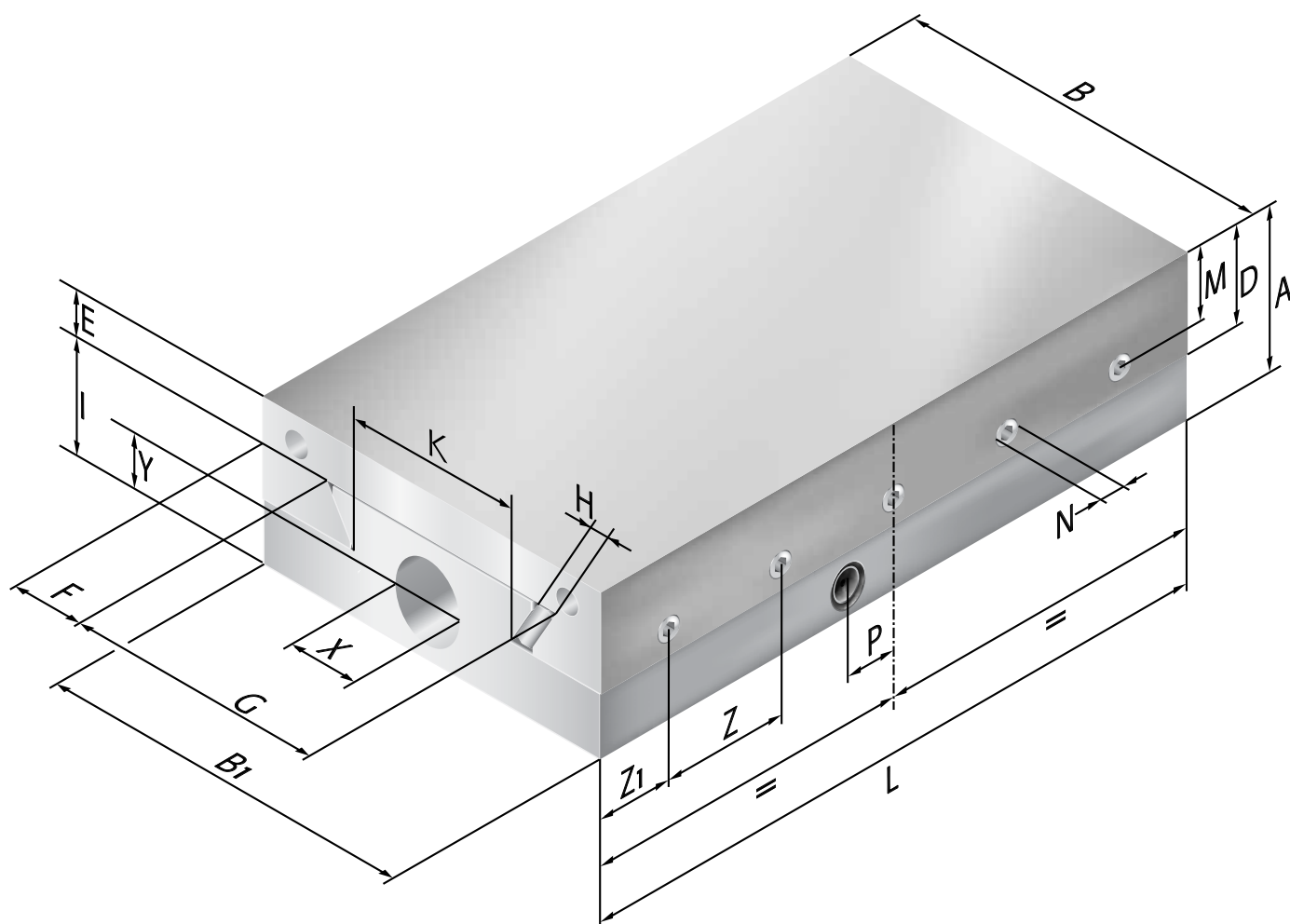

\* nicht bei SO  
 \* not with SO

Größe Size	B	A	B1	D	E	F	G	H	I	K	M	N	X*	Y*
<b>050</b>	50	25	49,5	15,0	7	10,0	33,5	3,0	17,6	21,0	11,0	M 5	9	12,3
<b>075</b>	75	32	74,5	19,5	9	14,0	51,5	3,7	22,5	34,6	14,5	M 5	14	15,0
<b>100</b>	100	40	99,5	24,0	12	18,0	69,5	4,6	27,5	50,0	18,5	M 6	14	19,0
<b>150</b>	150	50	149,0	29,5	14	27,0	103,0	5,7	35,5	79,0	22,5	M 8	20	24,0
<b>200</b>	200	60	199,0	37,0	18	35,0	138,5	7,5	41,5	107,5	28,0	M 8	20	25,0
<b>300</b>	300	75	299,0	50,0	25	50,0	210,0	9,0	49,0	170,0	38,0	M 10	26	34,5
<b>400</b>	400	100	399,0	70,0	38	71,5	270,5	11,8	61,0	220,0	54,0	M 10	26	36,0

**1.1 SO**  
offene Ausführung

open type



**Schwalbenschwanz-Schlitten, Baureihe SO**  
Dovetail slides, SO line

Größe Size	Länge Length	Hub Stroke	Höhe Height	Höhe m. T-Nuten Height incl. T-slots	Schmierbohrung Greasing hole	Mögl. Stand.-Bohrbild Possible standard drilling plan			Gewicht Weight	Gewicht mit T-Nuten Weight incl. T-slots	
B	L	C	A	A	P	Z	Z1	AR**	Ba* + Bi*	kg	kg
050	080	030	25	35	10	25 x 2	15,0	1	2 x a	0,71	0,95
050	105	040	25	35	10	25 x 3	15,0	1	3 x a	0,93	1,24
050	130	050	25	35	10	25 x 4	15,0	1	4 x a	1,15	1,53
050	155	060	25	35	10	25 x 5	15,0	1	5 x a	1,37	1,83
050	180	070	25	35	10	25 x 6	15,0	1	6 x a	1,60	2,13
050	205	080	25	35	10	25 x 7	15,0	1	7 x a	1,83	2,43
075	105	040	32	44	10	25 x 3	15,0	1	1 x a	1,77	2,38
075	130	050	32	44	10	25 x 4	15,0	1	1 x a	2,19	3,04
075	155	060	32	44	10	25 x 5	15,0	1	2 x a	2,62	3,52
075	180	070	32	44	10	25 x 6	15,0	1	2 x a	3,03	4,08
075	205	080	32	44	10	25 x 7	15,0	1	3 x a	3,45	4,64
075	255	100	32	44	10	25 x 9	15,0	1	3 x a	4,30	5,78
075	305	120	32	44	10	25 x 11	15,0	1	4 x a	5,13	6,91
100	110	040	40	50	10	25 x 3	17,5	1	1 x a	3,12	3,77
100	135	050	40	50	10	25 x 4	17,5	1	1 x a	3,82	4,62
100	160	060	40	50	10	25 x 5	17,5	1	1 x a	4,53	5,48
100	210	080	40	50	10	25 x 7	17,5	1	2 x a	5,96	7,19
100	260	100	40	50	10	25 x 9	17,5	1	2 x a	7,37	8,90
100	310	120	40	50	10	25 x 11	17,5	1	3 x a	8,79	10,61
100	360	140	40	50	10	25 x 13	17,5	1	3 x a	10,20	12,32
100	410	160	40	50	10	25 x 15	17,5	1	4 x a	11,62	14,03
100	460	180	40	50	10	25 x 17	17,5	1	5 x a	13,03	15,74
100	510	200	40	50	10	25 x 19	17,5	1	5 x a	14,45	17,45
150	160	060	50	66	15	50 x 2	30,0	1	1 x a	8,53	10,91
150	210	080	50	66	15	50 x 3	30,0	1	1 x a	11,19	14,31
150	260	100	50	66	15	50 x 4	30,0	1	1 x a	13,85	17,71
150	310	120	50	66	15	50 x 5	30,0	1	2 x a	16,52	21,12
150	360	140	50	66	15	50 x 6	30,0	1	2 x a	19,18	24,53
150	410	160	50	66	15	50 x 7	30,0	1	3 x a	21,84	27,93
150	460	180	50	66	15	50 x 8	30,0	1	3 x a	24,50	31,33
150	510	200	50	66	15	50 x 9	30,0	1	3 x a	27,17	34,75
150	610	240	50	66	15	50 x 11	30,0	1	4 x a	32,49	41,55
150	710	280	50	66	15	50 x 13	30,0	1	5 x a	37,82	48,37
150	810	320	50	66	15	50 x 15	30,0	1	6 x a	43,16	55,18
200	210	080	60	75	15	50 x 3	30,0	1	1 x a	17,95	21,98
200	260	100	60	75	15	50 x 4	30,0	1	1 x a	22,22	27,21
200	310	120	60	75	15	50 x 5	30,0	1	1 x a	26,50	32,45
200	410	160	60	75	15	50 x 7	30,0	1	2 x a	35,04	42,90
200	510	200	60	75	15	50 x 9	30,0	1	2 x a	43,59	43,37
200	610	240	60	75	15	50 x 11	30,0	1	3 x a	52,14	63,83
200	710	280	60	75	15	50 x 13	30,0	1	4 x a	60,69	74,29
200	810	320	60	75	15	50 x 15	30,0	1	4 x a	69,24	84,76
200	1010	400	60	75	15	50 x 19	30,0	1	5 x a	86,33	105,69
300	310	120	75	95	15	50 x 5	30,0	1	1 x a	49,78	61,53
300	410	160	75	95	15	50 x 7	30,0	1	1 x a	65,83	81,37
300	460	180	75	95	15	50 x 8	30,0	1	1 x a	73,86	91,29
300	510	200	75	95	15	50 x 9	30,0	1	1 x a	81,89	101,21
300	610	240	75	95	15	50 x 11	30,0	1	2 x a	97,95	121,06
300	710	280	75	95	15	50 x 13	30,0	1	2 x a	114,01	140,91
300	810	320	75	95	15	50 x 15	30,0	1	3 x a	130,06	160,75
300	1010	400	75	95	15	50 x 19	30,0	1	3 x a	162,17	200,44
400	410	160	100	125	15	50 x 7	30,0	1	1 x a	116,33	142,58
400	510	200	100	125	15	50 x 9	30,0	1	1 x a	145,08	177,35
400	610	240	100	125	15	50 x 11	30,0	1	1 x a	173,52	212,14
400	710	280	100	125	15	50 x 13	30,0	1	2 x a	201,97	246,91
400	810	320	100	125	15	50 x 15	30,0	1	2 x a	230,42	281,68
400	1010	400	100	125	15	50 x 19	30,0	1	2 x a	287,31	351,24
400	1210	480	100	125	15	50 x 23	30,0	1	3 x a	344,21	420,79

**1.2 SE**  
mit Endplatten  
with end plates

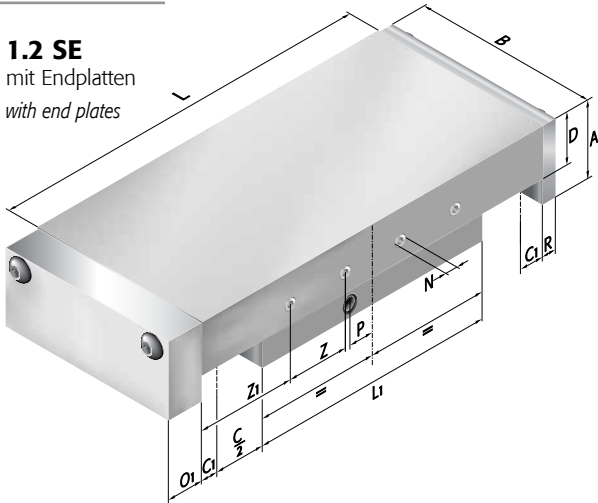

**1.3 SS**  
mit Spindel  
with spindle

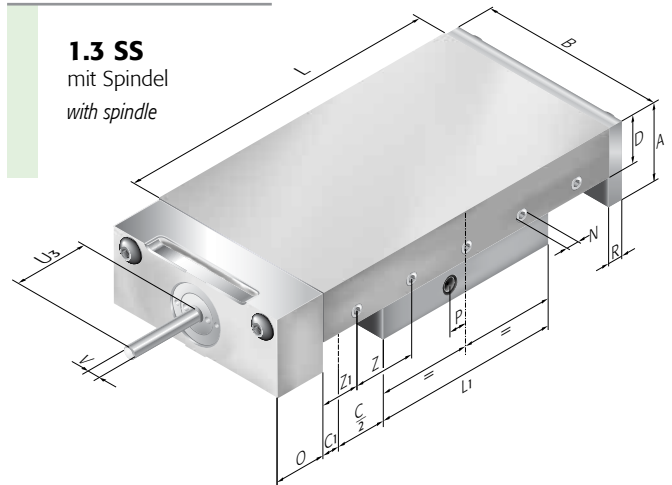

Maßtabelle Baugrößen 50 - 150 | Size table, sizes 50 - 150

Größe Size	Länge Length	Hub Stroke		Höhe Height	Höhe m. T-Nuten Height incl. T-slots A-TN	Schmierbohrung Greasing hole							
		C	C1			L1	A	N	D	P	O	O1	R
<b>050</b>	<b>080</b>	<b>025</b>	<b>2,5</b>	<b>50</b>	<b>25</b>	<b>35</b>	<b>M5</b>	<b>15,0</b>	<b>0</b>	<b>19</b>	<b>14</b>	<b>6</b>	<b>47</b>
050	105	025	2,5	75	25	35	M5	15,0	10	19	14	6	47
050	105	050	2,5	50	25	35	M5	15,0	0	19	14	6	47
050	130	025	2,5	100	25	35	M5	15,0	10	19	14	6	47
050	130	050	2,5	75	25	35	M5	15,0	10	19	14	6	47
050	155	050	2,5	100	25	35	M5	15,0	10	19	14	6	47
050	155	075	2,5	75	25	35	M5	15,0	10	19	14	6	47
050	180	075	2,5	100	25	35	M5	15,0	10	19	14	6	47
050	205	050	2,5	150	25	35	M5	15,0	10	19	14	6	47
050	205	075	2,5	125	25	35	M5	15,0	10	19	14	6	47
050	205	100	2,5	100	25	35	M5	15,0	10	19	14	6	47
<b>075</b>	<b>105</b>	<b>025</b>	<b>2,5</b>	<b>75</b>	<b>32</b>	<b>44</b>	<b>M5</b>	<b>19,5</b>	<b>0</b>	<b>21</b>	<b>15</b>	<b>6</b>	<b>47</b>
075	130	050	2,5	75	32	44	M5	19,5	0	21	15	6	47
075	155	050	2,5	100	32	44	M5	19,5	10	21	15	6	47
075	155	075	2,5	75	32	44	M5	19,5	0	21	15	6	47
075	180	075	2,5	100	32	44	M5	19,5	10	21	15	6	47
075	205	050	2,5	150	32	44	M5	19,5	10	21	15	6	47
075	205	100	2,5	100	32	44	M5	19,5	10	21	15	6	47
075	255	050	2,5	200	32	44	M5	19,5	10	21	15	6	47
075	255	100	2,5	150	32	44	M5	19,5	10	21	15	6	47
075	305	100	2,5	200	32	44	M5	19,5	10	21	15	6	47
075	305	150	2,5	150	32	44	M5	19,5	10	21	15	6	47
<b>100</b>	<b>110</b>	<b>025</b>	<b>5,0</b>	<b>75</b>	<b>40</b>	<b>50</b>	<b>M6</b>	<b>24,0</b>	<b>0</b>	<b>21</b>	<b>15</b>	<b>6</b>	<b>47</b>
100	135	025	5,0	100	40	50	M6	24,0	10	21	15	6	47
100	160	050	5,0	100	40	50	M6	24,0	10	21	15	6	47
100	210	050	5,0	150	40	50	M6	24,0	10	21	15	6	47
100	210	100	5,0	100	40	50	M6	24,0	10	21	15	6	47
100	260	050	5,0	200	40	50	M6	24,0	10	21	15	6	47
100	260	100	5,0	150	40	50	M6	24,0	10	21	15	6	47
100	310	100	5,0	200	40	50	M6	24,0	10	21	15	6	47
100	310	150	5,0	150	40	50	M6	24,0	10	21	15	6	47
100	360	150	5,0	200	40	50	M6	24,0	10	21	15	6	47
100	410	100	5,0	300	40	50	M6	24,0	10	21	15	6	47
100	410	150	5,0	250	40	50	M6	24,0	10	21	15	6	47
100	410	200	5,0	200	40	50	M6	24,0	10	21	15	6	47
100	410	250	5,0	150	40	50	M6	24,0	10	21	15	6	47
100	460	250	5,0	200	40	50	M6	24,0	10	21	15	6	47
100	510	200	5,0	300	40	50	M6	24,0	10	21	15	6	47
100	510	300	5,0	200	40	50	M6	24,0	10	21	15	6	47
<b>150</b>	<b>210</b>	<b>050</b>	<b>5,0</b>	<b>150</b>	<b>50</b>	<b>66</b>	<b>M8</b>	<b>29,5</b>	<b>15</b>	<b>28</b>	<b>16</b>	<b>8</b>	<b>103</b>
150	260	050	5,0	200	50	66	M8	29,5	15	28	16	8	103
150	260	100	5,0	150	50	66	M8	29,5	15	28	16	8	103
150	310	100	5,0	200	50	66	M8	29,5	15	28	16	8	103
150	310	150	5,0	150	50	66	M8	29,5	15	28	16	8	103
150	360	150	5,0	200	50	66	M8	29,5	15	28	16	8	103
150	410	100	5,0	300	50	66	M8	29,5	15	28	16	8	103
150	410	200	5,0	200	50	66	M8	29,5	15	28	16	8	103
150	460	150	5,0	300	50	66	M8	29,5	15	28	16	8	103
150	460	250	5,0	200	50	66	M8	29,5	15	28	16	8	103



**1.4 SM**  
mit Mikrometerrandel  
with knurled micrometer  
knob

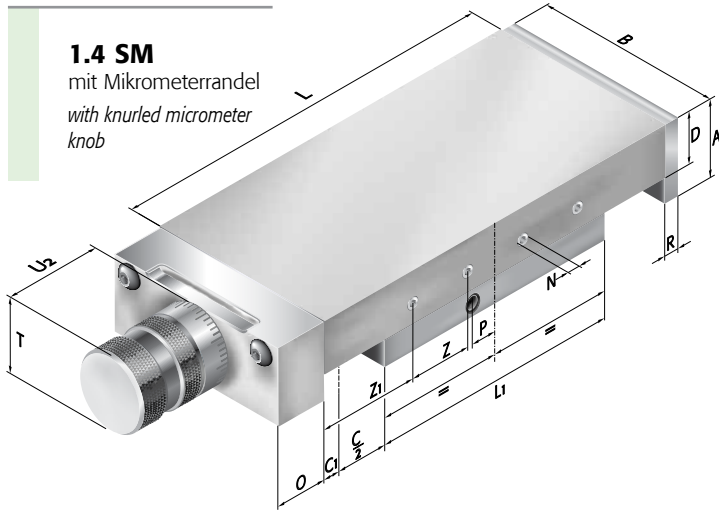

**1.5 SK**  
mit Kreuzkurbel  
with cross type  
handle

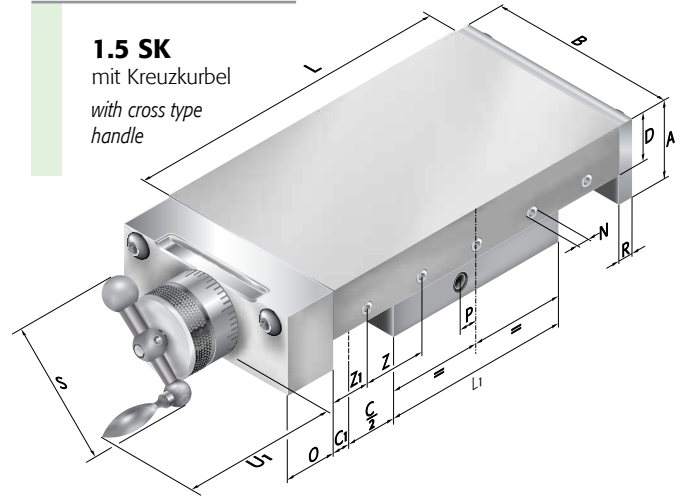

T	U1	U2	U3	V	Spindel Spindle		AR**	Mögl. Stand.-Bohrbild Possible standard drilling plan		Gewicht Weight kg (GG 25)	Gewicht m. T-Nuten Weight incl. T-slots kg (GG 25)	Gewicht Weight kg (Al)	Gewicht m. T-Nuten Weight incl. T-slots kg (Al)	
					Z	Z1		Ba*	Bi*					
<b>23,5</b>	<b>51</b>	<b>31</b>	<b>27</b>	<b>5j5</b>	<b>M6 x 1</b>	<b>25 x 2</b>	<b>15,0</b>	<b>1</b>	<b>2 x a</b>	<b>1 x a</b>	<b>0,72</b>	<b>0,95</b>	<b>0,40</b>	<b>0,49</b>
23,5	51	31	27	5j5	M6 x 1	25 x 3	15,0	1	3 x a	2 x a	0,94	1,25	0,49	0,62
23,5	51	31	27	5j5	M6 x 1	25 x 3	15,0	2	3 x a	1 x a	0,83	1,13	0,45	0,57
23,5	51	31	27	5j5	M6 x 1	25 x 4	15,0	1	4 x a	3 x a	1,16	1,54	0,59	0,74
23,5	51	31	27	5j5	M6 x 1	25 x 4	15,0	1	4 x a	2 x a	1,04	1,43	0,55	0,70
23,5	51	31	27	5j5	M6 x 1	25 x 5	15,0	1	5 x a	3 x a	1,26	1,72	0,64	0,82
23,5	51	31	27	5j5	M6 x 1	25 x 5	15,0	2	5 x a	2 x a	1,15	1,61	0,60	0,78
23,5	51	31	27	5j5	M6 x 1	25 x 6	15,0	1	6 x a	3 x a	1,38	1,91	0,70	0,91
23,5	51	31	27	5j5	M6 x 1	25 x 7	15,0	1	7 x a	4 x a	1,71	2,32	0,84	1,08
23,5	51	31	27	5j5	M6 x 1	25 x 7	15,0	1	7 x a	4 x a	1,60	2,21	0,80	1,04
23,5	51	31	27	5j5	M6 x 1	25 x 7	15,0	2	7 x a	3 x a	1,49	2,09	0,76	1,00
<b>30,0</b>	<b>54</b>	<b>38</b>	<b>31</b>	<b>5h7</b>	<b>M10 x 1</b>	<b>25 x 3</b>	<b>15,0</b>	<b>1</b>	<b>1 x a</b>	<b>1 x a</b>	<b>1,91</b>	<b>2,52</b>	<b>1,08</b>	<b>1,32</b>
30,0	54	38	31	5h7	M10 x 1	25 x 4	15,0	1	1 x a	1 x a	2,13	2,88	1,18	1,48
30,0	54	38	31	5h7	M10 x 1	25 x 5	15,0	1	1 x a	1 x a	2,55	3,45	1,38	1,73
30,0	54	38	31	5h7	M10 x 1	25 x 5	15,0	2	1 x a	1 x a	2,34	3,24	1,29	1,65
30,0	54	38	31	5h7	M10 x 1	25 x 6	15,0	1	2 x a	1 x a	2,75	3,80	1,47	1,89
30,0	54	38	31	5h7	M10 x 1	25 x 7	15,0	1	2 x a	2 x a	3,38	4,58	1,75	2,22
30,0	54	38	31	5h7	M10 x 1	25 x 7	15,0	2	2 x a	1 x a	2,97	4,16	1,58	2,06
30,0	54	38	31	5h7	M10 x 1	25 x 9	15,0	1	3 x a	2 x a	4,23	5,72	2,13	2,72
30,0	54	38	31	5h7	M10 x 1	25 x 9	15,0	1	3 x a	2 x a	3,81	5,30	1,96	2,55
30,0	54	38	31	5h7	M10 x 1	25 x 11	15,0	1	4 x a	2 x a	4,65	6,42	2,34	3,04
30,0	54	38	31	5h7	M10 x 1	25 x 11	15,0	2	4 x a	2 x a	4,23	6,01	2,17	2,88
<b>30,0</b>	<b>54</b>	<b>38</b>	<b>31</b>	<b>5h7</b>	<b>M10 x 1</b>	<b>25 x 3</b>	<b>17,5</b>	<b>1</b>	<b>1 x a</b>	<b>60 x 86</b>	<b>3,34</b>	<b>3,99</b>	<b>1,81</b>	<b>2,07</b>
30,0	54	38	31	5h7	M10 x 1	25 x 4	17,5	1	1 x a	1 x a	4,04	4,84	2,11	2,43
30,0	54	38	31	5h7	M10 x 1	25 x 5	17,5	1	1 x a	1 x a	4,38	5,32	2,27	2,64
30,0	54	38	31	5h7	M10 x 1	25 x 7	17,5	1	1 x a	1 x a	5,80	7,04	2,88	3,37
30,0	54	38	31	5h7	M10 x 1	25 x 7	17,5	2	1 x a	1 x a	5,05	6,29	2,59	3,08
30,0	54	38	31	5h7	M10 x 1	25 x 9	17,5	1	2 x a	2 x a	7,21	8,74	3,49	4,10
30,0	54	38	31	5h7	M10 x 1	25 x 9	17,5	1	2 x a	1 x a	6,46	7,79	3,19	3,80
30,0	54	38	31	5h7	M10 x 1	25 x 11	17,5	1	3 x a	2 x a	7,88	9,71	3,81	4,53
30,0	54	38	31	5h7	M10 x 1	25 x 11	17,5	2	3 x a	1 x a	7,14	8,96	3,51	4,24
30,0	54	38	31	5h7	M10 x 1	25 x 13	17,5	1	3 x a	2 x a	8,55	10,67	4,11	4,96
30,0	54	38	31	5h7	M10 x 1	25 x 15	17,5	1	4 x a	3 x a	10,72	13,13	5,03	5,99
30,0	54	38	31	5h7	M10 x 1	25 x 15	17,5	1	4 x a	2 x a	9,97	12,38	4,73	5,69
30,0	54	38	31	5h7	M10 x 1	25 x 15	17,5	2	4 x a	2 x a	9,22	11,64	4,43	5,39
30,0	54	38	31	5h7	M10 x 1	25 x 15	17,5	2	4 x a	1 x a	8,48	10,89	4,14	5,10
30,0	54	38	31	5h7	M10 x 1	25 x 17	17,5	2	4 x a	2 x a	9,89	12,60	4,74	5,82
30,0	54	38	31	5h7	M10 x 1	25 x 19	17,5	1	5 x a	3 x a	12,05	15,06	5,65	6,85
30,0	54	38	31	5h7	M10 x 1	25 x 19	17,5	2	5 x a	2 x a	10,56	13,56	5,06	6,25
<b>47,0</b>	<b>92</b>	<b>53</b>	<b>40</b>	<b>10h7</b>	<b>Tr16 x 2</b>	<b>50 x 3</b>	<b>30,0</b>	<b>1</b>	<b>1 x a</b>	<b>1 x a</b>	<b>11,50</b>	<b>14,62</b>	<b>6,05</b>	<b>7,29</b>
47,0	92	53	40	10h7	Tr16 x 2	50 x 4	30,0	1	1 x a	1 x a	14,16	18,02	7,20	8,73
47,0	92	53	40	10h7	Tr16 x 2	50 x 4	30,0	1	1 x a	1 x a	12,71	16,57	6,62	8,16
47,0	92	53	40	10h7	Tr16 x 2	50 x 5	30,0	1	2 x a	1 x a	15,38	19,98	7,78	9,61
47,0	92	53	40	10h7	Tr16 x 2	50 x 5	30,0	2	2 x a	1 x a	13,93	18,53	7,21	9,03
47,0	92	53	40	10h7	Tr16 x 2	50 x 6	30,0	1	2 x a	1 x a	16,59	21,82	8,35	10,48
47,0	92	53	40	10h7	Tr16 x 2	50 x 7	30,0	1	3 x a	2 x a	20,70	26,79	10,08	12,49
47,0	92	53	40	10h7	Tr16 x 2	50 x 7	30,0	2	3 x a	1 x a	17,80	23,89	8,92	11,34
47,0	92	53	40	10h7	Tr16 x 2	50 x 8	30,0	1	3 x a	2 x a	21,91	28,74	10,65	13,36
47,0	92	53	40	10h7	Tr16 x 2	50 x 8	30,0	2	3 x a	1 x a	19,01	25,84	9,49	12,21

**1.2 SE**  
mit Endplatten  
with end plates

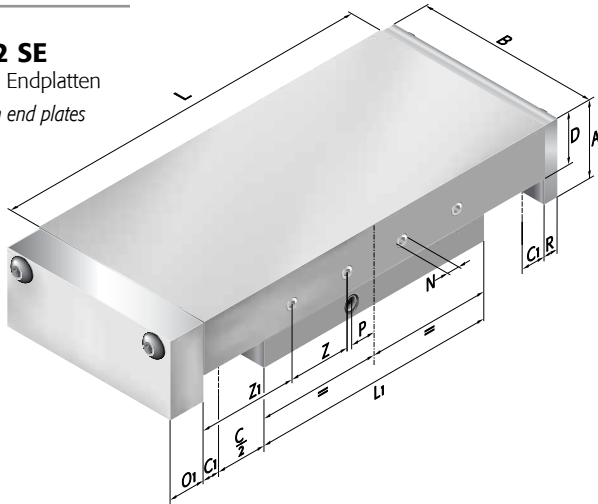

**1.3 SS**  
mit Spindel  
with spindle

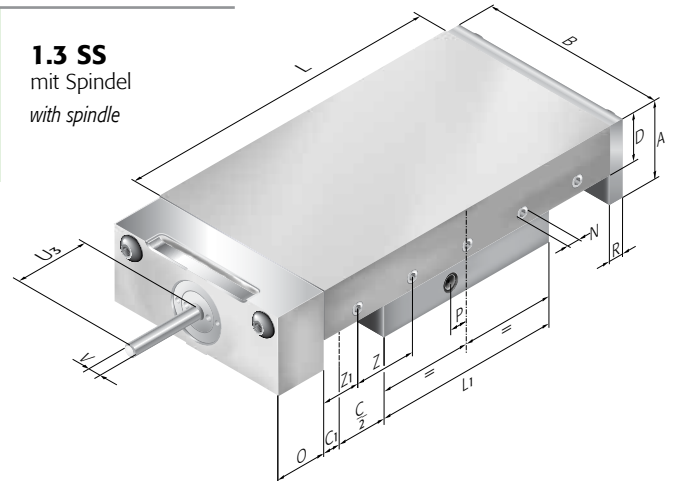

Maßtabelle Baugrößen 200 - 400 | Size table, sizes 200 - 400

Größe Size	Länge Length	Hub Stroke	Höhe Height			Höhe m. T-Nuten Height incl. T-slots			Schmierbohrung Greasing hole					
			B	L	C	A	A	N	D	P	O	O1	R	S
150	510	100	5,0	400	50	66	M8	29,5	15	28	16	8	103	
150	510	200	5,0	300	50	66	M8	29,5	15	28	16	8	103	
150	510	300	5,0	200	50	66	M8	29,5	15	28	16	8	103	
150	610	200	5,0	400	50	66	M8	29,5	15	28	16	8	103	
150	610	300	5,0	300	50	66	M8	29,5	15	28	16	8	103	
150	710	300	5,0	400	50	66	M8	29,5	15	28	16	8	103	
150	710	400	5,0	300	50	66	M8	29,5	15	28	16	8	103	
150	810	400	5,0	400	50	66	M8	29,5	15	28	16	8	103	
150	810	500	5,0	300	50	66	M8	29,5	15	28	16	8	103	
200	310	100	5,0	200	60	75	M8	37,0	15	28	16	8	103	
200	410	100	5,0	300	60	75	M8	37,0	15	28	16	8	103	
200	410	200	5,0	200	60	75	M8	37,0	15	28	16	8	103	
200	510	200	5,0	300	60	75	M8	37,0	15	28	16	8	103	
200	510	300	5,0	200	60	75	M8	37,0	15	28	16	8	103	
200	610	200	5,0	400	60	75	M8	37,0	15	28	16	8	103	
200	610	300	5,0	300	60	75	M8	37,0	15	28	16	8	103	
200	610	400	5,0	200	60	75	M8	37,0	15	28	16	8	103	
200	710	300	5,0	400	60	75	M8	37,0	15	28	16	8	103	
200	710	400	5,0	300	60	75	M8	37,0	15	28	16	8	103	
200	710	500	5,0	200	60	75	M8	37,0	15	28	16	8	103	
200	810	400	5,0	400	60	75	M8	37,0	15	28	16	8	103	
200	810	500	5,0	300	60	75	M8	37,0	15	28	16	8	103	
200	810	600	5,0	200	60	75	M8	37,0	15	28	16	8	103	
200	1010	400	5,0	600	60	75	M8	37,0	15	28	16	8	103	
200	1010	500	5,0	500	60	75	M8	37,0	15	28	16	8	103	
200	1010	600	5,0	400	60	75	M8	37,0	15	28	16	8	103	
300	310	050	5,0	250	75	95	M10	50,0	15	20	20	10	125	
300	410	100	5,0	300	75	95	M10	50,0	15	20	20	10	125	
300	460	150	5,0	300	75	95	M10	50,0	15	20	20	10	125	
300	510	100	5,0	400	75	95	M10	50,0	15	20	20	10	125	
300	510	200	5,0	300	75	95	M10	50,0	15	20	20	10	125	
300	610	200	5,0	400	75	95	M10	50,0	15	20	20	10	125	
300	610	300	5,0	300	75	95	M10	50,0	15	20	20	10	125	
300	710	300	5,0	400	75	95	M10	50,0	15	20	20	10	125	
300	810	400	5,0	400	75	95	M10	50,0	15	20	20	10	125	
300	1010	400	5,0	600	75	95	M10	50,0	15	20	20	10	125	
300	1010	500	5,0	500	75	95	M10	50,0	15	20	20	10	125	
300	1010	600	5,0	400	75	95	M10	50,0	15	20	20	10	125	
400	510	100	5,0	400	100	125	M10	70,0	15	20	20	10	125	
400	610	200	5,0	400	100	125	M10	70,0	15	20	20	10	125	
400	710	300	5,0	400	100	125	M10	70,0	15	20	20	10	125	
400	810	200	5,0	600	100	125	M10	70,0	15	20	20	10	125	
400	810	400	5,0	400	100	125	M10	70,0	15	20	20	10	125	
400	1010	300	5,0	700	100	125	M10	70,0	15	20	20	10	125	
400	1010	400	5,0	600	100	125	M10	70,0	15	20	20	10	125	
400	1010	500	5,0	500	100	125	M10	70,0	15	20	20	10	125	
400	1210	400	5,0	800	100	125	M10	70,0	15	20	20	10	125	
400	1210	500	5,0	700	100	125	M10	70,0	15	20	20	10	125	
400	1210	600	5,0	600	100	125	M10	70,0	15	20	20	10	125	

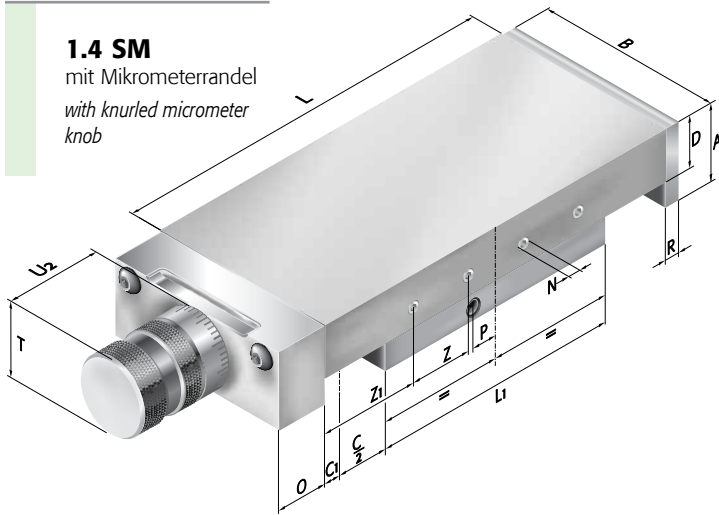

**1.4 SM**  
mit Mikrometerrandel  
with knurled micrometer  
knob

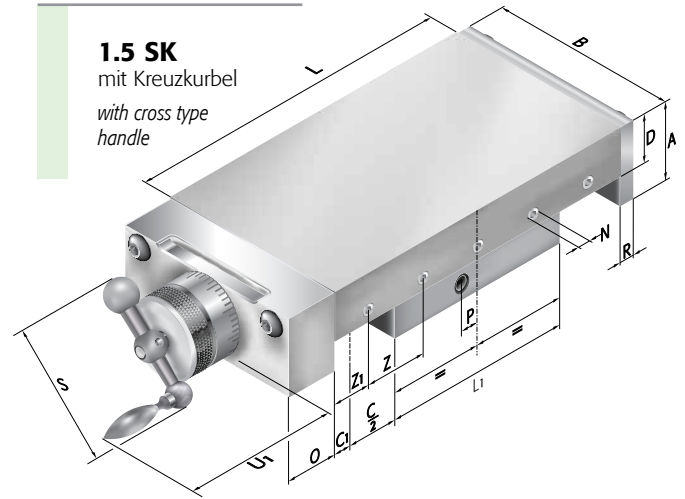

**1.5 SK**  
mit Kreuzkurbel  
with cross type  
handle

T	U1	U2	U3	V	Spindel Spindle		AR**	Mögl. Stand-Bohrbild Possible standard drilling plan		Gewicht Weight kg (GG 25)	Gewicht m. T-Nuten Weight incl. T-slots kg (GG 25)	Gewicht Weight kg (Al)	Gewicht m. T-Nuten Weight incl. T-slots kg (Al)		
					Z	Z1		Ba*	Bi*						
47,0	92	53	40	10h7	Tr16 x 2	50 x 9	30,0	1	3 x a	2 x a	26,03	33,60	12,38	15,39	
47,0	92	53	40	10h7	Tr16 x 2	50 x 9	30,0	1	3 x a	2 x a	23,13	30,70	11,23	14,24	
47,0	92	53	40	10h7	Tr16 x 2	50 x 9	30,0	2	3 x a	1 x a	20,23	27,80	10,08	13,08	
47,0	92	53	40	10h7	Tr16 x 2	50 x 11	30,0	1	4 x a	2 x a	28,45	37,51	13,52	17,12	
47,0	92	53	40	10h7	Tr16 x 2	50 x 11	30,0	2	4 x a	2 x a	25,55	34,61	12,37	15,97	
47,0	92	53	40	10h7	Tr16 x 2	50 x 13	30,0	1	5 x a	2 x a	30,88	41,42	14,67	18,86	
47,0	92	53	40	10h7	Tr16 x 2	50 x 13	30,0	2	5 x a	2 x a	27,98	38,52	13,52	17,71	
47,0	92	53	40	10h7	Tr16 x 2	50 x 15	30,0	2	6 x a	2 x a	33,31	45,34	15,83	20,60	
47,0	92	53	40	10h7	Tr16 x 2	50 x 15	30,0	2	6 x a	2 x a	30,41	42,43	14,67	19,45	
<b>47</b>	<b>92</b>	<b>53</b>	<b>40</b>	<b>10h7</b>	<b>Tr16 x 2</b>	<b>50 x 5</b>	<b>30,0</b>	<b>1</b>	<b>1 x a</b>	<b>1 x a</b>	<b>24,70</b>	<b>30,65</b>	<b>12,25</b>	<b>14,61</b>	
47	92	53	40	10h7	Tr16 x 2	50 x 7	30,0	1	2 x a	1 x a	33,24	41,10	15,85	18,97	
47	92	53	40	10h7	Tr16 x 2	50 x 7	30,0	2	2 x a	1 x a	28,61	36,47	14,01	17,13	
47	92	53	40	10h7	Tr16 x 2	50 x 9	30,0	1	2 x a	1 x a	37,16	46,94	17,63	21,51	
47	92	53	40	10h7	Tr16 x 2	50 x 9	30,0	2	2 x a	1 x a	32,53	42,31	15,79	19,67	
47	92	53	40	10h7	Tr16 x 2	50 x 11	30,0	1	3 x a	2 x a	45,70	57,40	21,23	25,87	
47	92	53	40	10h7	Tr16 x 2	50 x 11	30,0	2	3 x a	1 x a	41,07	52,76	19,39	24,03	
47	92	53	40	10h7	Tr16 x 2	50 x 11	30,0	3	3 x a	1 x a	36,44	48,13	17,55	22,19	
47	92	53	40	10h7	Tr16 x 2	50 x 13	30,0	1	4 x a	2 x a	49,62	63,23	23,00	28,41	
47	92	53	40	10h7	Tr16 x 2	50 x 13	30,0	2	4 x a	1 x a	44,99	58,60	21,16	26,57	
47	92	53	40	10h7	Tr16 x 2	50 x 13	30,0	3	4 x a	1 x a	40,36	53,97	19,32	24,73	
47	92	53	40	10h7	Tr16 x 2	50 x 15	30,0	2	4 x a	2 x a	53,54	69,07	24,78	30,94	
47	92	53	40	10h7	Tr16 x 2	50 x 15	30,0	2	4 x a	1 x a	48,91	64,43	22,94	29,10	
47	92	53	40	10h7	Tr16 x 2	50 x 15	30,0	3	4 x a	1 x a	44,28	59,80	21,10	27,26	
47	92	53	40	10h7	Tr16 x 2	50 x 19	30,0	1	5 x a	3 x a	70,63	89,99	31,99	39,68	
47	92	53	40	10h7	Tr16 x 2	50 x 19	30,0	2	5 x a	2 x a	66,00	85,36	30,15	37,84	
47	92	53	40	10h7	Tr16 x 2	50 x 19	30,0	2	5 x a	2 x a	61,37	80,83	28,31	36,00	
<b>66</b>	<b>146</b>	<b>80</b>			<b>12h7</b>	<b>Tr20 x 4</b>	<b>50 x 5</b>	<b>30,0</b>	<b>1</b>	<b>1 x a</b>	<b>-</b>	<b>52,57</b>	<b>64,31</b>	<b>26,14</b>	<b>30,81</b>
66	146	80			12h7	Tr20 x 4	50 x 7	30,0	1	1 x a	1 x a	64,56	80,10	31,26	37,43
66	146	80			12h7	Tr20 x 4	50 x 8	30,0	1	1 x a	1 x a	68,50	85,93	33,00	39,92
66	146	80			12h7	Tr20 x 4	50 x 9	30,0	1	1 x a	1 x a	80,67	100,00	38,01	45,69
66	146	80			12h7	Tr20 x 4	50 x 9	30,0	1	1 x a	1 x a	72,44	91,86	34,74	42,42
66	146	80			12h7	Tr20 x 4	50 x 11	30,0	1	2 x a	1 x a	88,56	111,67	41,50	50,68
66	146	80			12h7	Tr20 x 4	50 x 11	30,0	2	2 x a	1 x a	80,32	103,44	38,23	47,41
66	146	80			12h7	Tr20 x 4	50 x 13	30,0	1	2 x a	1 x a	96,44	123,33	44,99	55,67
66	146	80			12h7	Tr20 x 4	50 x 15	30,0	2	3 x a	1 x a	104,31	135,00	48,47	60,66
66	146	80			12h7	Tr20 x 4	50 x 19	30,0	1	3 x a	2 x a	136,53	174,80	61,98	77,18
66	146	80			12h7	Tr20 x 4	50 x 19	30,0	2	3 x a	1 x a	128,30	166,56	58,70	73,90
66	146	80			12h7	Tr20 x 4	50 x 19	30,0	2	3 x a	1 x a	120,06	158,33	55,43	70,63
<b>66</b>	<b>146</b>	<b>80</b>			<b>12h7</b>	<b>Tr20 x 4</b>	<b>50 x 9</b>	<b>30,0</b>	<b>1</b>	<b>1 x a</b>	<b>1 x a</b>	<b>142,64</b>	<b>174,92</b>	<b>63,73</b>	<b>76,55</b>
66	146	80			12h7	Tr20 x 4	50 x 11	30,0	1	1 x a	1 x a	158,30	196,91	70,08	85,42
66	146	80			12h7	Tr20 x 4	50 x 13	30,0	1	2 x a	1 x a	173,96	218,90	76,44	94,29
66	146	80			12h7	Tr20 x 4	50 x 15	30,0	1	2 x a	1 x a	215,19	266,46	92,95	113,32
66	146	80			12h7	Tr20 x 4	50 x 15	30,0	1	2 x a	1 x a	189,63	240,90	82,80	103,16
66	146	80			12h7	Tr20 x 4	50 x 19	30,0	2	2 x a	1 x a	259,30	323,23	110,74	136,13
66	146	80			12h7	Tr20 x 4	50 x 19	30,0	1	2 x a	1 x a	246,52	310,45	105,66	131,06
66	146	80			12h7	Tr20 x 4	50 x 19	30,0	2	2 x a	1 x a	233,74	297,67	100,59	125,98
66	146	80			12h7	Tr20 x 4	50 x 23	30,0	1	3 x a	2 x a	303,41	380,00	128,53	158,95
66	146	80			12h7	Tr20 x 4	50 x 23	30,0	1	3 x a	1 x a	290,63	367,22	123,45	153,87
66	146	80			12h7	Tr20 x 4	50 x 23	30,0	2	3 x a	1 x a	277,85	354,43	118,38	148,80

auf Anfrage | on request

Rollen-Schlitten sind hochpräzise Positioniermodule für die unterschiedlichsten Anwendungen. Standardschlitten sind aus GG 25 gefertigt, andere Werkstoffe sind auf Anfrage erhältlich. Alle Außenflächen sind geschliffen.

*Roller slides are highly precise positioning modules for the most different applications and tasks. The standard slides are made of grey cast iron (GG 25). Upon demand, slides made of different materials can be delivered, too. All outside surfaces are ground.*

	<p><b>RO</b></p> <p>offene Ausführung</p> <p><i>open type</i></p>
	<p><b>RE</b></p> <p>Die Baureihe RE mit Endplatten eignet sich zum Anbau von Anschlägen, Mikrometern, Zylindern etc.</p> <p><i>The RE line is equipped with end plates and suits for the attachment of stops, micrometers, cylinders etc.</i></p>
	<p><b>RS</b></p> <p>Die Baureihe RS ist mit einer Gewindespindel ausgestattet. Nähere Informationen zu den verwendeten Spindeln finden Sie auf Seite 32.</p> <p><i>The RS line is equipped with a threaded spindle. For further detailed information on the spindle types used please refer to page 32.</i></p>
	<p><b>RM</b></p> <p>Die Baureihe RM ist mit einer Mikrometer- randel mit Skalenteilung 0,02 mm ausgestattet, die Baugrößen 075 bis 200 können optional auch mit Skalenteilung 0,01 mm geliefert werden.</p> <p><i>The RM line is equipped with a knurled micrometer knob of a 0.02 mm scale gradation. Sizes 075 up to 200 can, on option, be delivered with a 0.01 mm scale gradation, too.</i></p>
	<p><b>RK</b></p> <p>Die Baureihe RK ist mit einer Kreuzkurbel, ab Baugröße 300 mit einem Handrad ausgestattet.</p> <p><i>The RK line is equipped with a cross type handle and, from size 300 on, with a hand wheel.</i></p>



**RO**  
normal montiert  
*mounted normal*

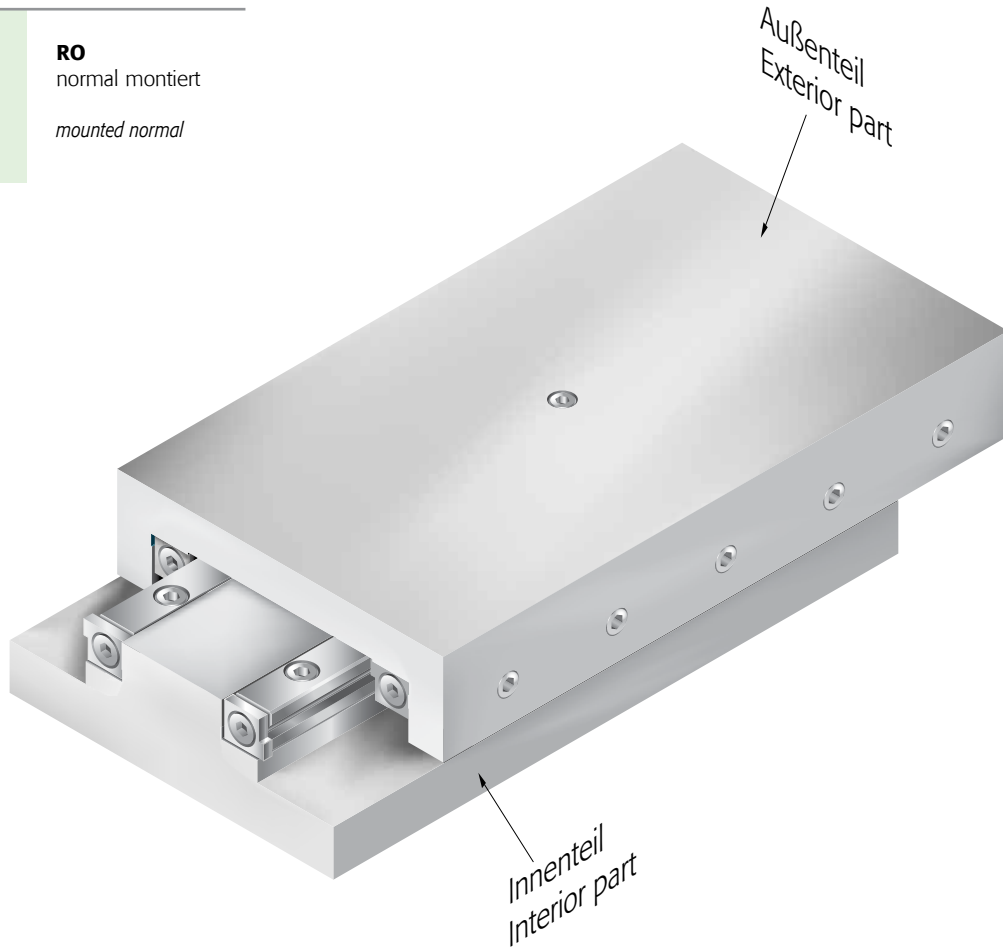

**RO**  
umgekehrt montiert  
*mounted reversed*

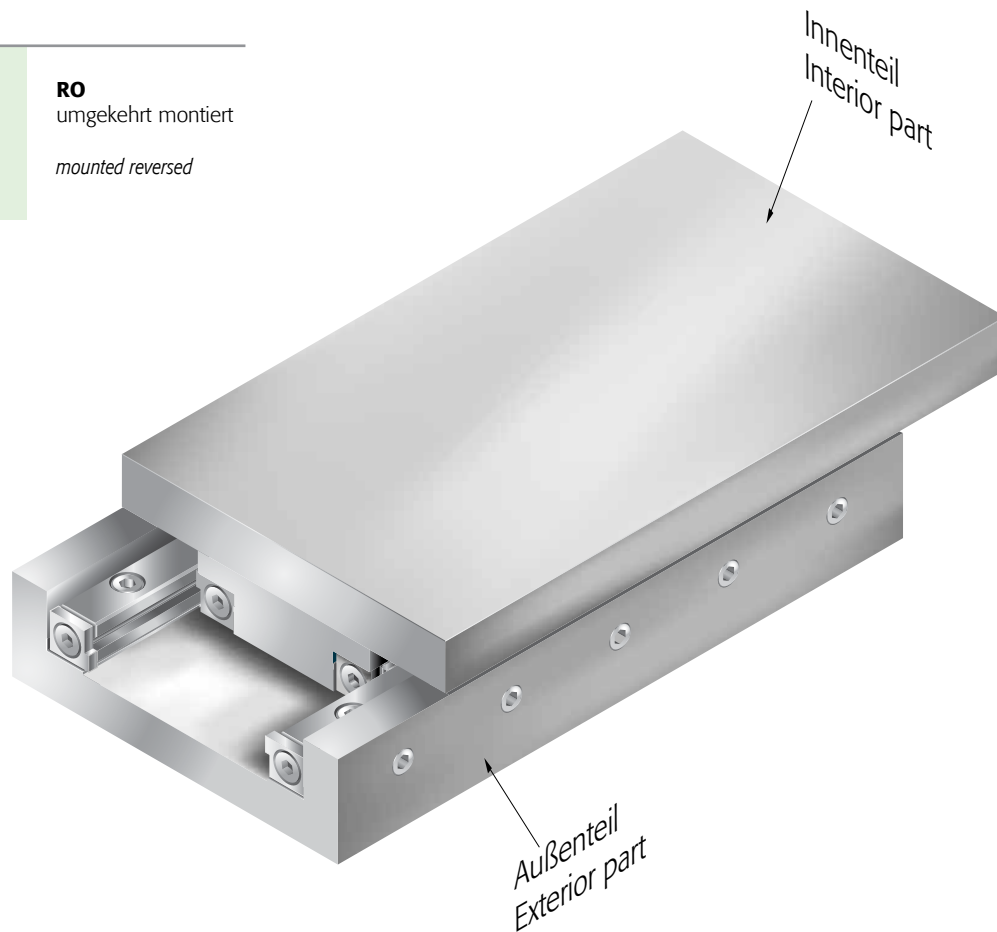

**Rollen-Schlitten, Grundmaße für alle Baureihen**  
*Roller slides, basic sizes for all lines*

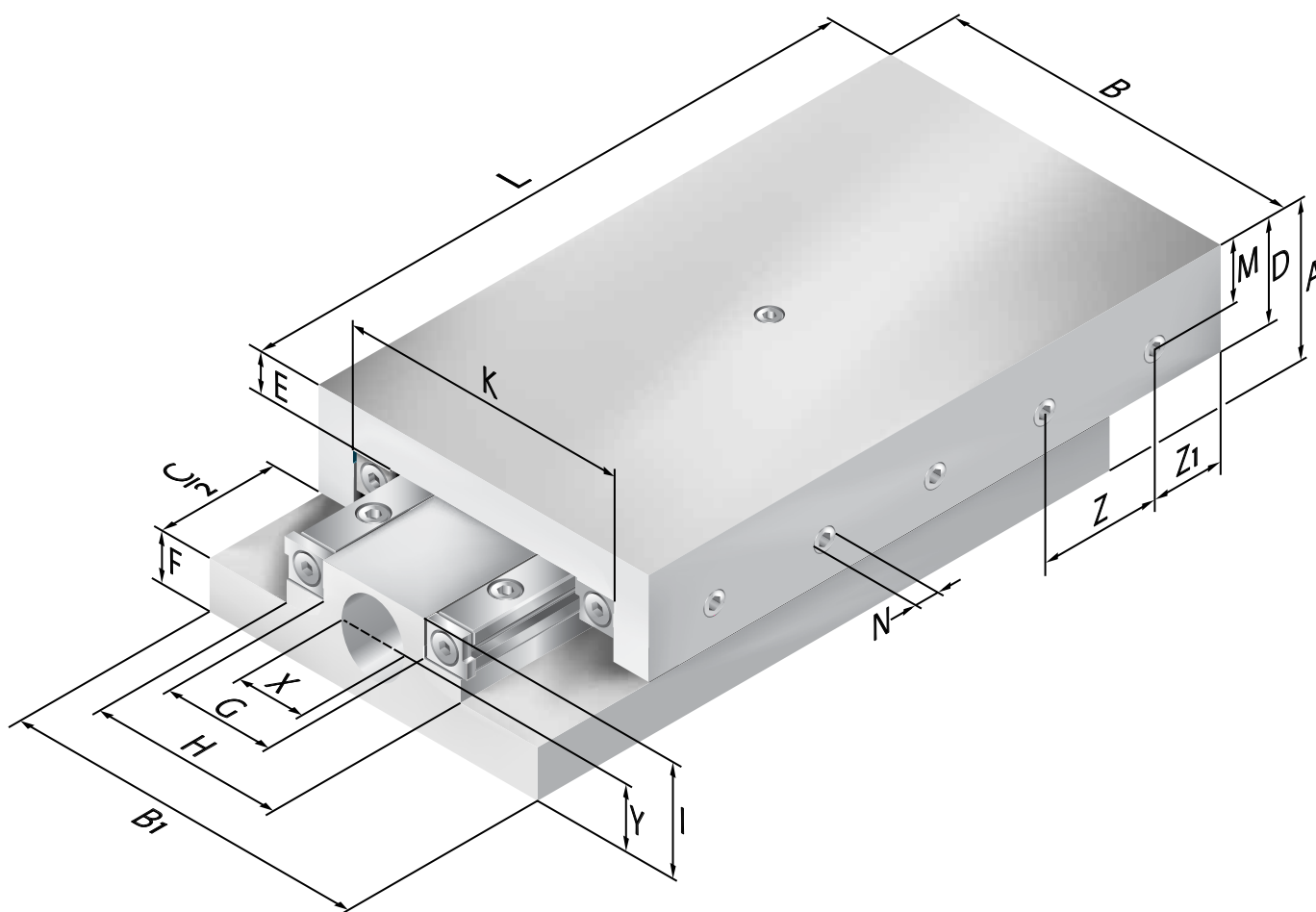

\* nicht bei RO/RE  
 \* not with RO/RE

Größe Size	B	A	B1	D	E	F	G	H	I	K	M	N	X*	Y*	Rollendurch- messer d
<b>040</b>	40	20	39,5	13,0	6,5	6,5	9,0	20,0	13,0	33,0	10,0	M3	7	9,0	2
<b>050</b>	50	25	49,5	17,0	6,5	7,5	8,5	25,0	18,0	44,5	11,0	M3	7	12,3	3
<b>060</b>	60	25	59,5	17,0	6,5	7,5	14,0	30,6	18,0	50,0	11,0	M4	9	12,3	3
<b>075</b>	75	32	74,5	21,0	8,5	10,5	23,0	39,5	23,0	59,0	13,0	M5	14	15,0	3
<b>100</b>	100	40	99,5	27,5	11,0	12,0	24,0	52,0	28,0	86,0	19,5	M6	14	19,0	6
<b>150</b>	150	50	149,0	35,5	13,0	14,0	38,0	77,5	36,5	126,0	24,5	M8	20	24,0	9
<b>200</b>	200	60	199,0	40,0	17,0	19,5	80,0	119,5	42,0	168,0	29,0	M8	20	25,0	9



**2.1 RO**

offene Ausführung

open type

**Rollen-Schlitten, Baureihe RO**  
Roller slides, RO line

Größe	Länge	Normaler Hub	Langer Hub	Höhe	Höhe m.T-Nuten		Mögliches Standard-Bohrbild		Gewicht	Gewicht mit T-Nuten	Gewicht	Gewicht mit T-Nuten
Size	Length	Standard Stroke	Long Stroke	Height	Height incl. T-slots		Possible standard drilling plan		Weight	Weight incl. T-slots	Weight	Weight incl. T-slots
B	L	C	C	A	A	Z	Z1	Ba* + Bi*	kg (GG 25)	kg (GG 25)	kg (Al)	kg (Al)
040	035	014	018	20	-	15 x 1	10	1 x a*	0,20	-	0,10	-
040	050	020	035	20	-	15 x 2	10	1 x a	0,30	-	0,15	-
040	065	026	050	20	-	15 x 3	10	2 x a	0,38	-	0,19	-
040	080	040	065	20	-	15 x 4	10	3 x a	0,47	-	0,27	-
040	095	050	085	20	-	15 x 5	10	4 x a	0,56	-	0,28	-
040	110	065	100	20	-	15 x 6	10	5 x a	0,64	-	0,32	-
040	125	080	120	20	-	15 x 7	10	6 x a	0,73	-	0,37	-
050	055	020	040	25	35	25 x 1	15	1 x a	0,44	0,60	0,24	0,30
050	080	030	060	25	35	25 x 2	15	2 x a	0,64	0,90	0,35	0,45
050	105	040	080	25	35	25 x 3	15	3 x a	0,84	1,15	0,46	0,58
050	130	050	100	25	35	25 x 4	15	4 x a	1,04	1,43	0,57	0,72
050	155	060	120	25	35	25 x 5	15	5 x a	1,25	1,70	0,68	0,87
050	180	075	150	25	35	25 x 6	15	6 x a	1,44	1,97	0,79	1,00
050	205	100	180	25	35	25 x 7	15	7 x a	1,65	2,25	0,90	1,14
060	055	020	040	25	35	25 x 1	15	1 x a	0,53	0,73	0,28	0,36
060	080	030	060	25	35	25 x 2	15	2 x a	0,77	1,07	0,41	0,54
060	105	040	080	25	35	25 x 3	15	2 x a	1,02	1,40	0,54	0,69
060	130	050	100	25	35	25 x 4	15	3 x a	1,27	1,73	0,67	0,86
060	155	060	120	25	35	25 x 5	15	4 x a	1,50	2,07	0,80	1,02
060	180	075	150	25	35	25 x 6	15	5 x a	1,75	2,41	0,94	1,20
060	205	100	180	25	35	25 x 7	15	5 x a	2,00	2,75	1,06	1,36
060	255	125	200	25	35	25 x 9	15	7 x a	2,47	3,41	1,32	1,69
075	080	030	060	32	44	25 x 2	15	1 x a	1,23	1,69	0,62	0,851
075	105	040	080	32	44	25 x 3	15	1 x a	1,61	2,23	0,82	1,06
075	130	050	100	32	44	25 x 4	15	1 x a	2,00	2,76	1,02	1,32
075	155	060	120	32	44	25 x 5	15	2 x a	2,39	3,29	1,22	1,57
075	180	075	150	32	44	25 x 6	15	2 x a	2,77	3,82	1,40	1,82
075	205	100	180	32	44	25 x 7	15	3 x a	3,16	4,35	1,60	2,08
075	255	125	200	32	44	25 x 9	15	3 x a	3,93	5,42	2,00	2,59
075	305	150	250	32	44	25 x 11	15	4 x a	4,70	6,47	2,39	3,09
100	110	030	050	40	50	50 x 1	30	1 x a	2,92	3,57	1,59	1,84
100	160	060	105	40	50	50 x 2	30	1 x a	4,28	5,22	2,34	2,71
100	210	080	160	40	50	50 x 3	30	2 x a	5,65	6,88	3,10	3,59
100	260	110	210	40	50	50 x 4	30	2 x a	7,00	8,54	3,85	4,45
100	310	160	260	40	50	50 x 5	30	3 x a	8,37	10,20	4,61	5,33
100	360	210	310	40	50	50 x 6	30	4 x a	9,73	11,85	5,36	6,20
100	410	260	360	40	50	50 x 7	30	4 x a	11,10	13,51	6,12	7,08
100	510	310	460	40	50	50 x 9	30	5 x a	13,82	16,83	7,63	8,82
150	160	050	075	50	66	100 x 1	30	1 x a	8,63	11,13	4,87	5,86
150	210	100	160	50	66	100 x 1	55	1 x a	10,79	13,92	6,09	7,33
150	310	150	260	50	66	100 x 2	55	2 x a	15,99	20,61	9,06	10,89
150	410	200	360	50	66	100 x 3	55	3 x a	21,19	27,29	12,01	14,44
150	510	250	460	50	66	100 x 4	55	3 x a	26,39	33,99	14,98	17,99
150	610	300	560	50	66	100 x 5	55	4 x a	31,58	40,67	17,93	21,54
150	710	350	660	50	66	100 x 6	55	5 x a	36,78	47,36	20,90	25,10
150	810	400	760	50	66	100 x 7	55	6 x a	41,99	54,15	23,86	28,65
200	210	100	160	60	75	100 x 1	55	1 x a	17,45	21,49	8,74	10,34
200	310	150	260	60	75	100 x 2	55	1 x a	25,83	31,78	12,96	15,33
200	410	200	360	60	75	100 x 3	55	2 x a	34,19	42,07	17,18	20,31
200	510	250	460	60	75	100 x 4	55	2 x a	42,56	52,37	21,40	25,29
200	610	300	560	60	75	100 x 5	55	3 x a	50,93	62,65	25,62	30,27
200	710	350	660	60	75	100 x 6	55	4 x a	59,30	72,95	29,84	35,26
200	810	400	760	60	75	100 x 7	55	4 x a	67,68	83,24	34,07	40,25



**2.2 RE**  
mit Endplatten  
with end plates

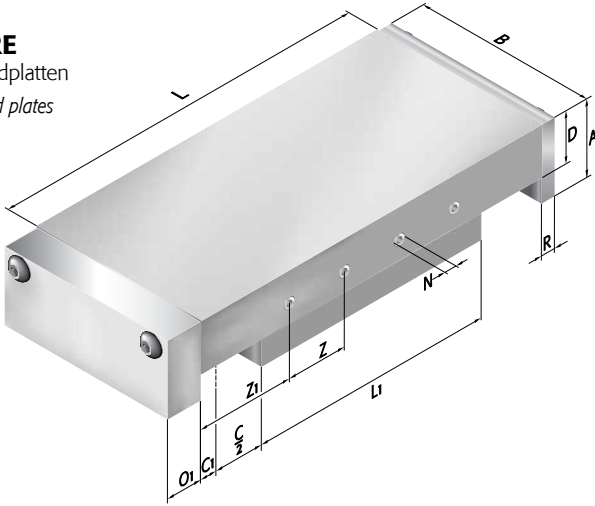

**2.3 RS**  
mit Spindel  
with spindle

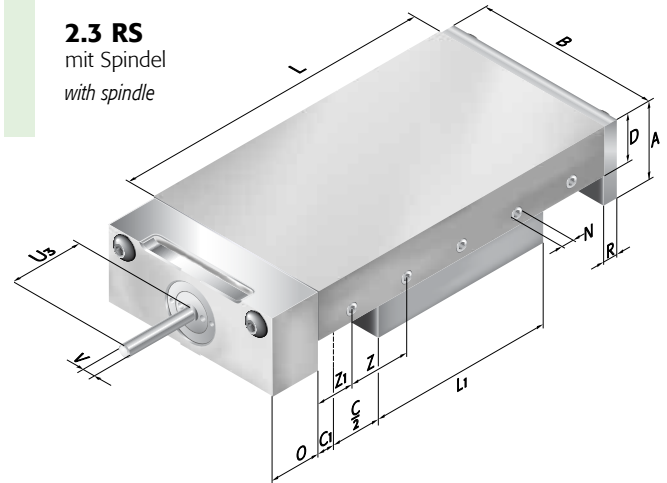

Maßtabelle Baugrößen 40 - 100 | Size table, sizes 40 - 100

Größe Size	Länge Length	Hub Stroke			Höhe Height	Höhe m. T-Nuten Height incl. T-slots		N	D	O	O1	R	S	T
B	L	C	C1	L1	A	A	N	D	O	O1	R	S	T	
<b>040</b>	<b>045</b>	<b>010</b>	<b>2,5</b>	<b>030</b>	<b>20</b>	–	<b>M3</b>	<b>13,0</b>	<b>12</b>	<b>12</b>	<b>3</b>	–	<b>16,0</b>	
040	070	020	2,5	045	20	–	M3	13,0	12	12	3	–	16,0	
040	080	030	2,5	045	20	–	M3	13,0	12	12	3	–	16,0	
040	090	025	2,5	060	20	–	M3	13,0	12	12	3	–	16,0	
040	090	040	2,5	045	20	–	M3	13,0	12	12	3	–	16,0	
040	120	040	2,5	075	20	–	M3	13,0	12	12	3	–	16,0	
040	130	050	2,5	075	20	–	M3	13,0	12	12	3	–	16,0	
040	155	060	2,5	090	20	–	M3	13,0	12	12	3	–	16,0	
040	185	075	2,5	105	20	–	M3	13,0	12	12	3	–	16,0	
<b>050</b>	<b>075</b>	<b>020</b>	<b>2,5</b>	<b>050</b>	<b>25</b>	<b>35</b>	<b>M3</b>	<b>17,0</b>	<b>19</b>	<b>14</b>	<b>6</b>	<b>47</b>	<b>23,5</b>	
050	105	025	2,5	075	25	35	M3	17,0	19	14	6	47	23,5	
050	130	025	2,5	100	25	35	M3	17,0	19	14	6	47	23,5	
050	155	025	2,5	125	25	35	M3	17,0	19	14	6	47	23,5	
050	155	050	2,5	100	25	35	M3	17,0	19	14	6	47	23,5	
050	180	050	2,5	125	25	35	M3	17,0	19	14	6	47	23,5	
050	180	075	2,5	100	25	35	M3	17,0	19	14	6	47	23,5	
050	205	050	2,5	150	25	35	M3	17,0	19	14	6	47	23,5	
050	205	075	2,5	125	25	35	M3	17,0	19	14	6	47	23,5	
<b>060</b>	<b>075</b>	<b>020</b>	<b>2,5</b>	<b>050</b>	<b>25</b>	<b>35</b>	<b>M4</b>	<b>17,0</b>	<b>19</b>	<b>14</b>	<b>6</b>	<b>47</b>	<b>23,5</b>	
060	105	025	2,5	075	25	35	M4	17,0	19	14	6	47	23,5	
060	130	025	2,5	100	25	35	M4	17,0	19	14	6	47	23,5	
060	155	025	2,5	125	25	35	M4	17,0	19	14	6	47	23,5	
060	155	050	2,5	100	25	35	M4	17,0	19	14	6	47	23,5	
060	180	050	2,5	125	25	35	M4	17,0	19	14	6	47	23,5	
060	180	075	2,5	100	25	35	M4	17,0	19	14	6	47	23,5	
060	205	050	2,5	150	25	35	M4	17,0	19	14	6	47	23,5	
060	205	075	2,5	125	25	35	M4	17,0	19	14	6	47	23,5	
060	255	050	2,5	200	25	35	M4	17,0	19	14	6	47	23,5	
060	255	100	2,5	150	25	35	M4	17,0	19	14	6	47	23,5	
<b>075</b>	<b>105</b>	<b>025</b>	<b>2,5</b>	<b>075</b>	<b>32</b>	<b>44</b>	<b>M5</b>	<b>21,0</b>	<b>21</b>	<b>15</b>	<b>6</b>	<b>47</b>	<b>30,0</b>	
075	130	025	2,5	100	32	44	M5	21,0	21	15	6	47	30,0	
075	155	025	2,5	125	32	44	M5	21,0	21	15	6	47	30,0	
075	155	050	2,5	100	32	44	M5	21,0	21	15	6	47	30,0	
075	180	050	2,5	125	32	44	M5	21,0	21	15	6	47	30,0	
075	180	075	2,5	100	32	44	M5	21,0	21	15	6	47	30,0	
075	205	050	2,5	150	32	44	M5	21,0	21	15	6	47	30,0	
075	205	075	2,5	125	32	44	M5	21,0	21	15	6	47	30,0	
075	255	050	2,5	200	32	44	M5	21,0	21	15	6	47	30,0	
075	255	100	2,5	150	32	44	M5	21,0	21	15	6	47	30,0	
075	305	050	2,5	250	32	44	M5	21,0	21	15	6	47	30,0	
075	305	100	2,5	200	32	44	M5	21,0	21	15	6	47	30,0	
075	305	125	2,5	175	32	44	M5	21,0	21	15	6	47	30,0	
<b>100</b>	<b>135</b>	<b>025</b>	<b>5,0</b>	<b>100</b>	<b>40</b>	<b>50</b>	<b>M6</b>	<b>27,5</b>	<b>21</b>	<b>15</b>	<b>6</b>	<b>47</b>	<b>30,0</b>	
100	160	050	5,0	100	40	50	M6	27,5	21	15	6	47	30,0	
100	210	050	5,0	150	40	50	M6	27,5	21	15	6	47	30,0	
100	260	050	5,0	200	40	50	M6	27,5	21	15	6	47	30,0	
100	260	100	5,0	150	40	50	M6	27,5	21	15	6	47	30,0	



**2.4 RM**  
mit Mikrometerrandel  
with knurled micrometer  
knob

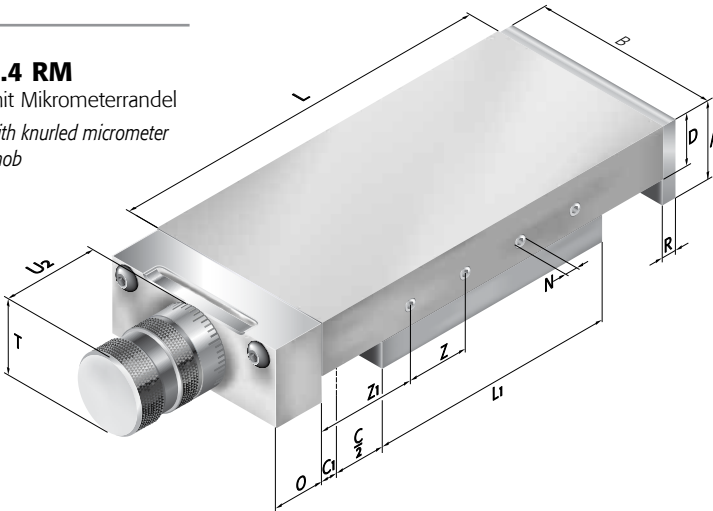

**2.5 RK**  
mit Kreuzkurbel  
with cross type  
handle

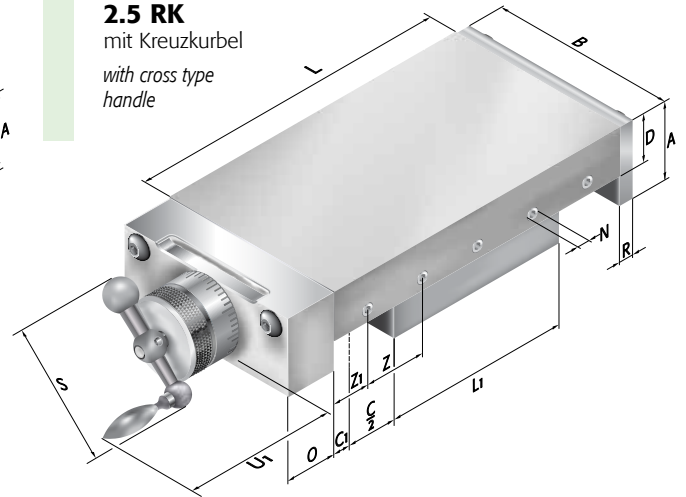

U1	U2	U3	V	Spindel Spindle	Z	Z1	Mögl. Stand.-Bohrbild Possible standard drilling plan Ba*	Bi*	Gewicht Weight kg (GG 25)	Gewicht mit T-Nuten Weight incl. T-slots kg (GG 25)	Gewicht Weight kg (Al)	Gewicht mit T-Nuten Weight incl. T-slots kg (Al)
-	24	-	-	M5 x 0,5	15 x 1	15,0	1 x a*	1 x a	0,34	-	0,23	-
-	24	-	-	M5 x 0,5	15 x 2	20,0	1 x a	2 x a	0,45	-	0,28	-
-	24	-	-	M5 x 0,5	15 x 2	25,0	3 x a	2 x a	0,48	-	0,30	-
-	24	-	-	M5 x 0,5	15 x 3	22,5	4 x a	3 x a	0,55	-	0,34	-
-	24	-	-	M5 x 0,5	15 x 2	30,0	3 x a	2 x a	0,50	-	0,31	-
-	24	-	-	M5 x 0,5	15 x 4	30,0	5 x a	4 x a	0,68	-	0,40	-
-	24	-	-	M5 x 0,5	15 x 4	35,0	5 x a	4 x a	0,70	-	0,41	-
-	24	-	-	M5 x 0,5	15 x 5	40,0	8 x a	5 x a	0,82	-	0,47	-
-	24	-	-	M5 x 0,5	15 x 6	47,5	9 x a	6 x a	0,94	-	0,52	-
51	31	-	-	M6 x 1,0	25 x 1	25,0	2 x a	1 x a	0,84	1,08	0,59	0,68
51	31	-	-	M6 x 1,0	25 x 2	27,5	3 x a	2 x a	1,02	1,33	0,69	0,81
51	31	-	-	M6 x 1,0	25 x 3	27,5	4 x a	3 x a	1,23	1,60	0,80	0,95
51	31	-	-	M6 x 1,0	25 x 4	27,5	5 x a	4 x a	1,44	1,87	0,91	1,09
51	31	-	-	M6 x 1,0	25 x 3	40,0	5 x a	3 x a	1,31	1,76	0,84	1,02
51	31	-	-	M6 x 1,0	25 x 4	40,0	6 x a	4 x a	1,50	2,03	1,02	1,16
51	31	-	-	M6 x 1,0	25 x 3	52,5	6 x a	3 x a	1,39	1,91	0,95	1,08
51	31	-	-	M6 x 1,0	25 x 5	40,0	7 x a	5 x a	1,71	2,31	1,06	1,30
51	31	-	-	M6 x 1,0	25 x 4	52,5	7 x a	4 x a	1,60	2,19	0,99	1,22
51	31	-	-	M6 x 1,0	25 x 2	27,5	2 x a	1 x a	1,20	1,58	0,79	0,94
51	31	-	-	M6 x 1,0	25 x 3	27,5	3 x a	2 x a	1,45	1,91	0,91	1,10
51	31	-	-	M6 x 1,0	25 x 4	27,5	4 x a	3 x a	1,70	2,24	1,03	1,26
51	31	-	-	M6 x 1,0	25 x 3	40,0	4 x a	2 x a	1,55	2,11	0,96	1,19
51	31	-	-	M6 x 1,0	25 x 4	40,0	5 x a	3 x a	1,80	2,45	1,10	1,36
51	31	-	-	M6 x 1,0	25 x 3	52,5	5 x a	2 x a	1,66	2,31	1,08	1,28
51	31	-	-	M6 x 1,0	25 x 5	40,0	5 x a	4 x a	2,05	2,79	1,23	1,52
51	31	-	-	M6 x 1,0	25 x 4	52,5	5 x a	3 x a	1,91	2,65	1,15	1,44
51	31	-	-	M6 x 1,0	25 x 7	40,0	7 x a	5 x a	2,53	3,45	1,49	1,85
51	31	-	-	M6 x 1,0	25 x 5	65,0	7 x a	4 x a	2,26	3,18	1,33	1,69
54	38	31	5h7	M10 x 1,0	25 x 2	27,5	1 x a	1 x a	2,00	2,60	1,30	1,54
54	38	31	5h7	M10 x 1,0	25 x 3	27,5	1 x a	1 x a	2,39	3,14	1,50	1,80
54	38	31	5h7	M10 x 1,0	25 x 4	27,5	1 x a	1 x a	2,77	3,67	1,70	2,05
54	38	31	5h7	M10 x 1,0	25 x 3	40,0	1 x a	1 x a	2,58	3,47	1,59	1,95
54	38	31	5h7	M10 x 1,0	25 x 4	40,0	2 x a	1 x a	2,96	4,00	1,78	2,20
54	38	31	5h7	M10 x 1,0	25 x 3	52,5	2 x a	1 x a	2,76	3,88	1,68	2,10
54	38	31	5h7	M10 x 1,0	25 x 5	40,0	2 x a	2 x a	3,35	4,53	1,98	2,45
54	38	31	5h7	M10 x 1,0	25 x 4	52,5	2 x a	1 x a	3,15	4,34	1,88	2,35
54	38	31	5h7	M10 x 1,0	25 x 7	40,0	3 x a	3 x a	4,12	5,59	2,38	2,96
54	38	31	5h7	M10 x 1,0	25 x 5	65,0	3 x a	2 x a	3,73	5,21	2,17	2,76
54	38	31	5h7	M10 x 1,0	25 x 9	40,0	4 x a	3 x a	4,89	6,65	2,77	3,47
54	38	31	5h7	M10 x 1,0	25 x 7	65,0	4 x a	3 x a	4,50	6,26	2,56	3,26
54	38	31	5h7	M10 x 1,0	25 x 6	77,5	4 x a	2 x a	4,32	6,07	2,46	3,16
54	38	31	5h7	M10 x 1,0	50 x 1	42,5	1 x a	1 x a	3,94	4,73	2,47	2,78
54	38	31	5h7	M10 x 1,0	50 x 1	55,0	1 x a	1 x a	4,22	5,14	2,59	2,96
54	38	31	5h7	M10 x 1,0	50 x 2	55,0	1 x a	1 x a	5,58	7,20	3,35	3,84
54	38	31	5h7	M10 x 1,0	50 x 3	55,0	2 x a	2 x a	6,94	8,44	4,10	4,70
54	38	31	5h7	M10 x 1,0	50 x 2	80,0	2 x a	1 x a	6,13	7,63	3,60	4,20



**2.2 RE**  
mit Endplatten  
with end plates

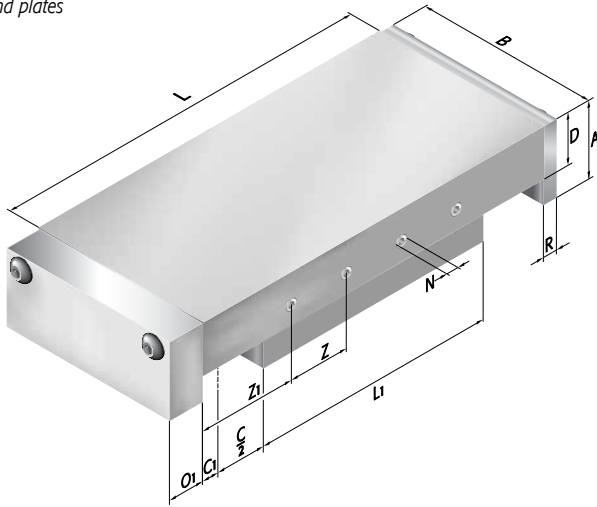

**2.3 RS**  
mit Spindel  
with spindle

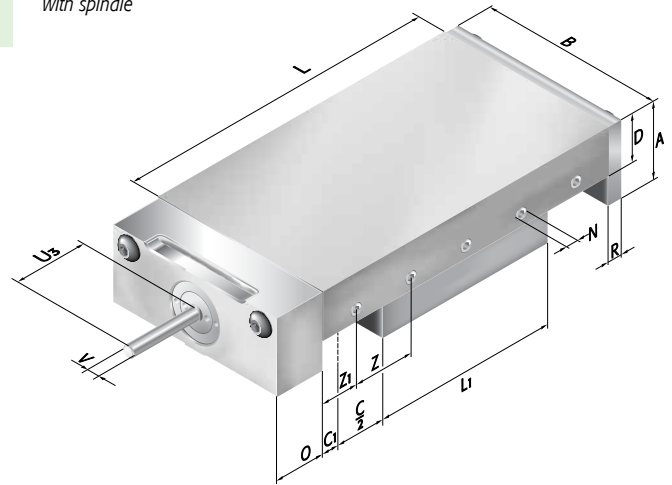

Maßtabelle Baugrößen 150 - 300 | Size table, sizes 150 - 300

Größe Size	Länge Length	Hub Stroke			Höhe Height	Höhe m. T-Nuten Height incl. T-slots							
B	L	C	C1	L1	A	A	N	D	O	O1	R	S	T
100	310	050	5,0	250	40	50	M6	27,5	21	15	6	47	30,0
100	310	100	5,0	200	40	50	M6	27,5	21	15	6	47	30,0
100	360	100	5,0	250	40	50	M6	27,5	21	15	6	47	30,0
100	360	150	5,0	200	40	50	M6	27,5	21	15	6	47	30,0
100	410	100	5,0	300	40	50	M6	27,5	21	15	6	47	30,0
100	410	150	5,0	250	40	50	M6	27,5	21	15	6	47	30,0
100	510	100	5,0	400	40	50	M6	27,5	21	15	6	47	30,0
100	510	150	5,0	350	40	50	M6	27,5	21	15	6	47	30,0
100	510	200	5,0	300	40	50	M6	27,5	21	15	6	47	30,0
150	210	050	5,0	150	50	66	M8	35,5	28	16	8	103	47
150	260	050	5,0	200	50	66	M8	35,5	28	16	8	103	47
150	310	100	5,0	200	50	66	M8	35,5	28	16	8	103	47
150	360	150	5,0	200	50	66	M8	35,5	28	16	8	103	47
150	410	100	5,0	300	50	66	M8	35,5	28	16	8	103	47
150	460	150	5,0	300	50	66	M8	35,5	28	16	8	103	47
150	510	100	5,0	400	50	66	M8	35,5	28	16	8	103	47
150	510	200	5,0	300	50	66	M8	35,5	28	16	8	103	47
150	610	200	5,0	400	50	66	M8	35,5	28	16	8	103	47
150	610	300	5,0	300	50	66	M8	35,5	28	16	8	103	47
150	710	200	5,0	500	50	66	M8	35,5	28	16	8	103	47
150	710	300	5,0	400	50	66	M8	35,5	28	16	8	103	47
150	810	200	5,0	600	50	66	M8	35,5	28	16	8	103	47
150	810	300	5,0	500	50	66	M8	35,5	28	16	8	103	47
150	810	400	5,0	400	50	66	M8	35,5	28	16	8	103	47
200	260	050	5,0	200	60	75	M8	40,0	28	16	8	103	47
200	310	100	5,0	200	60	75	M8	40,0	28	16	8	103	47
200	360	150	5,0	200	60	75	M8	40,0	28	16	8	103	47
200	410	100	5,0	300	60	75	M8	40,0	28	16	8	103	47
200	460	150	5,0	300	60	75	M8	40,0	28	16	8	103	47
200	510	100	5,0	400	60	75	M8	40,0	28	16	8	103	47
200	510	200	5,0	300	60	75	M8	40,0	28	16	8	103	47
200	610	200	5,0	400	60	75	M8	40,0	28	16	8	103	47
200	610	300	5,0	300	60	75	M8	40,0	28	16	8	103	47
200	710	200	5,0	500	60	75	M8	40,0	28	16	8	103	47
200	710	300	5,0	400	60	75	M8	40,0	28	16	8	103	47
200	810	200	5,0	600	60	75	M8	40,0	28	16	8	103	47
200	810	300	5,0	500	60	75	M8	40,0	28	16	8	103	47
200	810	400	5,0	400	60	75	M8	40,0	28	16	8	103	47

Standardausführung aus Grauguss 25  
Standard type made of grey cast iron (GG 25)

**2.4 RM**  
mit Mikrometerrandel  
with knurled micrometer  
knob

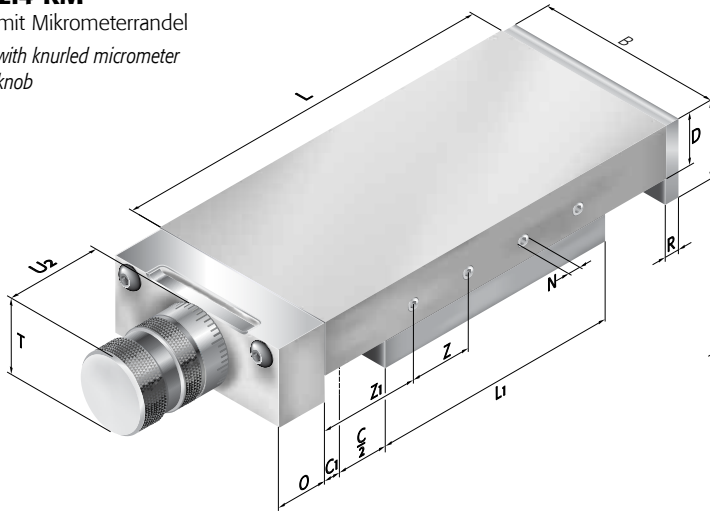

**2.5 RK**  
mit Kreuzkurbel  
with cross type  
handle

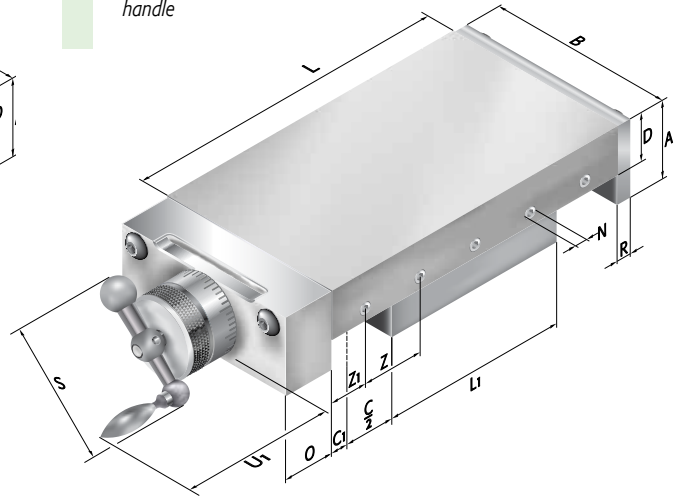

U1	U2	U3	V	Spindel Spindle	Mögl. Stand.-Bohrbild Possible standard drilling plan	Gewicht Weight	Gewicht mit T-Nuten Weight incl. T-slots	Gewicht Weight	Gewicht mit T-Nuten Weight incl. T-slots			
				Z	Z1	Ba*	Bi*	kg (GG 25)	kg (GG 25)	kg (Al)	kg (Al)	
54	38	31	5h7	M10 x 1,0	50 x 4	55,0	3 x a	2 x a	8,31	10,10	4,86	5,58
54	38	31	5h7	M10 x 1,0	50 x 3	80,0	3 x a	2 x a	7,49	9,29	4,36	5,07
54	38	31	5h7	M10 x 1,0	50 x 4	80,0	3 x a	2 x a	8,85	10,93	5,11	5,94
54	38	31	5h7	M10 x 1,0	50 x 3	105,0	3 x a	2 x a	8,04	10,12	4,61	5,43
54	38	31	5h7	M10 x 1,0	50 x 5	80,0	4 x a	3 x a	10,22	12,59	5,87	6,81
54	38	31	5h7	M10 x 1,0	50 x 4	105,0	4 x a	2 x a	9,41	11,78	5,37	6,31
54	38	31	5h7	M10 x 1,0	50 x 7	80,0	5 x a	4 x a	12,94	15,89	7,39	8,56
54	38	31	5h7	M10 x 1,0	50 x 6	105,0	5 x a	3 x a	12,13	15,08	6,88	8,05
54	38	31	5h7	M10 x 1,0	50 x 5	130,0	5 x a	3 x a	11,32	14,27	6,37	7,54
<b>92</b>	<b>53</b>	<b>40</b>	<b>10h7</b>	<b>Tr 16 x 2</b>	<b>100 x 1</b>	<b>55,0</b>	<b>1 x a</b>	<b>1 x a</b>	<b>10,68</b>	<b>13,78</b>	<b>6,58</b>	<b>7,81</b>
92	53	40	10h7	Tr 16 x 2	100 x 1	80,0	1 x a	1 x a	13,91	17,74	8,69	10,21
92	53	40	10h7	Tr 16 x 2	100 x 1	105,0	2 x a	1 x a	14,94	19,50	9,16	10,98
92	53	40	10h7	Tr 16 x 2	100 x 1	130,0	2 x a	1 x a	15,94	21,25	9,63	11,74
92	53	40	10h7	Tr 16 x 2	100 x 2	105,0	3 x a	2 x a	20,12	26,17	12,12	14,52
92	53	40	10h7	Tr 16 x 2	100 x 2	130,0	3 x a	2 x a	21,14	27,92	12,59	15,28
92	53	40	10h7	Tr 16 x 2	100 x 3	105,0	3 x a	2 x a	25,33	32,85	15,08	18,07
92	53	40	10h7	Tr 16 x 2	100 x 2	155,0	3 x a	2 x a	22,16	29,68	13,07	16,05
92	53	40	10h7	Tr 16 x 2	100 x 3	155,0	4 x a	2 x a	27,35	36,35	16,02	19,59
92	53	40	10h7	Tr 16 x 2	100 x 3	155,0	4 x a	2 x a	24,19	33,18	14,00	17,58
92	53	40	10h7	Tr 16 x 2	100 x 4	155,0	5 x a	3 x a	32,55	43,02	18,99	23,14
92	53	40	10h7	Tr 16 x 2	100 x 3	205,0	5 x a	2 x a	29,39	39,86	16,97	21,13
92	53	40	10h7	Tr 16 x 2	100 x 5	155,0	6 x a	4 x a	37,76	49,70	21,95	26,70
92	53	40	10h7	Tr 16 x 2	100 x 4	205,0	6 x a	3 x a	34,59	47,54	19,93	24,68
92	53	40	10h7	Tr 16 x 2	100 x 5	155,0	6 x a	2 x a	31,43	43,37	17,92	22,66
<b>92</b>	<b>53</b>	<b>40</b>	<b>10h7</b>	<b>Tr 16 x 2</b>	<b>100 x 1</b>	<b>80,0</b>	<b>1 x a</b>	<b>1 x a</b>	<b>21,59</b>	<b>26,54</b>	<b>12,01</b>	<b>13,98</b>
92	53	40	10h7	Tr 16 x 2	100 x 1	105,0	1 x a	1 x a	23,21	29,12	12,73	15,08
92	53	40	10h7	Tr 16 x 2	100 x 1	130,0	2 x a	1 x a	24,82	31,69	13,44	16,16
92	53	40	10h7	Tr 16 x 2	100 x 2	105,0	2 x a	1 x a	31,57	39,39	16,95	20,05
92	53	40	10h7	Tr 16 x 2	100 x 2	130,0	2 x a	1 x a	33,19	41,96	17,65	21,14
92	53	40	10h7	Tr 16 x 2	100 x 3	105,0	2 x a	2 x a	39,95	49,67	21,17	25,03
92	53	40	10h7	Tr 16 x 2	100 x 2	155,0	2 x a	1 x a	34,81	44,53	18,37	22,23
92	53	40	10h7	Tr 16 x 2	100 x 3	155,0	3 x a	2 x a	43,18	54,81	22,58	27,20
92	53	40	10h7	Tr 16 x 2	100 x 3	155,0	3 x a	1 x a	38,04	49,67	19,78	24,40
92	53	40	10h7	Tr 16 x 2	100 x 4	155,0	4 x a	2 x a	51,55	65,09	26,81	32,19
92	53	40	10h7	Tr 16 x 2	100 x 3	205,0	4 x a	2 x a	46,41	59,95	24,01	29,39
92	53	40	10h7	Tr 16 x 2	100 x 5	155,0	4 x a	3 x a	59,92	75,37	31,03	37,17
92	53	40	10h7	Tr 16 x 2	100 x 4	205,0	4 x a	2 x a	54,79	70,23	28,23	34,37
92	53	40	10h7	Tr 16 x 2	100 x 5	155,0	4 x a	2 x a	49,65	65,09	25,43	31,57



**RA**

**Rollengelagerter Schlitten in abgedichteter Ausführung.**

Die Standardausführung ist mit einer Spaltdichtung (ca. 0,5 mm) versehen. Sonderausführungen mit Filz- oder Nylon-Abstreifern sind möglich.

**Roller slides, sealed models**

The standard type is equipped with a gap seal (approx. 0.5 mm). Special types with felt or nylon scrapers are possible, too.

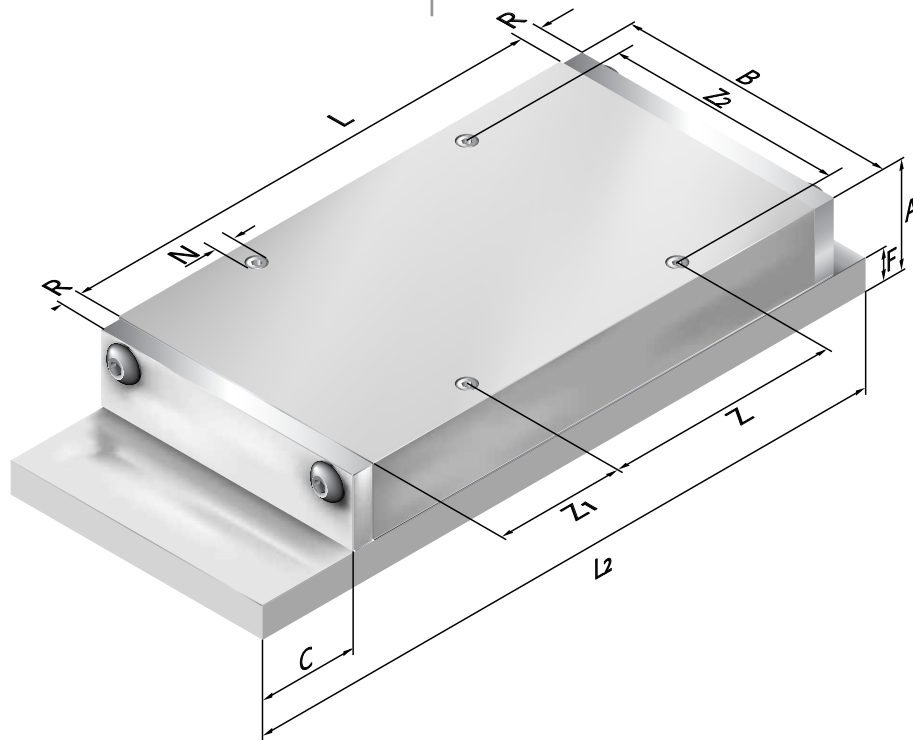

Größe Size	Länge Length	Hub Stroke	Höhe Height	
B	L	C	L1	A
040	045	010	034	20
040	070	020	049	20
040	080	030	049	20
040	090	025	064	20
040	090	040	049	20
040	120	040	079	20
040	130	050	079	20
040	155	060	094	20
040	185	075	109	20
050	075	020	054	25
050	105	025	079	25
050	130	025	104	25
050	155	025	129	25
050	155	050	104	25
050	180	050	129	25
050	180	075	104	25
050	205	050	154	25
050	205	075	129	25
060	075	020	054	25
060	105	025	079	25
060	130	025	104	25
060	155	025	129	25
060	155	050	104	25
060	180	050	129	25
060	180	075	104	25
060	205	050	154	25
060	205	075	129	25
060	255	025	104	25
060	255	050	129	25
060	255	100	154	25
075	105	025	079	32
075	130	025	104	32
075	155	025	129	32
075	155	050	104	32
075	180	050	129	32
075	180	075	104	32
075	205	050	154	32
075	205	075	129	32
075	255	050	204	32
075	255	100	154	32
075	305	050	254	32
075	305	100	204	32
075	305	125	179	32
100	135	025	108	40
100	160	050	108	40
100	210	050	158	40
100	260	050	208	40
100	260	100	158	40
100	310	050	258	40
100	310	100	208	40
100	360	100	258	40
100	360	150	208	40
100	410	100	308	40
150	210	050	158	50
150	260	050	208	50
150	310	100	208	50
150	360	150	208	50
150	410	100	308	50
150	460	150	308	50
150	510	100	408	50
150	510	200	308	50
150	610	200	408	50
200	260	050	208	60
200	310	100	208	60
200	360	150	208	60
200	410	100	308	60
200	460	150	308	60
200	510	100	408	60
200	510	200	308	60
200	610	200	408	60





### 3. Rollen-Schlitten in abgedichteter Ausführung | Roller slides, sealed models

Höhe m. T-Nuten Height incl. T-slots								Mögl. Stand.-Bohrbild Possible standard drilling plan		Gewicht Weight	Gewicht mit T-Nuten Weight incl. T-slots	Gewicht Weight	Gewicht mit T-Nuten Weight incl. T-slots
	A	L2	F	N	R	Z	Z1	Z2	Ba*	Bi*	kg (GG 25)	kg (GG 25)	kg (Al)
–	<b>061</b>	<b>6,5</b>	<b>6</b>	<b>3</b>	<b>15 x 1</b>	<b>15,0</b>	<b>28,0</b>	<b>1 x a*</b>	<b>3 x a</b>	<b>0,32</b>	–	<b>0,17</b>	–
–	096	6,5	6	3	15 x 2	20,0	28,0	3 x a	5 x a	0,46	–	0,23	–
–	116	6,5	6	3	15 x 2	25,0	28,0	3 x a	7 x a	0,52	–	0,26	–
–	121	6,5	6	3	15 x 3	22,5	28,0	4 x a	7 x a	0,57	–	0,28	–
–	136	6,5	6	3	15 x 2	30,0	28,0	3 x a	8 x a	0,58	–	0,28	–
–	166	6,5	6	3	15 x 4	30,0	28,0	5 x a	10 x a	0,74	–	0,36	–
–	186	6,5	6	3	15 x 4	35,0	28,0	5 x a	11 x a	0,80	–	0,38	–
–	221	6,5	6	3	15 x 5	40,0	28,0	8 x a	14 x a	1,00	–	0,47	–
–	266	6,5	6	3	15 x 6	47,5	28,0	9 x a	17 x a	1,12	–	0,52	–
<b>35</b>	<b>107</b>	<b>7,5</b>	<b>8</b>	<b>6</b>	<b>25 x 1</b>	<b>25,0</b>	<b>37,5</b>	<b>2 x a</b>	<b>3 x a</b>	<b>0,77</b>	<b>1,05</b>	<b>0,43</b>	<b>0,52</b>
35	142	7,5	8	6	25 x 2	27,5	37,5	3 x a	4 x a	0,98	1,33	0,54	0,66
35	167	7,5	8	6	25 x 3	27,5	37,5	4 x a	5 x a	1,17	1,60	0,65	0,79
35	192	7,5	8	6	25 x 4	27,5	37,5	5 x a	6 x a	1,37	1,86	0,75	0,92
35	217	7,5	8	6	25 x 3	40,0	37,5	5 x a	7 x a	1,38	1,88	0,73	0,90
35	242	7,5	8	6	25 x 4	40,0	37,5	6 x a	8 x a	1,58	2,15	0,83	1,03
35	267	7,5	8	6	25 x 3	52,5	37,5	6 x a	9 x a	1,59	2,16	0,81	1,01
35	267	7,5	8	6	25 x 5	40,0	37,5	7 x a	9 x a	1,77	2,41	0,94	1,17
35	292	7,5	8	6	25 x 4	52,5	37,5	7 x a	10 x a	1,79	2,43	0,92	1,14
<b>35</b>	<b>107</b>	<b>7,5</b>	<b>8</b>	<b>6</b>	<b>25 x 1</b>	<b>25,0</b>	<b>43,0</b>	<b>1 x a</b>	<b>2 x a</b>	<b>1,14</b>	<b>1,48</b>	<b>0,72</b>	<b>0,83</b>
35	142	7,5	8	6	25 x 2	27,5	43,0	2 x a	3 x a	1,60	2,04	1,06	1,20
35	167	7,5	8	6	25 x 3	27,5	43,0	3 x a	4 x a	2,05	2,57	1,39	1,57
35	192	7,5	8	6	25 x 4	27,5	43,0	4 x a	5 x a	2,50	3,11	1,73	1,94
35	217	7,5	8	6	25 x 3	40,0	43,0	4 x a	6 x a	2,31	2,92	1,50	1,71
35	242	7,5	8	6	25 x 4	40,0	43,0	5 x a	6 x a	2,75	3,46	1,83	2,08
35	267	7,5	8	6	25 x 3	52,5	43,0	5 x a	7 x a	2,56	3,27	1,60	1,85
35	267	7,5	8	6	25 x 5	40,0	43,0	5 x a	7 x a	3,20	4,00	2,17	2,45
35	292	7,5	8	6	25 x 4	52,5	43,0	5 x a	8 x a	3,01	3,81	1,93	2,22
35	317	7,5	8	6	25 x 7	40,0	43,0	7 x a	9 x a	4,10	5,08	2,84	3,19
35	367	7,5	8	6	25 x 5	65,0	43,0	7 x a	10 x a	3,72	4,69	2,37	2,73
<b>44</b>	<b>142</b>	<b>10,5</b>	<b>8</b>	<b>6</b>	<b>25 x 2</b>	<b>27,5</b>	<b>52,0</b>	–	<b>2 x a</b>	<b>1,84</b>	<b>2,53</b>	<b>0,93</b>	<b>1,17</b>
44	167	10,5	8	6	25 x 3	27,5	52,0	1 x a	2 x a	2,20	3,03	1,09	1,39
44	192	10,5	8	6	25 x 4	27,5	52,0	1 x a	2 x a	2,56	3,54	1,26	1,62
44	217	10,5	8	6	25 x 3	40,0	52,0	1 x a	3 x a	2,64	3,62	1,27	1,63
44	242	10,5	8	6	25 x 4	40,0	52,0	2 x a	3 x a	3,00	4,13	1,44	1,86
44	267	10,5	8	6	25 x 3	52,5	52,0	2 x a	4 x a	3,09	4,21	1,45	1,87
44	267	10,5	8	6	25 x 5	40,0	52,0	2 x a	4 x a	3,36	4,63	1,61	2,09
44	292	10,5	8	6	25 x 4	52,5	52,0	2 x a	4 x a	3,45	4,72	1,62	2,10
44	317	10,5	8	6	25 x 7	40,0	52,0	3 x a	4 x a	4,08	5,63	1,95	2,55
44	367	10,5	8	6	25 x 5	65,0	52,0	3 x a	5 x a	4,25	5,81	1,96	2,56
44	367	10,5	8	6	25 x 9	40,0	52,0	4 x a	5 x a	4,79	6,64	2,28	3,00
44	417	10,5	8	6	25 x 7	65,0	52,0	4 x a	6 x a	4,97	6,81	2,30	3,02
44	442	10,5	8	6	25 x 6	77,5	52,0	4 x a	6 x a	5,06	6,90	2,31	3,03
<b>50</b>	<b>172</b>	<b>12,0</b>	<b>11</b>	<b>6</b>	<b>50 x 1</b>	<b>42,5</b>	<b>74,0</b>	<b>1 x a</b>	<b>1 x a</b>	<b>4,09</b>	<b>4,96</b>	<b>2,28</b>	<b>2,57</b>
50	222	12,0	11	6	50 x 1	55,0	74,0	1 x a	2 x a	4,77	5,78	2,55	2,90
50	272	12,0	11	6	50 x 2	55,0	74,0	1 x a	3 x a	6,03	7,34	3,21	3,67
50	322	12,0	11	6	50 x 3	55,0	74,0	2 x a	3 x a	7,30	8,90	3,87	4,45
50	372	12,0	11	6	50 x 2	80,0	74,0	2 x a	4 x a	7,39	8,98	3,75	4,33
50	372	12,0	11	6	50 x 4	55,0	74,0	3 x a	4 x a	8,57	10,45	4,53	5,22
50	422	12,0	11	6	50 x 3	80,0	74,0	3 x a	4 x a	8,65	10,54	4,41	5,10
50	472	12,0	11	6	50 x 4	80,0	74,0	3 x a	5 x a	9,92	12,10	5,07	5,80
50	522	12,0	11	6	50 x 3	105,0	74,0	3 x a	5 x a	10,01	12,18	4,95	5,75
50	522	12,0	11	6	50 x 5	80,0	74,0	4 x a	5 x a	11,19	13,65	5,73	6,65
<b>66</b>	<b>276</b>	<b>14,0</b>	<b>15</b>	<b>8</b>	<b>100 x 1</b>	<b>55,0</b>	<b>108,0</b>	<b>1 x a</b>	<b>1 x a</b>	<b>10,16</b>	<b>13,56</b>	<b>5,95</b>	<b>7,13</b>
66	326	14,0	15	8	100 x 1	80,0	108,0	1 x a	2 x a	14,84	18,97	8,57	10,04
66	426	14,0	15	8	100 x 1	105,0	108,0	2 x a	3 x a	17,25	22,12	9,53	11,29
66	526	14,0	15	8	100 x 1	130,0	108,0	2 x a	3 x a	19,65	25,26	10,48	12,54
66	526	14,0	15	8	100 x 2	105,0	108,0	3 x a	3 x a	22,22	28,56	12,26	14,61
66	626	14,0	15	8	100 x 2	130,0	108,0	3 x a	4 x a	24,62	31,71	13,22	15,86
66	626	14,0	15	8	100 x 3	105,0	108,0	3 x a	4 x a	27,19	35,01	15,00	17,93
66	726	14,0	15	8	100 x 2	155,0	108,0	3 x a	5 x a	27,03	34,85	14,17	17,11
66	826	14,0	15	8	100 x 3	155,0	108,0	4 x a	6 x a	32,00	41,30	16,91	20,43
<b>75</b>	<b>326</b>	<b>19,5</b>	<b>15</b>	<b>8</b>	<b>100 x 1</b>	<b>80,0</b>	<b>150,0</b>	<b>1 x a</b>	<b>1 x a</b>	<b>23,87</b>	<b>29,20</b>	<b>12,36</b>	<b>14,25</b>
75	426	19,5	15	8	100 x 1	105,0	150,0	1 x a	2 x a	28,16	34,45	14,06	16,33
75	526	19,5	15	8	100 x 1	130,0	150,0	2 x a	2 x a	32,46	39,70	15,77	18,42
75	526	19,5	15	8	100 x 2	105,0	150,0	2 x a	2 x a	36,31	44,50	18,06	21,09
75	626	19,5	15	8	100 x 2	130,0	150,0	2 x a	3 x a	40,60	49,75	19,77	23,17
75	626	19,5	15	8	100 x 3	105,0	150,0	2 x a	3 x a	44,45	54,55	22,05	25,84
75	726	19,5	15	8	100 x 2	155,0	150,0	2 x a	4 x a	44,90	55,00	21,47	25,26
75	826	19,5	15	8	100 x 3	155,0	150,0	3 x a	4 x a	53,05	65,05	25,47	30,01

\*Bohrbild – Ba (Außenteil) und Bi (Innenteil) – siehe Seite 36  
Drilling plan – Ba (exterior part) and Bi (interior part) – see page 36



Miniatur-Rollen-Schlitten sind offen oder mit Endplatten lieferbar. Das Außenteil ist aus Aluminium gefertigt, das Innenteil besteht aus gehärtetem Stahl. Mit Standardbohrbild.

The miniature roller slides can be delivered either as open type or with end plates. The exterior part is made of aluminium, the interior part consists of hardened steel. With standard drilling pattern.

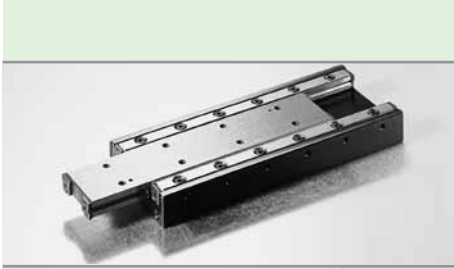

**MOAN**

offene Ausführung

open type



**MEAN**

mit Endplatten

with end plates

**Miniatur-Rollen-Schlitten, Grundmaße für alle Baureihen**  
*Miniature roller slides, basic sizes for all lines*

Größe Size	B	A	D	E	F	G	H	J	K	M	N	d
030	12	11,7	5,3	0,3	6	6,3	10,0	23,0	8,7	M3	2	
040	15	14,7	6,3	0,3	8	8,3	14,4	33,8	10,7	M3	3	
060	17	16,7	8,3	0,3	8	8,3	30,6	50,0	12,7	M3	3	

**4.1 Bohrbilder MOAN/MEAN**  
*Drilling plans MOAN/MEAN*

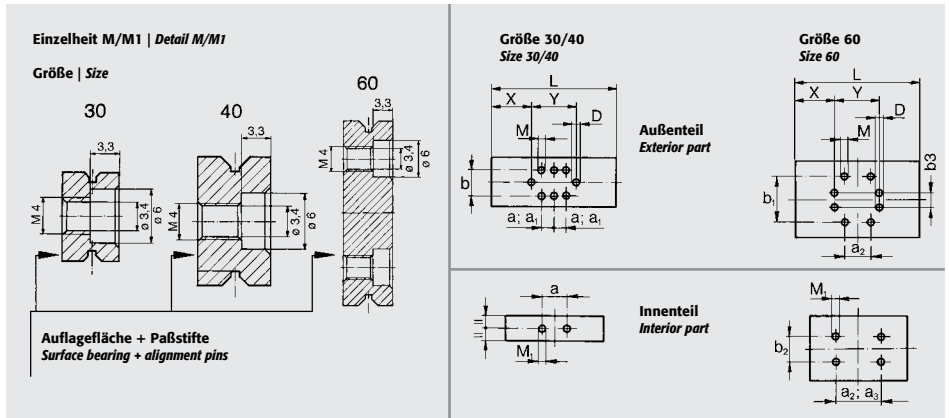

Größe Size	Länge length	Stand. Bohrbild Standard drilling patterns															
		Außenteil Outside part					Innenteil Inside part					MOAN MEAN					
B	L	X	Y	b3	D	MOAN	MEAN	a	a1	a2	a3	b	b1	b2	M	M1	
030	035	17,5	-	-	5,7	2 x a	1 x a	-	10	20	-	-	10	-	-	M3 x 5	M4 x 3,3
030	050	25	-	-	5,7	2 x a	1 x a	-	10	20	-	-	10	-	-	M3 x 5	M4 x 3,3
030	065	25	15	-	5,7	2 x a1	3 x a	1 x a	10	20	-	-	10	-	-	M3 x 5	M4 x 3,3
030	080	25	30	-	5,7	2 x a1	5 x a	1 x a	10	20	-	-	10	-	-	M3 x 5	M4 x 3,3
030	095	32,5	30	-	5,7	4 x a1	7 x a	-	10	20	-	-	10	-	-	M3 x 5	M4 x 3,3
030	110	40	30	-	5,7	4 x a1	7 x a	3 x a	10	20	-	-	10	-	-	M3 x 5	M4 x 3,3
030	125	47,5	30	-	5,7	4 x a1	9 x a	5 x a	10	20	-	-	10	-	-	M3 x 5	M4 x 3,3
040	055	27,5	-	-	5,7	2 x a1	1 x a	-	20	20	-	-	20	-	-	M3 x 6	M4 x 5
040	080	40	-	-	5,7	2 x a1	1 x a	1 x a	20	20	-	-	20	-	-	M3 x 6	M4 x 5
040	105	42,5	20	-	5,7	4 x a1	3 x a	1 x a	20	20	-	-	20	-	-	M3 x 6	M4 x 5
040	130	40	50	-	5,7	4 x a1	5 x a	1 x a	20	20	-	-	20	-	-	M3 x 6	M4 x 5
040	155	52,5	50	-	5,7	6 x a1	5 x a	3 x a	20	20	-	-	20	-	-	M3 x 6	M4 x 5
060	055	27,5	-	18	5,7	1 x a2	1 x a2	-	-	-	18	18	-	36	18	M3 x 6	M4 x 5
060	080	25	30	18	5,7	3 x a2	1 x a3	-	-	-	18	36	-	36	18	M3 x 6	M4 x 5
060	105	52,5	-	18	5,7	5 x a2	1 x a3	1 x a3	-	-	18	36	-	36	18	M3 x 6	M4 x 5
060	130	65	-	18	5,7	5 x a2	1 x a3	1 x a3	-	-	18	36	-	36	18	M3 x 6	M4 x 5
060	155	52,5	50	18	5,7	7 x a2	3 x a3	1 x a3	-	-	18	36	-	36	18	M3 x 6	M4 x 5
060	180	75	30	18	5,7	9 x a2	3 x a3	1 x a3	-	-	18	36	-	36	18	M3 x 6	M4 x 5
060	205	87,5	30	18	5,7	9 x a2	3 x a3	1 x a3	-	-	18	36	-	36	18	M3 x 6	M4 x 5

**4.2 MOAN**  
offene Ausführung

*open type*

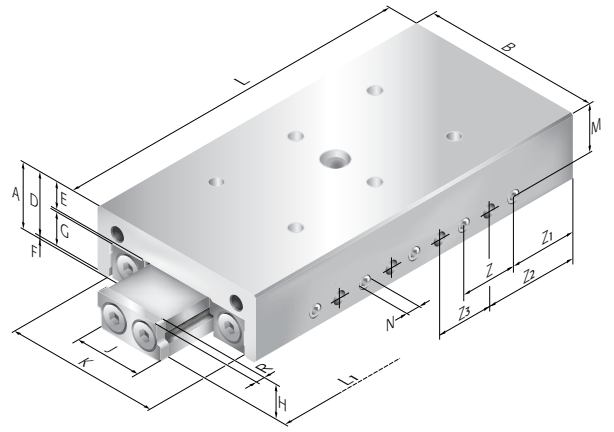

**Miniatur-Rollen-Schlitten, Baureihe MOAN**  
*Miniature roller slides, MOAN line*

Größe Size	Länge Length	Normaler Hub Standard stroke	Langer Hub Long stroke		Höhe Height						Gewicht Weight
B	L	C	C	L1	A	Z	Z1	Z2	Z3	R	kg
030	035	012	020	030	12	15 x 1	10	–	–	2,5	0,06
030	050	018	034	045	12	15 x 2	10	–	–	2,5	0,08
030	065	024	048	060	12	15 x 3	10	17,5	15 x 2	2,5	0,10
030	080	030	064	075	12	15 x 4	10	–	–	2,5	0,13
030	095	040	084	090	12	15 x 5	10	–	–	2,5	0,15
030	110	050	098	105	12	15 x 6	10	32,5	15 x 3	2,5	0,18
030	125	060	120	120	12	15 x 7	10	32,5	15 x 4	2,5	0,20
040	055	020	040	050	15	25 x 1	15	–	–	2,5	0,14
040	080	030	060	075	15	25 x 2	15	27,5	25 x 1	2,5	0,20
040	105	040	080	100	15	25 x 3	15	27,5	25 x 2	2,5	0,27
040	130	050	100	125	15	25 x 4	15	–	–	2,5	0,34
040	155	060	120	150	15	25 x 5	15	–	–	2,5	0,41
060	055	020	030	050	17	25 x 1	15	–	–	2,5	0,66
060	080	030	060	075	17	25 x 2	15	–	–	2,5	0,80
060	105	040	080	100	17	25 x 3	15	27,5	25 x 2	2,5	0,93
060	130	050	100	125	17	25 x 4	15	–	–	2,5	1,07
060	155	060	120	150	17	25 x 5	15	–	–	2,5	1,20
060	180	080	140	175	17	25 x 6	15	52,5	25 x 3	2,5	1,33
060	205	100	160	200	17	25 x 7	15	52,5	25 x 4	2,5	1,47

**4.3 MEAN**  
mit Endplatten

*with end plates*

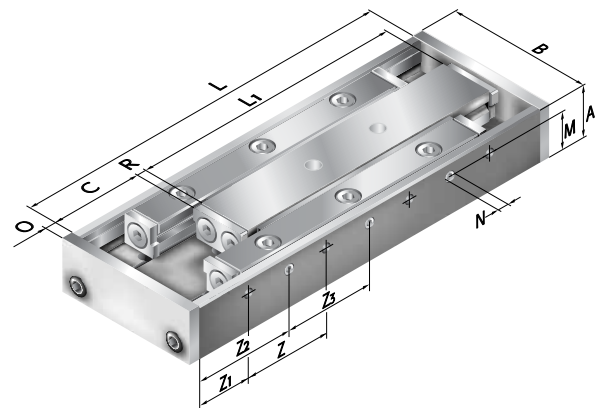

**Miniatur-Rollen-Schlitten, Baureihe MEAN**  
*Miniature roller slides, MEAN line*

Größe Size	Länge Length	Hub Stroke		Höhe Height							Gewicht Weight
B	L	C	L1	A	O	Z	Z1	Z2	Z3	R	kg
030	065	015	045	12	3	15 x 3	10	17,5	15 x 2	2,5	0,07
030	080	030	045	12	3	15 x 4	10	–	–	2,5	0,08
030	110	045	060	12	3	15 x 6	10	32,5	15 x 3	2,5	0,10
030	125	045	075	12	3	15 x 7	10	32,5	15 x 4	2,5	0,13
040	080	025	050	15	3	25 x 2	15	27,5	25 x 1	2,5	0,13
040	105	025	075	15	3	25 x 3	15	27,5	25 x 2	2,5	0,18
040	130	050	075	15	3	25 x 4	15	–	–	2,5	0,21
040	155	050	100	15	3	25 x 5	15	–	–	2,5	0,25
060	105	025	075	17	3	25 x 3	15	27,5	25 x 2	2,5	0,33
060	130	050	075	17	3	25 x 4	15	–	–	2,5	0,37
060	155	050	100	17	3	25 x 5	15	–	–	2,5	0,46
060	180	050	125	17	3	25 x 6	15	52,5	25 x 3	2,5	0,55
060	180	075	100	17	3	25 x 6	15	52,5	25 x 3	2,5	0,50
060	205	075	125	17	3	25 x 7	15	52,5	25 x 4	2,5	0,59

Schwalbenschwanz-Schlitten und Rollen-Schlitten können zu Kreuztischen montiert werden. Für die Montage von Kreuzschlitten benötigen wir folgende Informationen:  
 Typ unterer Schlitten (z.B. RMGN 100 0310 0100),  
 Typ oberer Schlitten (z.B. RMGN 100 0135 0025),  
 Montageart (rechts oder links/ umgekehrt oder normal).  
 Bei außermittiger Montage benötigen wir zusätzlich die Maße A und B.

*The dovetail slides and the roller slides can be assembled so as to create cross slides. For the assembly of cross tables using these components we are in need of the following information:  
 type of lower slide (e.g. RMGN 100 0310 0100),  
 type of upper slide (e.g. RMGN 100 0135 0025),  
 type of assembly required (to the right or to the left / reversed or normal).  
 In case of an assembly off-centre, we'd also need sizes A and B.*

**Rechts-Montage**  
*Right-hand mounting*

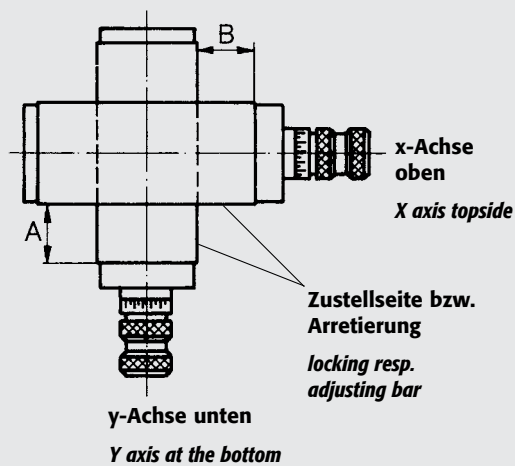

**Links-Montage**  
*Left-hand mounting*

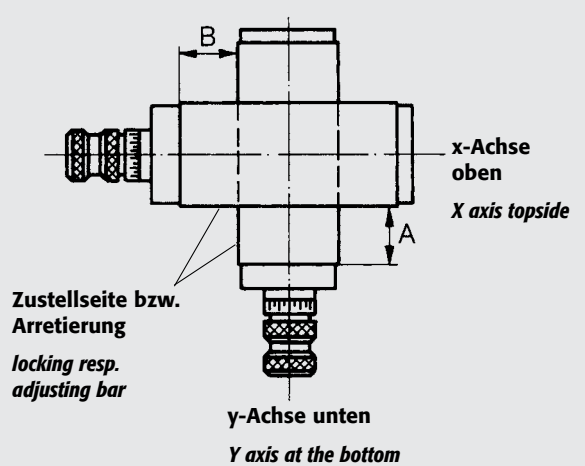



**Toleranzen und Ablaufgenauigkeiten  
für GG 25, bei Al + 50 %**

*Tolerances and travel accuracy  
if made of grey cast iron (GG 25) and of alu-  
minium + 50 %*

Ablauftoleranzen,  
gemessen über den  
gesamten Hub

*Travel tolerances measured  
over the whole stroke*

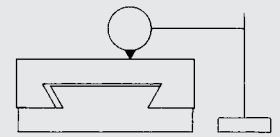
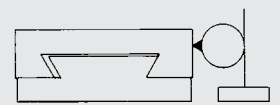
**a**

**b**

Parallelität in  
Mittelstellung

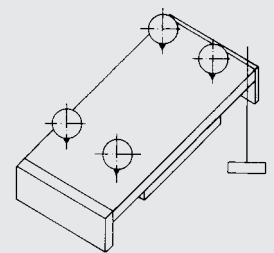
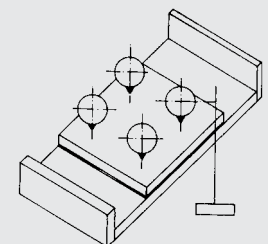
*Parallelism in  
centre position*

**c**

**d**

Auf Wunsch liefern wir auch mehrere Schlitten  
mit der gleichen Bauhöhe – Höhentoleranz  
 $\pm 0,01$  mm.

*If desired, we can also furnish several slides  
of the same overall height – height tolerance:  
 $\pm 0.01$  mm.*

Alle Toleranzen basieren auf Befestigung mit  
unseren Bohrbildern, sowie einer An- und  
Auflagefläche mit einer Ebenheit von  $0,01/200$  mm.

*All tolerances indicated are operative only if mounted follo-  
wing our drilling plans supplied  
with the devices and only if a standard bearing surface of  
 $0.01 / 200$  mm is applied.*

**Rollengelagerte Schlitten  
Slides running on roller bearings**

Schlittenlänge Length of slide	Abweichungen in $\mu\text{m}$ Deviations in $\mu\text{m}$			
	a	b	c	d
- 100 mm	4	4	15	15
- 200 mm	4	6	20	20
- 400 mm	5	8	30	20
- 800 mm	7	10	40	20
-1000 mm	10	12	50	25

**Schwalbenschwanz-Schlitten  
Dovetail slides**

Schlittenlänge Length of slide	Abweichungen in $\mu\text{m}$ Deviations in $\mu\text{m}$			
	a	b	c	d
- 100 mm	8	10	20	20
- 200 mm	12	15	25	25
- 400 mm	18	22	35	25
- 800 mm	18	30	50	30
-1200 mm	30	40	65	40

Engere Toleranzen  
auf Anfrage

*More exacting tolerances on  
demand*

Für die Baumaße der Schlitten gelten die  
Grundtoleranzen IT 11 DIN ISO 286-1.

*As for the structural dimensions of  
slides, the basic tolerances specified in  
IT 11 DIN ISO 286-1 have been complied with.*

## 7.1 Kreuzrollen- Führungsschienen Typ R

### Cross roller guide rails Type R



Unsere Kreuzrollen-Führungsschienen sind garantiert untereinander austauschbare Normelemente. Sie finden Anwendung im Maschinen- und Vorrichtungsbau, in der Meß- und Kontrolltechnik.

Ihre Vorteile sind hohe Belastbarkeit, äußerste Leichtgängigkeit, kleiner Platzbedarf und lange Lebensdauer.

Unsere Führungen gestatten den Bau absolut spielfreier, äußerst steifer und genauer linearer Längsführungen.

#### Einbauvorschrift:

Bei Einbau der Führungsschienen ist darauf zu achten, daß die Auflageflächen parallel und winklig bearbeitet sind. Die Toleranzen der Auflage- bzw. Montageflächen sollen den Fertigungstoleranzen der Führungsschienen (Normalqualität) entsprechen.

Die Vorspannung richtet sich nach den jeweiligen Einbauverhältnissen bzw. Starrheit der Schlitten-Konstruktion. Wir empfehlen eine Vorspannung zwischen 5 und 20% der max. Belastung. Die Tragfähigkeit der kompletten Schlittenführung wird auf jeden Fall um die eingestellte Vorspannung gemindert.

Passende Rollenkäfige finden Sie auf Seite 29.

*Our cross roller guide rails are freely interchangeable standard elements. They are on duty in different fields, such as in the machine, jigs and fixtures construction as well as in the measuring and control engineering business.*

*Able to carry high loads and running extremely smooth, they require little space and are of a long serviceable life, the chief advantages that characterise these guides. Our guide rails allow the assembly of extremely rigid and precise linear guides without any play.*

#### Mounting instructions:

*When mounting the guide rails make sure the bearing surfaces have been machined in a parallel manner and are to the angle. The tolerances of the bearing and mounting surfaces shall conform to the process tolerances of the guide rails (standard quality).*

*The prestress applied depends on the respective mounting conditions, on the rigidity of the assembled slide structure respectively. We recommend to apply a prestress equivalent to a value between 5 and 20 % of the maximum admissible load. However, the load carrying ability of the overall guide rail structure thus realized will, at any case, be reduced by the prestress applied.*

*For appropriate roller cages please refer to page 29.*

µm Fertigungstoleranzen | Process tolerances

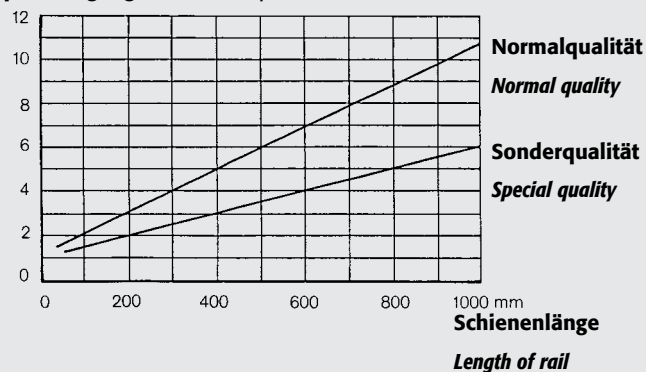

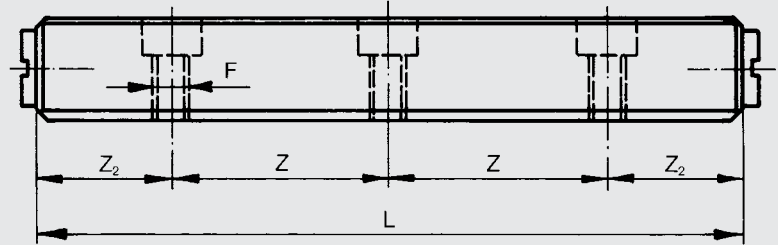
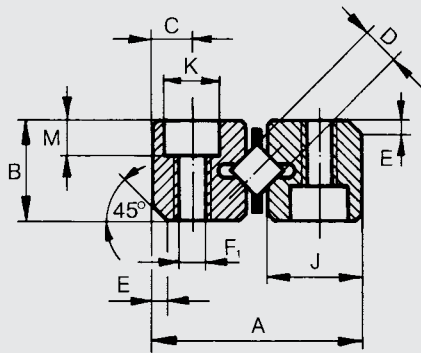

Bestell-Nr. Order no.	B	L	C	A	D	Z	Z2	J	E	F	F1	K	M	Tragkraft pro Rolle Carrying force per roller N	Gewicht der Schiene Weight of the rail kg
D x L															
R2 030	6	30	2,5	12	2	1 x 15	7,5	5,5	1,0	M3	Ø2,55	4,4	2,2	60	0,008
R2 045	6	45	2,5	12	2	2 x 15	7,5	5,5	1,0	M3	Ø2,55	4,4	2,2	60	0,011
R2 060	6	60	2,5	12	2	3 x 15	7,5	5,5	1,0	M3	Ø2,55	4,4	2,2	60	0,014
R2 075	6	75	2,5	12	2	4 x 15	7,5	5,5	1,0	M3	Ø2,55	4,4	2,2	60	0,017
R2 090	6	90	2,5	12	2	5 x 15	7,5	5,5	1,0	M3	Ø2,55	4,4	2,2	60	0,020
R2 105	6	105	2,5	12	2	6 x 15	7,5	5,5	1,0	M3	Ø2,55	4,4	2,2	60	0,023
R2 120	6	120	2,5	12	2	7 x 15	7,5	5,5	1,0	M3	Ø2,55	4,4	2,2	60	0,026
R3 050	8	50	3,5	18	3	1 x 25	12,5	8,3	1,0	M4	Ø3,4	6,0	3,2	100	0,023
R3 075	8	75	3,5	18	3	2 x 25	12,5	8,3	1,0	M4	Ø3,4	6,0	3,2	100	0,034
R3 100	8	100	3,5	18	3	3 x 25	12,5	8,3	1,0	M4	Ø3,4	6,0	3,2	100	0,045
R3 125	8	125	3,5	18	3	4 x 25	12,5	8,3	1,0	M4	Ø3,4	6,0	3,2	100	0,056
R3 150	8	150	3,5	18	3	5 x 25	12,5	8,3	1,0	M4	Ø3,4	6,0	3,2	100	0,067
R3 175	8	175	3,5	18	3	6 x 25	12,5	8,3	1,0	M4	Ø3,4	6,0	3,2	100	0,078
R3 200	8	200	3,5	18	3	7 x 25	12,5	8,3	1,0	M4	Ø3,4	6,0	3,2	100	0,089
R3 225	8	225	3,5	18	3	8 x 25	12,5	8,3	1,0	M4	Ø3,4	6,0	3,2	100	0,100
R3 250	8	250	3,5	18	3	9 x 25	12,5	8,3	1,0	M4	Ø3,4	6,0	3,2	100	0,111
R3 275	8	275	3,5	18	3	10 x 25	12,5	8,3	1,0	M4	Ø3,4	6,0	3,2	100	0,122
R3 300	8	300	3,5	18	3	11 x 25	12,5	8,3	1,0	M4	Ø3,4	6,0	3,2	100	0,133
R6 100	15	100	6,0	31	6	1 x 50	25,0	13,9	1,8	M6	Ø5,4	10,0	5,2	400	0,145
R6 150	15	150	6,0	31	6	2 x 50	25,0	13,9	1,8	M6	Ø5,4	10,0	5,2	400	0,220
R6 200	15	200	6,0	31	6	3 x 50	25,0	13,9	1,8	M6	Ø5,4	10,0	5,2	400	0,295
R6 250	15	250	6,0	31	6	4 x 50	25,0	13,9	1,8	M6	Ø5,4	10,0	5,2	400	0,370
R6 300	15	300	6,0	31	6	5 x 50	25,0	13,9	1,8	M6	Ø5,4	10,0	5,2	400	0,445
R6 350	15	350	6,0	31	6	6 x 50	25,0	13,9	1,8	M6	Ø5,4	10,0	5,2	400	0,520
R6 400	15	400	6,0	31	6	7 x 50	25,0	13,9	1,8	M6	Ø5,4	10,0	5,2	400	0,595
R6 450	15	450	6,0	31	6	8 x 50	25,0	13,9	1,8	M6	Ø5,4	10,0	5,2	400	0,670
R6 500	15	500	6,0	31	6	9 x 50	25,0	13,9	1,8	M6	Ø5,4	10,0	5,2	400	0,745
R6 600	15	600	6,0	31	6	11 x 50	25,0	13,9	1,8	M6	Ø5,4	10,0	5,2	400	0,815
R6 700	15	700	6,0	31	6	13 x 50	25,0	13,9	1,8	M6	Ø5,4	10,0	5,2	400	1,010
R6 800	15	800	6,0	31	6	15 x 50	25,0	13,9	1,8	M6	Ø5,4	10,0	5,2	400	1,160
R9 150	22	150	9,0	44	9	1 x 100	25,0	19,7	2,5	M8	Ø6,8	11,5	6,2	1000	0,473
R9 200	22	200	9,0	44	9	1 x 100	50,0	19,7	2,5	M8	Ø6,8	11,5	6,2	1000	0,630
R9 300	22	300	9,0	44	9	2 x 100	50,0	19,7	2,5	M8	Ø6,8	11,5	6,2	1000	0,946
R9 400	22	400	9,0	44	9	3 x 100	50,0	19,7	2,5	M8	Ø6,8	11,5	6,2	1000	1,260
R9 500	22	500	9,0	44	9	4 x 100	50,0	19,7	2,5	M8	Ø6,8	11,5	6,2	1000	1,575
R9 600	22	600	9,0	44	9	5 x 100	50,0	19,7	2,5	M8	Ø6,8	11,5	6,2	1000	1,892
R9 700	22	700	9,0	44	9	6 x 100	50,0	19,7	2,5	M8	Ø6,8	11,5	6,2	1000	2,205
R9 800	22	800	9,0	44	9	7 x 100	50,0	19,7	2,5	M8	Ø6,8	11,5	6,2	1000	2,520
R9 900	22	900	9,0	44	9	8 x 100	50,0	19,7	2,5	M8	Ø6,8	11,5	6,2	1000	2,838
R9 1000	22	1000	9,0	44	9	9 x 100	50,0	19,7	2,5	M8	Ø6,8	11,5	6,2	1000	3,150

**7.1.1  
Schienenbefestigungs- und  
Zustellschrauben bei  
Rollen-Schlitten**

*Fixing screw for rails and adjusting  
screws for roller slides*

Bohrungsabstände in Längsrichtung  
auf den Seiten 15, 17, 19  
– siehe Werte Z und Z1

*Drill hole distances in lengthwise direction  
indicated on pages 15, 17, 19 – see values  
Z and Z1*

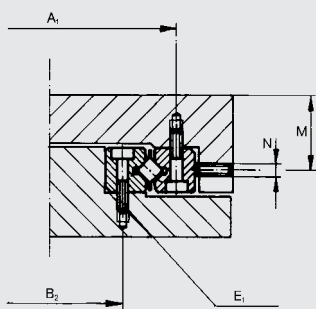

**Ausführung "C"**  
**Execution "C"**

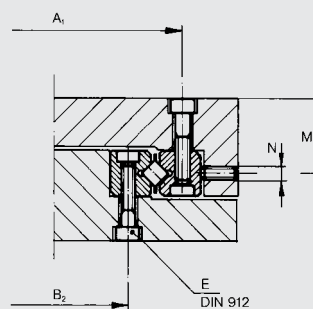

**Ausführung "D"**  
**Execution "D"**

Größe Size	A1	B2	E1	E DIN 912	M	N
<b>040</b>	28,0	14,0	M2	M3	10,0	M3
<b>050</b>	37,5	15,5	M3	M4	11,0	M3
<b>060</b>	43,0	21,0	M3	M4	11,0	M4
<b>075</b>	52,0	30,0	M3	M4	13,0	M5
<b>100</b>	74,0	36,0	M5	M6	19,5	M6
<b>K 150</b>	114,0	76,0	M5	M6	21,5	M6
<b>R 150</b>	108,0	56,0	M6	M8	24,5	M8
<b>200</b>	150,0	98,0	M6	M8	29,0	M8

Standardausführungen

Schlitten-Typ:

- R 40 – Ausführung D
- RA-Außenteil – Ausführung D
- RA-Innenteil – Ausführung C
- R ab Gr. 50 – Ausführung C

Standard models

Slide type:

- RA 40 – Execution D
- RA, exterior part – Execution D
- RA, interior part – Execution C
- R from size 50 on – Execution C

### 7.1.2 Endschrauben und Endstücke für Rollenkäfige

*Tail screws and end pieces for  
roller cages*

#### DD für Rollenkäfig Typ RK und DD for roller cages type RK and DD

DD: für vertikalen Einbau  
und schnelle Bewegung

*DD: for vertical installation  
and for rapid motion*

RK: für vertikalen Einbau

*RK: for vertical mounting*

für Größe  
for size  
R 2

für Größe  
for size  
∕ H  
R 3 2 mm  
R 6 3 mm  
R 9 3 mm

DM  
für längere Hübe und  
größere Belastungen

*for longer strokes and for  
higher loads*

für Größe  
for size  
∕ H  
R 6 3 mm  
R 9 3 mm

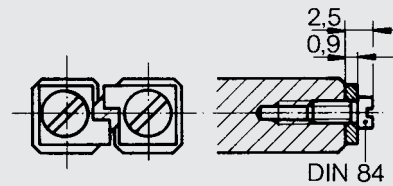

Endstück +  
Zyl. Schraube  
*End piece +  
fillister head screw*

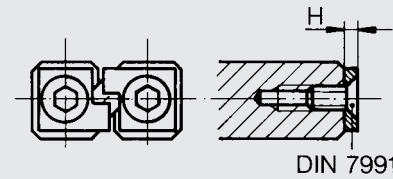

Endstück +  
Senkschraube  
*End piece +  
countersunk screw*

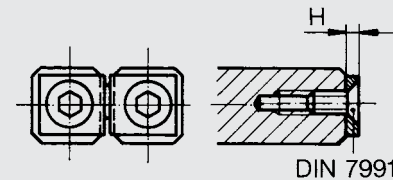

Endstück +  
Senkschraube  
*End piece +  
countersunk screw*

Bestelldaten: Typ x Größe  
Order code: type x size

### 7.2 Rollenkäfige Roller cages

DD  
Rollenkäfige für vertikalen  
Einbau und schnelle  
Bewegung

*Roller cages for vertical installation  
and for fast motion*

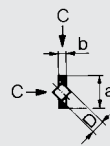

DM  
Rollenkäfige für lange  
Hübe und große  
Belastungen

*Roller cages for long strokes and  
strong loads*

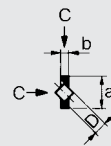

RK  
Rollenkäfig für  
vertikalen Einbau

*Roller cages for  
vertical installation*

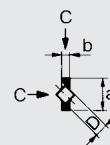

Sonderausführungen  
und andere Teilungen auf Anfrage.  
Berechnungsbeispiel:  
Anzahl der Rollen im Käfig:  
 $\frac{\text{Führungsschienenlänge} - \frac{1}{2} \text{ Hub}}{\text{Teilung } t}$

Special version and other divisions  
available upon request.  
Calculation example:  
Number of rollers in the cage:

$\frac{\text{Length of guide rail} - \frac{1}{2} \text{ stroke}}{\text{Division, size } t}$

Größe Size	D x	Typ DD, Typ DM Type DD, Type DM		t	Belastung C [N] Load C [N] Rolle Roller
		a	b		
R 2	2	4,5	0,5	4	60
R 3	3	7,5	1,0	5	100
R 6	6	15,0	2,4	RK 9, DD 12 DM 12, K 9	400
R 9	9	20,0	2,9	14	1000

Bestelldaten: Typ x D x Anzahl der Rollen (Kugeln)  
Order code: type x D x number of rollers (balls)





### 7.3 Gewinde- spindeln

#### Threaded spindles

Gewinde Thread D	Hub Stroke												Steigungsgenauigk. Pitch accuracy
		d1	d2	d3	d4	A	B	C	E	F	G	d5	
M5 x 0,5	20	M4	-	4f7	6,0	70	32,0	5,5	-	30,0	-	-	T6
M5 x 0,5	40	M4	-	4f7	6,0	90	52,0	5,5	-	30,0	-	-	T6
M5 x 0,5	50	M4	-	4f7	6,0	100	62,0	5,5	-	30,0	-	-	T6
M5 x 0,5	75	M4	-	4f7	6,0	125	87,0	5,5	-	30,0	-	-	T6
M6 x 1	25	5j5	-	-	7,5	92	46,5	-	-	38,5	-	-	T6
M6 x 1	50	5j5	-	-	7,5	117	71,5	-	-	38,5	-	-	T6
M6 x 1	75	5j5	-	-	7,5	142	96,5	-	-	38,5	-	-	T6
M6 x 1	100	5j5	-	-	7,5	167	121,5	-	-	38,5	-	-	T6
M10 x 1	25	5h7	M6 x 0,5	6g6	-	110	62,0	31,0	36,5	48,0	-	-	T6
M10 x 1	50	5h7	M6 x 0,5	6g6	-	135	87,0	31,0	36,5	48,0	-	-	T6
M10 x 1	75	5h7	M6 x 0,5	6g6	-	160	112,0	31,0	36,5	48,0	-	-	T6
M10 x 1	100	5h7	M6 x 0,5	6g6	-	185	137,0	31,0	36,5	48,0	-	-	T6
M10 x 1	150	5h7	M6 x 0,5	6g6	-	235	187,0	31,0	36,5	48,0	-	-	T6
M10 x 1	200	5h7	M6 x 0,5	6g6	-	285	237,0	31,0	36,5	48,0	-	-	T6
M10 x 1	250	5h7	M6 x 0,5	6g6	-	335	287,0	31,0	36,5	48,0	-	-	T6
TR16 x 2	50	10h7	M12 x 1	12j5	16,0	175	105,0	37,0	46,0	65,0	-	-	T8
TR16 x 2	100	10h7	M12 x 1	12j5	16,0	225	155,0	37,0	46,0	65,0	-	-	T8
TR16 x 2	150	10h7	M12 x 1	12j5	16,0	275	205,0	37,0	46,0	65,0	-	-	T8
TR16 x 2	200	10h7	M12 x 1	12j5	16,0	325	255,0	37,0	46,0	65,0	-	-	T8
TR16 x 2	250	10h7	M12 x 1	12j5	16,0	375	305,0	37,0	46,0	65,0	-	-	T8
TR16 x 2	300	10h7	M12 x 1	12j5	16,0	425	355,0	37,0	46,0	65,0	-	-	T8
TR16 x 2	400	10h7	M12 x 1	12j5	16,0	525	455,0	37,0	46,0	65,0	-	-	T8
TR16 x 2	500	10h7	M12 x 1	12j5	16,0	625	555,0	37,0	46,0	65,0	-	-	T8
TR16 x 2	600	10h7	M12 x 1	12j5	16,0	725	655,0	37,0	46,0	65,0	-	-	T8
TR20 x 4	100	12h7	M14 x 1	15j5	20,5	245	170,0	37,0	44,5	60,0	-	-	T4
TR20 x 4	150	12h7	M14 x 1	15j5	20,5	295	220,0	37,0	44,5	60,0	-	-	T4
TR20 x 4	200	12h7	M14 x 1	15j5	20,5	345	270,0	37,0	44,5	60,0	-	-	T4
TR20 x 4	300	12h7	M14 x 1	15j5	20,5	445	370,0	37,0	44,5	60,0	12	10h7	T4
TR20 x 4	400	12h7	M14 x 1	15j5	20,5	545	470,0	37,0	44,5	60,0	12	10h7	T4
TR20 x 4	500	12h7	M14 x 1	15j5	20,5	645	570,0	37,0	44,5	60,0	12	10h7	T4
TR20 x 4	600	12h7	M14 x 1	15j5	20,5	745	670,0	37,0	44,5	60,0	12	10h7	T4

#### Spindelansätze für Spindel | Spindle seats

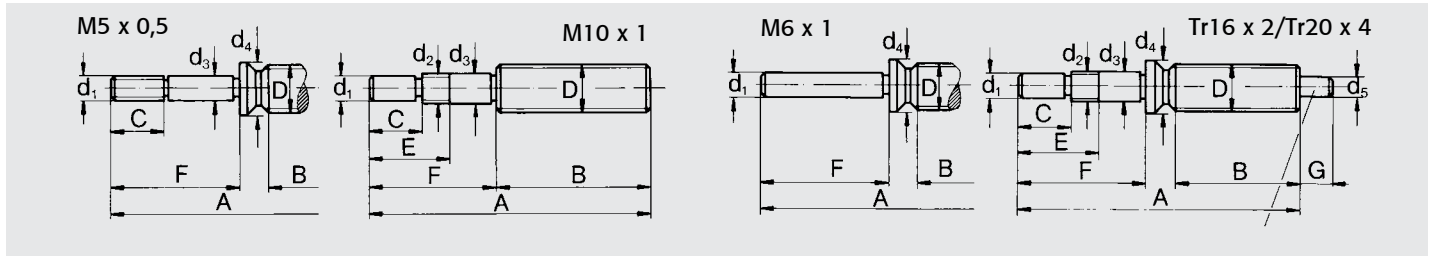

Bestelldaten: Gewinde D x Hub; M5 x 0,5 x 20  
Order code: thread D x stroke; M5 x 0.5 x 20

#### 7.3.1 Muttern

##### Precision nuts

Spindelmuttern aus Bronze, passend zu obenstehenden Spindeln

Precision spindle nuts suitable for the above listed spindles.

Gewinde Thread d5	D	D1	D2	B	d2	d6	H	H1	H2	H3	L	L1
M5 x 0,5	7h7	-	-	-	-	-	-	-	-	-	12	-
M6 x 1	9g7	-	-	-	M8 x 1	-	-	-	-	-	20	5
M10 x 1	14g7	-	-	-	M14 x 1	-	-	-	-	-	30	6
TR16 x 2	-	20	34	22,5	-	Km 4 DIN 74	11,5	28,5	6,0	12,75	40	9
TR20 x 4	-	26	49	30,3	-	Km 6 DIN 74	14,5	39,0	8,75	17,5	50	12

#### Größe M5 - M10 | Size M5 - M10

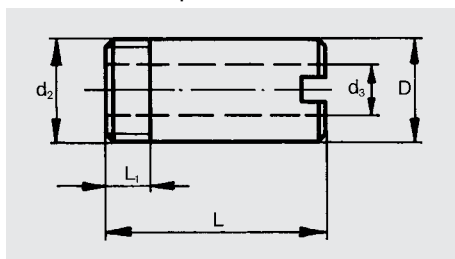

#### Größe TR16/TR20 | Size TR16/TR20

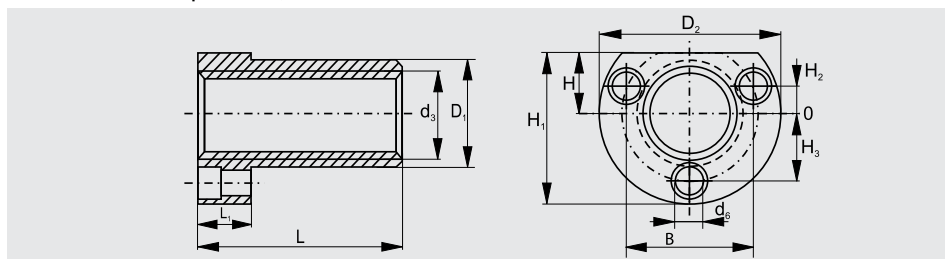

Bestelldaten: Gewinde D x Hub; M5 x 0,5 x 20  
Order code: thread D x stroke; M5 x 0.5 x 20

Die Betätigung erfolgt bei den Größen 050, 060 und 075 über Kreuzmutter, bei den Größen 100, 150, 200, 300 und 400 über verstellbare Klemmhebel.

Die Größen 150, 200, 300 und 400 sind auf Anfrage gegen Mehrpreis mit pneumatischer Klemmung lieferbar.

Bestelldaten: Seite 38

*With sizes 050, 060 and 075 activation is effected by means of cross nuts and with sizes 100, 150, 200, 300 and 400 by means of an adjustable clamping lever.*

*Upon demand and against surcharge, sizes 150, 200, 300 and 400 can be delivered with pneumatic clamping mechanism, too.*

*Order code: see page 38*

## 8.1 Arretierung

### Locking

#### 8.1.1 Arretierung Schwalbenschwanz-Schlitten

##### Dovetail slide locking



Die Arretierung erfolgt über verstellbare Klemmhebel direkt auf die Zustelleiste. Anzahl der Arretierungen siehe Seite 7 bis 10.

*The locking is made by adjustable clamping levers directly on the adjusting bar. The number of lockings see page 7 to 10.*

Breite Width	A	B	M	N
050	37	42	11,0	M5
075	38	42	14,5	M5
100	40	45	18,5	M6
150	45	62	22,5	M8
200	45	62	28,0	M8
300	55	74	38,0	M10
400	55	74	54,0	M10

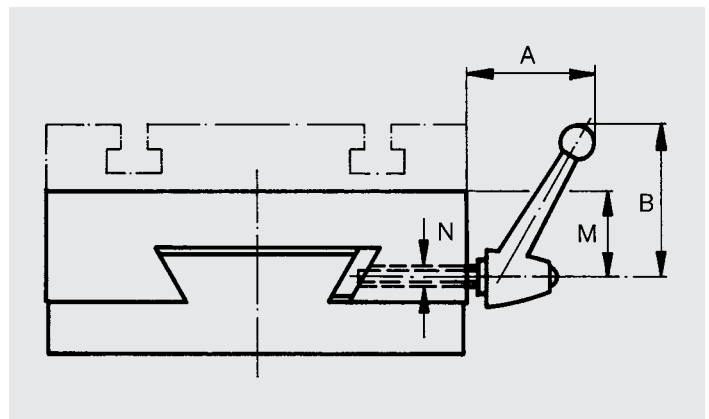

#### 8.1.2 Arretierung Rollen-Schlitten

##### Roller slide locking

Die Arretierung unserer Rollen-Schlitten gestattet ein Festklemmen des Schlittens in jeder Position. Eine Belastung der Führungen tritt dabei nicht auf.

*The locking of our roller bearing mounted slides allows to clamp the slide in every position. No load is exerted to the guides thereby.*

Realisierung der Arretierung bei Größe 040-060 über Kreuzgriff bei Größe 075 bis 200 über verstellbaren Klemmhebel bei Kreuztisch Größe 040 über Hutmutter SW7.

*size 040-060 with star handle  
size 075-200 with adjustable release handle  
compound tables size 40 with cap nut SW7.*

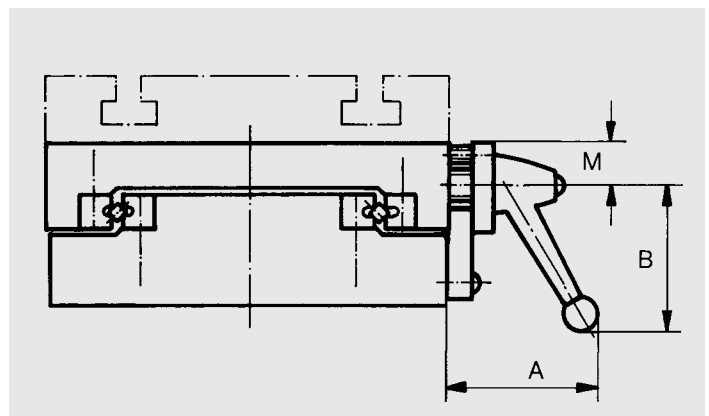

Breite Width	A	B	M
040	19	10	9,0
050	19	10	12,5
060	19	10	12,5
075	37	42	14,5
100	37	42	19,0
150	49	67	20,5
200	49	67	30,5

### 8.2 Abdichtung durch Abstreifer

*Sealing by means of scrapers*

Bei den Typen SE, SM RE, RM sind Abstreifer möglich. Der Schlitten muß dafür auf einer ebenen Fläche montiert sein. Gerne berät Sie auch unser Vertrieb.

*Scrapers can be realized with types SE, SM, RE and RM. For this purpose, the slide must be mounted on a plain surface. Our distribution service will be pleased to advise you.*

### 8.3 Faltenbalg-Abdeckung

*Bellows cover*

Bei den Typen SE, SS, SM, SK sowie RE, RS, RM und RK sind Faltenbalgabdeckungen möglich. Beim Faltenbalganbau ändert sich die Endplattenstärke von Maß R auf O1 (siehe Seiten 8, 10, 16 und 18). Die freie Montagefläche reduziert sich am Innenteil abhängig vom Hub. Bei Schlittengröße 50 ist keine Schmierung möglich.

*Bellows covers can be realized with types SE, SS, SM, SK as well as with RE, RS, RM and RK. In slides with bellows cover the endplate thickness changes from measure R to O1 (see pages 8, 10, 16 and 18). The free mounting area on the inside part is reduced dependent on the stroke. Lubricating on slide size 50 is not possible.*

#### Baugrößen 50 - 75 Sizes 50 - 75

Größe Size	C	A	FA	FB	FB1
50	11	25	41	95	89
60	11	25	41	105	99
75	15	32	51	127	120

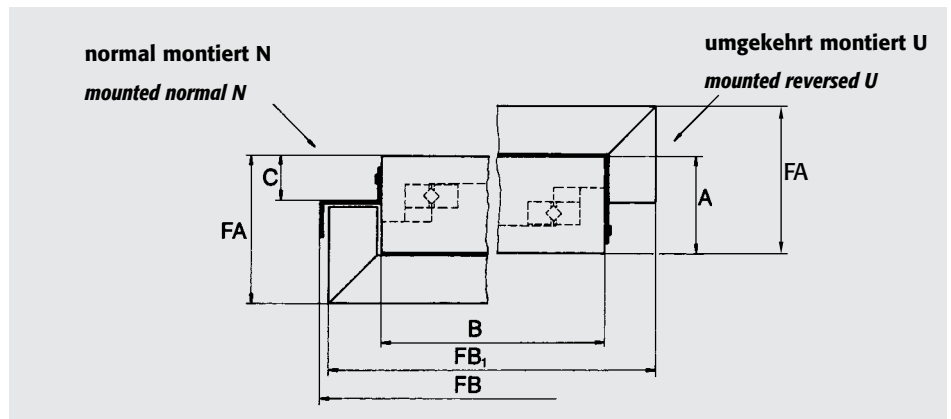

#### Ab Baugröße 100 From size 100 on

Größe Size	C	A	FA	D	FB	FB1	FB2	FB3
100	21	40	62	5	160	124	153	124
150	21	50	78	5	224	194	217	174
200	31	60	88	15	274	244	267	224
300	46	75	103	30	374	344	367	324
400	71	100	128	55	474	444	467	424

Bei Faltenbälgen mit Stahllamellen verändert sich abhängig vom Hub die Bauhöhe.

*With bellows covers equipped with steel lamellas the overall height of the structure will change depending on the stroke.*

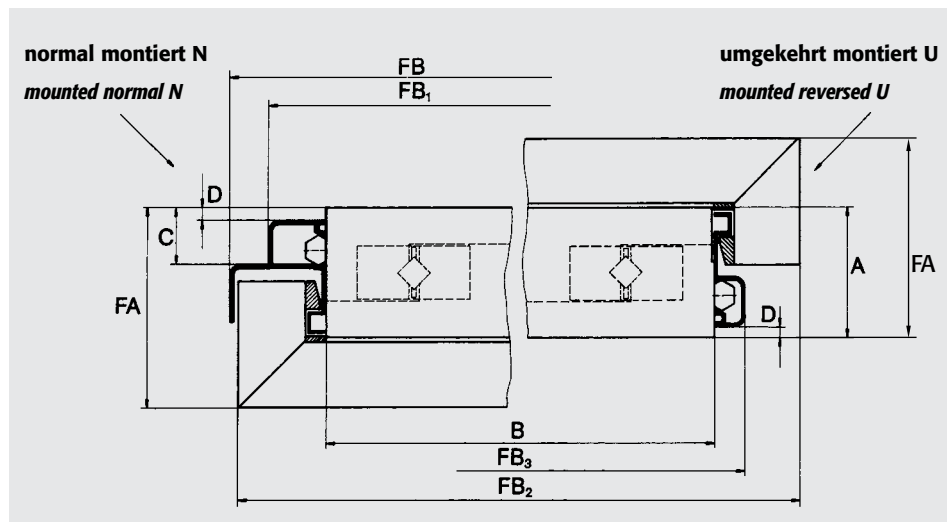

Sämtliche Schwalbenschwanz- und Rollen-Schlitten sind mit T-Nuten lieferbar.  
Ausgenommen Breite 40, Miniatur-Rollen-Schlitten und quadratische Normschlitten.

*All dovetail and roller slides can, to the exception of width 40 and of the miniature and square roller slide types, be delivered with T-slots.*

### 8.4 T-Nuten

#### T-slots

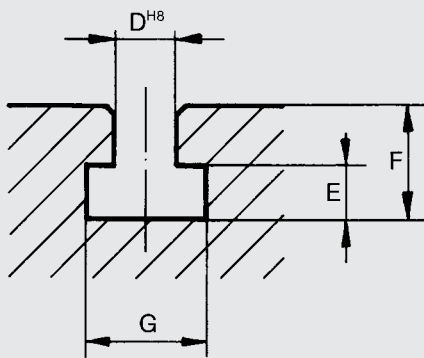

Gr.  
050  
060  
075

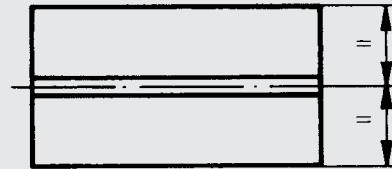

Gr.  
100  
150  
200

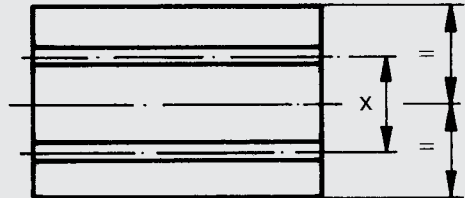

Gr.  
300  
400

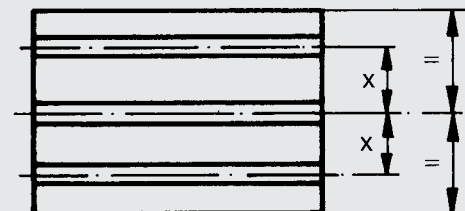

Größe Size	X	Stück-TN T-slots, pcs.	D	E	F	G
050	–	1	6	6	11	12,5
060	–	1	6	6	11	12,5
075	–	1	6	6	11	12,5
100	60	2	6	6	11	12,5
150	90	2	8	8	15	16,0
200	120	2	8	8	15	16,0
300	2 x 100	3	10	8	19	18,0
400	2 x 150	3	14	11	24	25,0



## 8.5 Positionsanzeige PA

### Position readout PA

Alle Schwalbenschwanz-Schlitten (Typ SS), Rollen-Schlitten (Typ RS) sind ab einer Baugröße von 75 mm mit einer digitalen Positionsanzeige ausgerüstet lieferbar. Verschiedene Einbauvarianten lassen ein Ablesen aus verschiedenen Blickrichtungen zu. Das Gehäuse besteht aus schlagfestem Kunststoff. Die digitale Anzeige ermöglicht über den gesamten Meßweg eine schnelle Einstellung.

*From size 75 mm on, all dovetail slides (type SS) and roller slides (RS) are equipped with a digital position readout. Different installation options allow to read the display from different viewing directions. The housing consists of shockproof plastic. The digital display allows to make fast adjustments over the complete measuring path.*

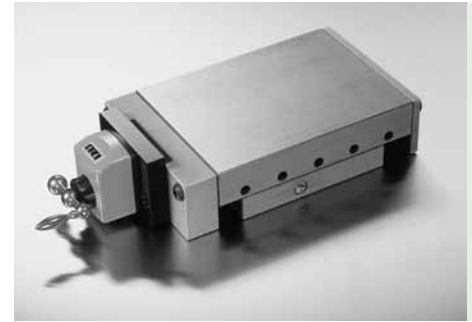
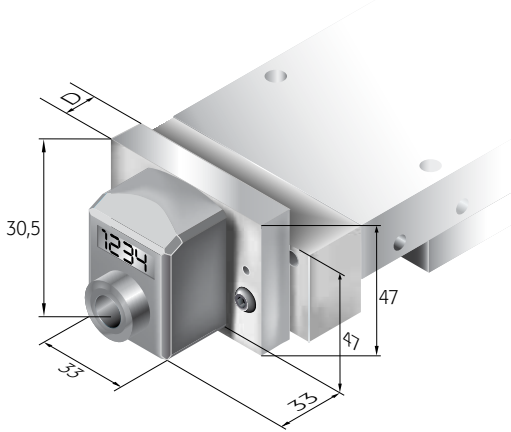

PA

#### Technische Daten

Zählwerk	4 Dekaden = max. 9999
Ziffernhöhe	ca. 3,5 mm
Hohlwelle	Ø 14 H7 (standard)
Gehäuse	Polyamid 6, schlagfest
Max. Umgebungstemp.	+80°C
Gehäusefarbe	orange
Gewicht	0,05 kg

#### Technical characteristics

Jumping figure counter	4 decades = max. 9999
Height of displayed figures	approx. 3.5 mm
Hollow shaft	Ø 14 H7 (standard)
Housing	of polyamide 6, shock resistant
Max. admissible ambient temperature	+ 80°C
Housing colour	orange
Weight	0.05 kg

#### Typenübersicht | List of types

Spindelsteigung <i>Spindle lead</i>	Anzeige nach einer Umdrehung <i>Readout after one turn</i>
1 mm	001,0
2 mm	002,0
4 mm	004,0
5 mm	005,0

Größe <i>Size</i>	Dicke Zwischenplatte <i>Thickness of distance plate D</i>
50	6
60	6
75	15
100	15
150	15
200	15
300	15
400	15

#### Bestellschlüssel

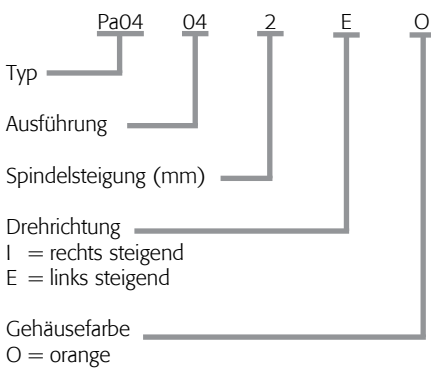

#### Order code

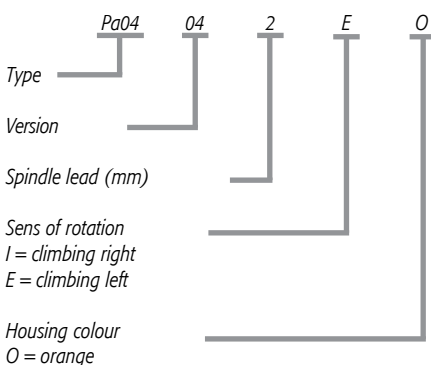

#### Ausführungen der Positionsanzeige PA Versions of the position readout PA

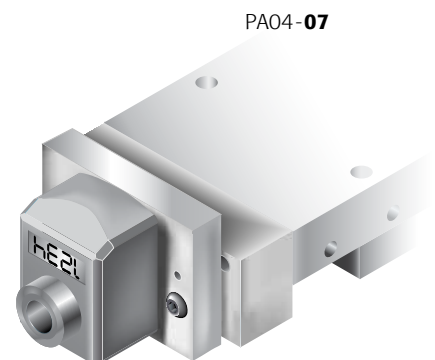
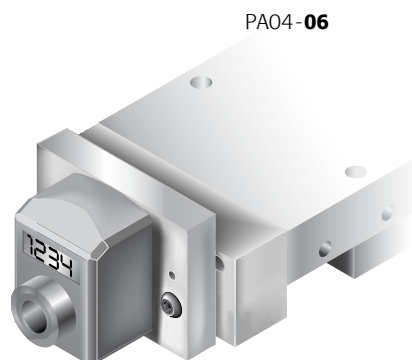
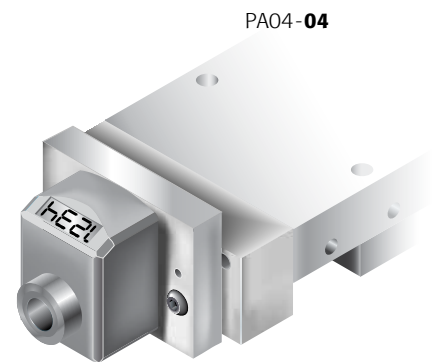
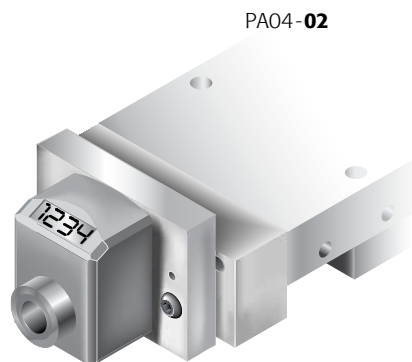



## 9.1 Montage-Winkel

### Mounting flanges

aus GG 25 sowie in Aluminium schwarz anodisiert, passend zu allen Standard-Schlitten. Montageflächen geschliffen, Innenseiten lackiert bzw. schwarz eloxiert. Standardbohrbilder bei Montagewinkel nicht möglich.

*The mounting flanges are of grey cast iron (GG 25) as well as of black anodized aluminium and suit for all standard slide types. The mounting surfaces are ground, the insides lacquered or anodized black. With mounting flanges, there are no standard drilling plans available.*

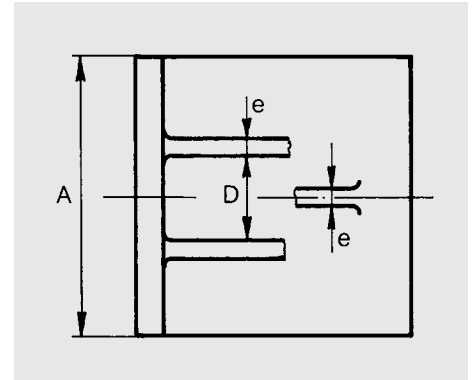

Größe Size	Bestellschlüssel Order code	A	B	C	D	e
030	MW 030 x 030 x 030	30	30	8	—	—
040	MW 040 x 040 x 040	40	40	10	—	—
050	MW 050 x 050 x 050	50	50	10	—	10
060	MW 060 x 060 x 060	60	60	10	—	8
075	MW 075 x 075 x 075	75	75	10	—	8
100	MW 100 x 100 x 100	100	100	15	—	10
100	MW 100 x 100 x 250	100	250	15	—	10
125 [Al]	MW 125 x 125 x 125	125	125	15	—	15
150	MW 150 x 150 x 150	150	150	18	55	10
150	MW 150 x 150 x 250	150	250	18	55	10
200	MW 200 x 200 x 200	200	200	20	135	10
200	MW 200 x 200 x 300	200	300	20	137	10
300	MW 300 x 300 x 300	300	300	25	220	12
300	MW 300 x 300 x 500	300	500	25	220	12
400	MW 400 x 400 x 400	400	400	30	230	15
400	MW 400 x 400 x 600	400	600	30	230	15

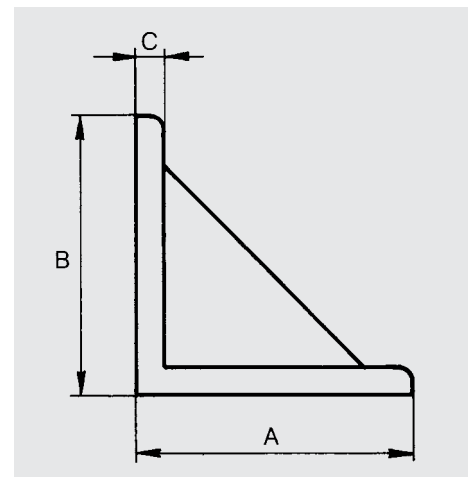

## 9.2 Drehteller für Schwalbenschwanz- und Rollen-Schlitten

### Turntables for dovetail and roller slides

Schlittenführungen von verschiedenen Größen und Ausführungen können mit Hilfe eines Drehtellers zu verdrehbaren Kreuztischen ausgerüstet werden. Die Drehteller sind um 360° schwenkbar. Die Skalenteilung ist 1° ablesbar in 2 Ausführungen.

Ausführung 1: mit Zahlen von 0 - 350

Ausführung 2: mit Zahlen links und rechts 0 - 180

*Different sizes and executions of slide guides, depending on the requirements, can be assembled with turntables in such a manner that a rotatable cross table is created. The turntables can rotate by 360°. They are equipped with a 1° read-out scale graduation and are delivered in two different types.*

*Type 1: with numbers from 0 to 350*

*Type 2: with numbers from 0 to 180, left and right*

Größe Size	A
075	18
100	18
150	20
200	20

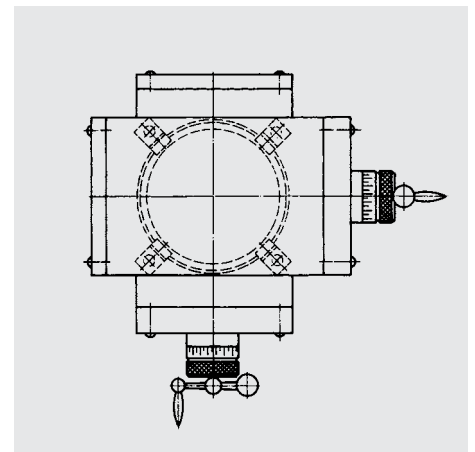
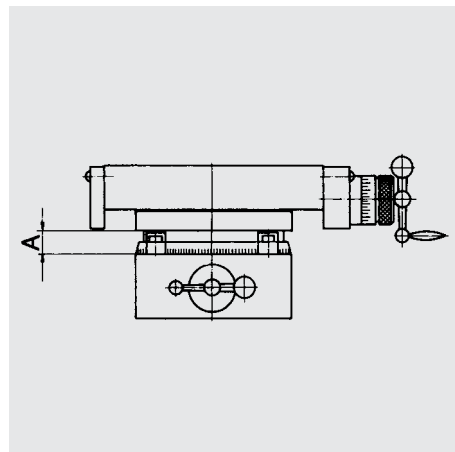

### 10.1 Standard-Bohrbilder

#### *Standard drilling plans*

Sämtliche Schlittenausführungen werden auf Wunsch mit Standard-Bohrbild geliefert. Die Häufigkeit der Bohrungsabstände variiert entsprechend der Tabellenwerte Ba/Bi der vorangehenden Seiten.

*If desired, all slide types are furnished with standard drilling patterns. The number of drill hole distances varied by tabular values Ba/Bi on preceding pages.*

Größe Size	a	b	b1	M	Gewinde-Tiefen Depth of thread R
<b>040</b>	15 (*25)	30	30	M3	6
<b>050</b>	28	28	20	M4	6
<b>060</b>	34	34	26	M4	6
<b>075</b>	62	62	34	M5	8
<b>100</b>	86	86	50	M6	10
<b>150</b>	130	130	76	M8	12
<b>200</b>	170	170	118	M8	16
<b>300</b>	260	260	190	M10	18
<b>400</b>	340	340	–	M12	25

Achtung: b1 gilt nur bei Typ RA im Außenteil für RA-Innenteil b verwenden – Toleranzen ± 0,15 mm.

*Caution: b 1 is operative for type RA only, exterior part. Use b for the interior part of type RA – Tolerances ± 0.15 mm.*

\* Gilt nur bei gekennzeichneten Typen im Katalog  
\* *Only valid for marked types in the catalogue*

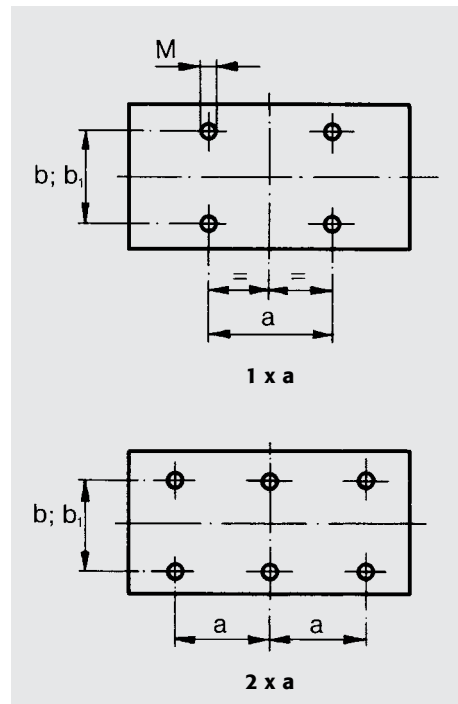

### 10.2 Bohrbilder MOAN/MEAN

#### *Drilling plans MOAN/MEAN*

Bohrbilder für Miniatur-Rollen-Schlitten MOAN/MEAN siehe Seite 22

*Drilling plans for miniature roller slides MOAN/MEAN see page 22*



#### **MOAN**

offene Ausführung

*open type*



#### **MEAN**

mit Endplatten

*with end plates*

## 10.3 Bohrbilder Endplatten

## Drilling plans for end plates

## 10.3.1 Bohrbilder ohne Spindel

## Drilling plans without spindle

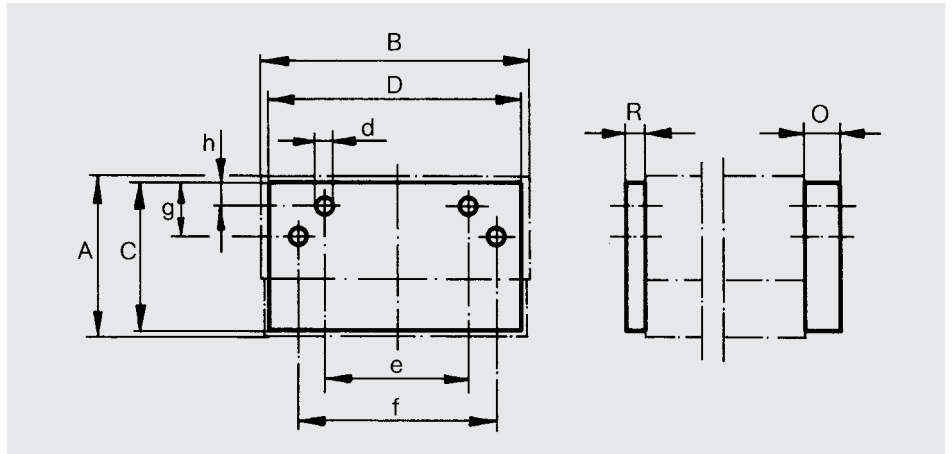

Größe Size	SE	RA	RE	KE	A	B	C	C*	D	R	O	e	h	f	g	Ø d
040	–	x	x	–	20	40	19	12,5	39,4	3	12	30	3,5	–	–	3,5
050	x	x	x	–	25	50	24	16,5	49,4	6	14	39	3,7	–	–	4,5
060	–	x	x	–	25	60	24	16,5	59,4	6	14	48	3,7	–	–	4,5
075	x	x	x	x	32	75	31	20,5	74,2	6	15	60	5,0	–	–	5,6
100	x	x	x	x	40	100	39	27,0	99,0	6	15	88	7,5	–	–	7,0
150	x	x	x	x	50	150	49	35,0	149,0	8	16	50	7,5	136	22,5	7,0
200	x	x	x	x	60	200	59	39,5	199,0	8	16	50	7,5	180	29,5	9,2
300	x	x	x	x	75	300	74	53,5	299,0	10	20	180	11,5	270	37,5	11,0
400	x	–	–	–	100	400	98	–	398,0	10	20	240	19,0	360	52,0	11,0

\* bei Schlitten Baureihe RA  
\* with slides of the RA line

## 10.3.2 Bohrbilder mit Spindel

## Drilling plans with spindle

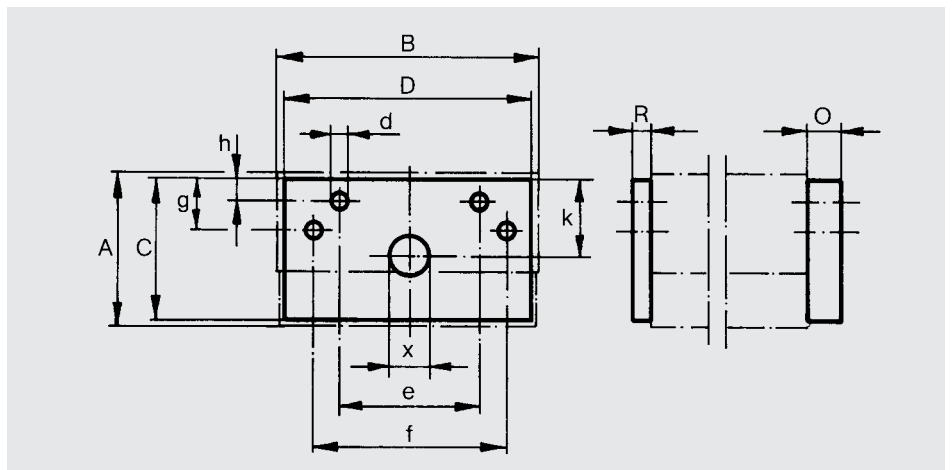

Bei Endplatten R ohne Maße K + X

With end plates type R, without sizes K + X

Größe Size	SS	SK	SM	RS	RK	RM	A	B	C	D	R	O	e	h	f	g	Ø d	k	X
040	–	–	–	x	–	x	20	40	19	39,4	3	12	30	3,5	–	–	3,5	10,5	10
050	x	x	x	x	x	x	25	50	24	49,4	6	19	39	3,7	–	–	4,5	12,2	18
060	–	–	–	x	x	x	25	60	24	59,4	6	19	48	3,7	–	–	4,5	12,2	18
075	x	x	x	x	x	x	32	75	31	74,2	6	21	60	5,0	–	–	5,6	16,5	22
100	x	x	x	x	x	x	40	100	39	99,0	6	21	88	7,5	–	–	7,0	20,5	22
150	x	x	x	x	x	x	50	150	49	149,0	8	28	50	7,5	136	22,5	7,0	25,5	38
200	x	x	x	x	x	x	60	200	59	199,0	8	28	50	7,5	180	29,5	9,0	34,5	38
300	x	x	x	x	x	x	75	300	74	299,0	10	20	180	11,5	270	37,5	11,0	40,0	48
400	x	x	x	–	–	–	100	400	98	398,0	10	20	240	19,0	360	52,0	11,0	63,0	48

**Bestellschlüssel**

**Order code**

**Bestellbeispiele**  
**Order examples**

**M E A N 0 6 0 0 1 8 0 0 0 5 0 B B A A**  
**S O G N 0 7 5 0 1 8 0 0 0 7 0 B A A A**

		1	2	3	4	5	6	7	8	9	10	11	12	13	14	15	16	17	18	19
<b>Typ</b>																				
<b>S</b>	Schwalbenschwanz-Schlitten																			
<b>R</b>	Rollen-Schlitten																			
<b>M</b>	Miniatur-Rollen-Schlitten																			
<b>Type</b>																				
<b>Bauart</b>																				
<b>O</b>	offene Ausführung																			
<b>E</b>	mit Endplatten																			
<b>S</b>	mit Spindel																			
<b>K</b>	mit Spindel und Kreuzkurbel																			
<b>H</b>	mit Handrad (Standard ab Größe 300)																			
<b>M</b>	mit Spindel und Mikrometerrandel																			
<b>A</b>	abgedichtete Ausführung																			
<b>P</b>	Positionsanzeige																			
<b>Y</b>	Kundenwunsch																			
<b>Materials</b>																				
<b>G</b>	Grauguss (Standard)																			
<b>A</b>	Aluminium (Standard)																			
<b>M</b>	Messing																			
<b>S</b>	Stahl																			
<b>V</b>	nichtrostender Stahl																			
<b>B</b>	Grauguss mit Gleitbelag-Beschichtung																			
<b>T</b>	Grauguss mit Turcite-Beschichtung																			
<b>Y</b>	Kundenwunsch																			
<b>Executions</b>																				
<b>N</b>	Standardbauhöhe																			
<b>H</b>	erhöhte Bauhöhe																			
<b>T</b>	mit T-Nuten																			
<b>Q</b>	quadratisch																			
<b>Y</b>	Kundenwunsch																			
<b>Size of slide B</b>																				
<b>000 - 999 mm</b>	(Standardwerte gem. Maßstabellen)																			
<b>Length of slide L</b>																				
<b>0000 - 9999 mm</b>	(Standardwerte gem. Maßstabellen)																			
<b>Stroke of slide C</b>																				
<b>0000 - 9999 mm</b>	(Standardwerte gem. Maßstabellen)																			
<b>Drilling plan</b>																				
<b>A</b>	ohne Bohrbild																			
<b>B</b>	mit Standard-Bohrbild im Innen- und Außenteil																			
<b>Y</b>	Kundenwunsch																			
<b>Surface</b>																				
<b>A</b>	keine Oberflächenbehandlung																			
<b>B</b>	schwarz anodisiert = Standard (nur bei Aluminium)																			
<b>C</b>	natur anodisiert (nur bei Aluminium)																			
<b>D</b>	chemisch vernickelt 0,005 mm																			
<b>E</b>	chemisch vernickelt 0,020 mm																			
<b>F</b>	brüniert																			
<b>G</b>	phosphatiert																			
<b>P</b>	plasmanitriert																			
<b>H</b>	hartcoadiert 0,030 mm																			
<b>Y</b>	Kundenwunsch																			
<b>Locking</b>																				
<b>A</b>	ohne Arretierung = Standard																			
<b>B</b>	Arretierung rechts																			
<b>C</b>	Arretierung links																			
<b>Y</b>	Kundenwunsch																			
<b>Cover</b>																				
<b>A</b>	keine Abdeckung = Standard																			
<b>B</b>	Faltenbalg normal montiert																			
<b>C</b>	Faltenbalg umgekehrt montiert																			
<b>D</b>	Faltenbalg mit Stahllamellen																			
<b>E</b>	Führungsbahnabstreifer																			
<b>L</b>	Luftspalt																			
<b>F</b>	Filzabstreifer																			
<b>N</b>	Nylonabstreifer																			
<b>Y</b>	Kundenwunsch																			

**1. Allgemein:** Durch die Erteilung der Aufträge erkennt der Besteller unsere folgenden Verkaufsbedingungen an. Andere Bedingungen, auch Geschäftsbedingungen des Bestellers, sind unzulässig, soweit sie unseren Bedingungen entgegenstehen, es sei denn, wir stimmen diesen anderen Geschäftsbedingungen ausdrücklich und schriftlich zu. Etwaigen Bedingungen des Bestellers wird hiernächst widersprochen. Der Lieferant behält sich an Mustern, Kostenvorschlägen, Zeichnungen u.ä. Informationen körperlicher und unkörperlicher Art – auch in elektronischer Form – Eigentums- und Urheberrechte vor, sie dürfen Dritten nicht zugänglich gemacht werden.

**2. Angebote:** Sämtliche Angebote sind freibleibend und unverbindlich. Für Zeichnungen und andere Angebotsunterlagen behalten wir uns das Eigentums- und Urheberrecht vor.

**3. Auftragserteilung:** Ein Auftrag gilt als erteilt, wenn er von uns schriftlich bestätigt ist. Sämtliche Ergänzungen, Abänderungen, telefonische oder mündliche Nebenabreden bedürfen zu ihrer Wirksamkeit unserer schriftlichen Bestätigung. Maße, Gewichte und Beschreibungen sind nach bestem Ermessen, aber ohne Verbindlichkeit anzugeben.

**4. Preise:** Unsere Preise verstehen sich ab Werk netto zuzüglich gesetzlicher Mehrwertsteuer, ausschließlich Verpackung, Versandkosten und Versicherung. Für Warenlieferungen mit einem Nettorechnungswert unter EUR 150,- berechnen wir einen Rechnungszuschlag von EUR 15,-.

**5. Zahlungsbedingungen:** Zahlungen sind zu leisten innerhalb 10 Tagen mit 2 % Skonto oder 30 Tagen rein netto. Lohnarbeiten und Reparaturen sind sofort rein netto zahlbar. Bei Aufträgen mit einem Wert größer als EUR 15.000,- oder einer Herstellungszeit von länger als 3 Monaten wird eine Anzahlung in Höhe von 1/3 der Auftragssumme mit Erhalt der Auftragsbestätigung und Anzahlungsrechnung sofort zur Zahlung fällig. Bei Zahlungsverzug werden unter Vorbehalt der Geltendmachung eines weiteren Schadens bankmäßige Zinsen und Provisionen berechnet. Die Zurückhaltung von Zahlungen oder die Aufrechnung wegen etwaiger vom Lieferant bestreitener Gegenansprüche des Bestellers sind nicht statthaft. Verschlechterung der Zahlungsfähigkeit des Bestellers oder die Nichteinhaltung der vereinbarten Zahlungsbedingungen berechtigen uns, Sicherheitsleistung für alle Forderungen aus dem Liefervertrag ohne Rücksicht auf Fälligkeit zu verlangen.

**6. Lieferzeit:** Die Lieferzeit beginnt, sobald sämtliche Einzelheiten der Ausführung festgestellt und beide Teile über alle Bedingungen des Geschäfts eingesehen sind. Die Lieferzeit ist eingehalten, wenn bis zu ihrem Ablauf der Liefergegenstand das Werk verlassen hat oder die Versandbereitschaft mitgeteilt ist. Ihre Einhaltung setzt die Erfüllung der Vertragspflichten des Bestellers voraus. Geraten wir mit unseren Lieferungen oder Leistungen in Verzug und gewährt uns der Besteller eine angemessene Nachfrist mit der ausdrücklichen Erklärung, dass er nach Ablauf dieser Frist die Annahme der Leistung ablehne und wird die Nachfrist nicht eingehalten, so ist der Besteller zum Rücktritt berechtigt. Mögliche Absprachen in Sachen Vertragsstrafen sind einzelvertraglich festzulegen. Unvorhergesehene Ereignisse, die außerhalb unseres Einflusses liegen, z.B. Betriebsstörungen, Streik, Aussperrung – im eigenen Werk oder beim Unterlieferanten – verlängern die Lieferzeit angemessen, und zwar auch dann, wenn sie während eines Lieferverzuges eintreten. Teillieferungen sind zulässig.

**7. Gefahretragung:** Mit der Meldung der Versandbereitschaft bzw. bergabe der Ware an den Transportunternehmer, spätestens jedoch mit dem Verlassen des Werkes geht die Gefahr, auch wenn frachtfreie Lieferung vereinbart ist, auf den Besteller über. Wenn nicht anders vereinbart, versichern wir die Ware im Namen des Bestellers und auf dessen Kosten gegen Verlust und Transportschäden.

**8. Verpackung:** Die Verpackung wird zu Selbstkosten berechnet und nicht zurückgenommen.

**9. Eigentumsvorbehalt:** Wir behalten uns das Eigentum an dem Liefergegenstand bis zum Eingang aller Zahlungen aus dem Liefervertrag vor. Bei vertragswidrigem Verhalten des Bestellers, insbesondere bei Zahlungsverzug, sind wir zur Rücknahme des Liefergegenstandes nach Mahnung berechtigt und der Besteller zur Herausgabe verpflichtet. In der Zurücknahme sowie in der Pfändung des Gegenstandes durch uns liegt ein Rücktritt vom Vertrag nur dann vor, wenn wir dies ausdrücklich schriftlich erklären. Der Besteller darf den Liefergegenstand weder verpfänden noch zur Sicherung übergreifen. Bei Pfändungen oder sonstigen Eingriffen Dritter hat der Besteller uns unverzüglich schriftlich zu benachrichtigen. Der Antrag auf Eröffnung des Insolvenzverfahrens berechtigt den Lieferant vom Vertrag zurückzutreten und die sofortige Rückgabe des Liefergegenstandes zu verlangen. Der Besteller ist berechtigt, den Liefergegenstand im ordentlichen Geschäftsgang weiterzuverkaufen. Er tritt uns jedoch bereits jetzt alle Forderungen ab, die ihm aus der Weiterveräußerung gegen den Abnehmer oder gegen Dritte erwachsen und zwar gleichgültig, ob die Vorbehaltsware ohne oder nach Verarbeitung weiterverkauft wird. Zur Einziehung dieser Forderung ist der Besteller auch nach der Abtretung ermächtigt. Unsere Befugnis, die Forderung selbst einzuziehen, bleibt hiervon unberührt; jedoch verpflichten wir uns, die Forderungen nicht einzuziehen, solange der Besteller seinen Zahlungsverpflichtungen ordnungsgemäß nachkommt. Wir können verlangen, dass der Besteller uns die abgetretenen Forderungen und deren Schuldner bekannt gibt, alle zum Einzug erforderlichen Angaben macht, die dazugehörigen Unterlagen aushändigt und den Schuldner die Abtretung mitteilt. Wird der Liefergegenstand zusammen mit anderen Waren, die uns nicht gehören, weiterverkauft, so gilt die Forderung des Bestellers gegen den Abnehmer in Höhe des zwischen uns und dem Besteller vereinbarten Lieferpreises als abgetreten. Die Verarbeitung oder Umbildung von Vorbehaltswaren wird durch den Besteller stets für uns vorgenommen. Wird die Vorbehaltsware mit anderen uns nicht gehörenden Gegenständen verarbeitet, so erwerben wir das Miteigentum an der neuen Sache im Verhältnis des Wertes der Vorbehaltsware zu den anderen verarbeiteten Gegenständen zur Zeit der Verarbeitung. Für die durch Verarbeitung entstehende Sache gilt im übrigen das gleiche wie für die Vorbehaltsware. Der Besteller ist verpflichtet, den Liefergegenstand während des Bestehens des Eigentumsvorbehalts gegen Diebstahl, Brand-, Feuer-, Wasser- und sonstige Schäden zu versichern und uns hiervon Anzeige zu machen. Erfolgt dies nicht, so sind wir berechtigt, auf Kosten des Bestellers die Versicherungen abzuschließen. Der Eigentumsvorbehalt und die uns zustehenden Sicherungen gelten bis zur vollständigen Freistellung aus Eventualverbindlichkeiten, die wir im Interesse des Bestellers eingegangen sind. Wir verpflichten uns, die uns zustehenden Sicherungen insoweit freizugeben, als ihr Wert die zu sichernden Forderungen, soweit diese noch nicht beglichen sind, um mehr als 20 % übersteigt.

**10. Vorkaufrecht:** Bei Betriebsabgabe, Insolvenzverfahren und Liquidation des Bestellers haben wir an allen von uns gelieferten Waren das Vorkaufrecht.

**11. Mängelhaftung:** Für Mängel der Lieferung, zu denen auch das Fehlen ausdrücklich zugesicherter Eigenschaften gehört, haften wir unter Ausschluss weiterer Ansprüche in der Weise, dass wir alle diejenigen Teile unentgeltlich nach unserem billigen Ermessen unterliegenden Wahl ausbessern oder neu

liefern, die sich innerhalb von 12 Monaten seit Gefahrenübergang infolge eines vor dem Gefahrenübergang liegenden Umstandes, insbesondere wegen fehlerhafter Bauart, schlechter Baustoffe oder mangelnder Ausführung als unbrauchbar oder in ihrer Brauchbarkeit nicht unerheblich beeinträchtigt herausstellen. Die Feststellung solcher Mängel ist uns unverzüglich schriftlich mitzuteilen. Ersetzte Teile gehen in unser Eigentum über; sie sind uns auf Verlangen frei Haus zurückzusenden. Für ungeeignete oder unsachgemäße Verwendung, fehlerhafte Montage bzw. Inbetriebsetzung durch den Besteller oder Dritte, natürliche Abnutzung, fehlerhafte oder nachlässige Behandlung, ungeeignete Betriebsmittel, Austauschwerkstoffe, mangelhafte Bauarbeiten, chemische, elektrochemische oder elektrische Einflüsse wird keine Gewähr übernommen, sofern sie nicht auf unser Verschulden zurückzuführen sind. Durch etwa seitens des Bestellers oder Dritte unsachgemäß ohne vorherige Genehmigung vorgenommene Änderungen oder Instandsetzungsarbeiten, wird die Haftung für die daraus entstehenden Folgen aufgehoben. Wenn wir eine uns gestellte angemessene Nachfrist für die Ausbesserung oder Ersatzlieferung bezüglich eines von uns zu vertretenden Mangels durch unser Verschulden fruchtlos verstreichen lassen, kann der Besteller vom Vertrag zurücktreten. Das Rücktrittsrecht des Bestellers besteht auch bei Unmöglichkeit oder bei Unvermögen der Ausbesserung oder Ersatzlieferung durch uns. Bei unberechtigten Mängelrügen, die umfangreiche Nachprüfungen verursachen, werden die Kosten der Prüfung dem Besteller in Rechnung gestellt. Weitere Ansprüche des Bestellers, insbesondere ein Anspruch auf Ersatz von Schäden, die nicht an dem Liefergegenstand selbst entstanden sind, sind ausgeschlossen. Dieser Haftungsausschluss gilt nicht bei Vorsatz, bei grober Fahrlässigkeit des Inhabers oder leitender Angestellter sowie bei schuldhafter Verletzung wesentlicher Vertragspflichten. Bei schuldhafter Verletzung wesentlicher Vertragspflichten haftet der Lieferant – außer in den Fällen des Vorsatzes und der groben Fahrlässigkeit des Inhabers oder leitender Angestellter – nur für den vertragstypischen, vernünftigerweise vorhersehbaren Schaden. Der Haftungsausschluss gilt ferner nicht in den Fällen, in denen nach Produkthaftungsgesetz bei Fehlen des Liefergegenstandes für Personen- oder Sachschäden an privat genutzten Gegenständen gehaftet wird. Er gilt auch nicht bei Fehlen von Eigenschaften, die ausdrücklich zugesichert sind, wenn die Zusicherung gerade bezweckt hat, den Besteller gegen Schäden, die nicht am Liefergegenstand selbst entstanden sind, abzusichern.

**12. Verjährung:** Alle Ansprüche des Bestellers – aus welchen Rechtsgründen auch immer – verjähren in 12 Monaten, sofern gesetzlich nicht zwingend etwas anderes gilt.

**13. Erfüllungsort und Gerichtsstand:** Erfüllungsort für Lieferung und Zahlung ist Löffingen-Ünadingen. Gerichtsstand ist das für den Sitz des Lieferers zuständige Gericht. Wir sind auch berechtigt, am Sitz des Bestellers zu klagen.

**14. Anwendbares Recht:** Auf das Vertragsverhältnis findet das deutsche Recht Anwendung. Die Anwendung des internationalen Kaufrechts wird ausgeschlossen.

**1. General:** By placing an order with us, the customer recognises the Terms of Sale and Delivery as set forth hereafter. Any other terms and conditions, such as the customer's conditions are invalid in so far as they do conflict with present Terms of Sale and Delivery, unless we expressly consent to these trading conditions in written form. As a precaution, already at this stage we hereby object to any probably existing trading conditions the customer may have established. The supplier, irrespective of whether or not these are of tangible or intangible nature or exist in electronic form of what kind ever, retains title and reserves its copyright to samples, cost estimates, drawings and/or similar information and no such cost estimates, drawings and/or similar information must be disclosed to any third party whoever.

**2. Offers:** All offers are without obligation and subject to alteration. We reserve the right of ownership of drawings or other offer documents.

**3. Placing of orders:** An order is considered as placed if confirmed by us in writing. All supplements, amendments and subsidiary agreements, no matter whether made orally or on the phone, are valid only if confirmed by us in writing. All measurements, weights, pictures and descriptions must be indicated to the customer's best discretion, but without any obligation.

**4. Prices:** Our prices are ex works, net plus legal VAT rate excluding packing, freight and insurance. For deliveries with an amount smaller than EURO 150.00, we charge EURO 15.00 extra.

**5. Payment terms:** All payments must be effected within ten (10) days with 2 % discount or thirty (30) days net without deduction. Wage works and repairs are immediately payable days without deduction. With orders exceeding an overall contract amount of EURO 15,000.00 or orders that take a production time of more than three (3) months a payment on account in the amount of 1/3 of the order placed falls immediately due for payment upon receipt of order confirmation and payment on account invoice. In the event the customer is in default, the contractor is entitled – subject to the assertion of further compensation – to charge the customer with interest rates in the amount of such rates as usually charged by commercial banks for open overdrafts including usual commission. The customer is not allowed to withhold payments or to claim set-off by reason of cross-claims probably denied by the supplier. Any deterioration of customer's ability to pay or insolvency of the agreed payment terms will entitle us to demand provision of security for all supply contract claims, irrespective whether fallen due or not.

**6. Delivery term:** The delivery term starts running as soon as both parties have come to terms about all conditions of their deal. The delivery term limit is considered as observed if the object of delivery has left the supplier's works before date the delivery term expires or if the supplier has notified the customer of his readiness for shipment. Observance of the delivery time is subject to the proper fulfilment of the customer's contractual obligations. In the event we should fail to deliver or if we get into delay with our performances, the customer shall concede us a reasonable additional period of time along with his statement saying that he will refuse to accept said performances after expiry of this additional time. In case this grace period is not complied with the customer shall be entitled to terminate the agreement. All agreements probably made in regard to penalties have to be stipulated in an individual contract. Any unforeseen events that are not within our control, such as operational break-downs, strikes or lockouts, no matter whether occurring in our works or with any of our subcontractors, shall reasonably extend the delivery term, even if occurring at a time where the supplier is in delay with his delivery. Partial consignment is admissible.

**7. Risk taking:** If the customer has been notified of our readiness to ship the consignment or if the consignment is delivered to the forwarding agent the risk passes on to the customer, i.e. when leaving our works at its latest, even if carriage paid delivery was stipulated. Unless agreed otherwise, we shall – in the customer's name and at his expense – take out an insurance coverage against loss and transport damages.

**8. Packing:** Packing is billed at cost and will not be taken back.

**9. Reservation of ownership:** We reserve the right of ownership of the object delivered till all payments to be effected under the delivery contract have been received. In the event the customer acts contrary to the terms of the agreement, especially in case of failure to pay on due date, we shall – after giving notice to the debtor – be entitled to take the object of delivery back and the customer be obliged to return it. Unless the Hire-Purchase Act is applicable, the taking back of the object of delivery or the seizure of it implies the re-scission of the agreement from our side only if explicitly stated in writing. In case the customer's property or assets are subject to an order of attachment, the customer must notify us immediately thereof. The customer must neither pledge nor transfer the goods ordered by way of security. However, he already now assigns to us all claims that might accrue from it against his own client or third party whoever, regardless whether or not he resells said goods under reservation of ownership without or after any further modification or treatment. In the event a petition for insolvency proceedings has been filed, the supplier shall be entitled to withdraw from contract and to demand prompt restitution of the goods ordered. The customer is entitled to collect any such claims even after the above assignment. This, however, does not affect our qualification to collect the claim ourselves, but we oblige ourselves not to collect any such claims as long as the customer duly fulfils his obligations to pay. We may demand the customer to notify us of the assigned claims and of the corresponding debtors and to provide all necessary information for the collection of the receivables and to inform his debtors thereof. If the object of delivery is resold together with goods not owned by us the customer's claim against his own client is considered as assigned to us at a rate equivalent to the delivery price agreed between us and our customer. In case the customer treats or modifies the goods delivered under reservation of ownership, any such treatment or modification is made on our behalf. If the object delivered under reservation of ownership is combined or supplemented with other objects not in our ownership, we shall acquire fractional ownership, this is to say on a pro rata base in regard to all other new attached or new included objects at the time they have been processed, treated, assembled, fixed, joined or mounted otherwise. The same as set out hereinbefore in regard to the goods delivered under reservation of ownership shall apply for the new object thus created. During the time we own the goods delivered under reservation of ownership the customer is obliged to take out an insurance to assure the object of delivery against theft, fire and water hazard as well as against any other damages and must send us a notification thereof. In case the customer fails to do so, we ourselves shall be entitled to take out corresponding insurance on his behalf. The reservations of ownership including the securities we are entitled to shall be valid and operative until complete release from our contingent liability whatsoever that we have assumed in the customer's interest: We hereby oblige ourselves to release the securities we are entitled to in as far as their overall value exceeds the unsettled claims to be secured by more than 20%.

**10. Right of pre-emption:** In the event of a close down of the customer's operations or if bankruptcy proceedings have been instituted against his company or if his company is wound up, we shall – in regard to all goods delivered by our company – be entitled to exercise the right of pre-emption.

**11. Liability of defects:** To the exclusion of further claims we assume liability for deficiencies of the delivery including absence of explicitly warranted qualities in such manner as follows: we shall, at our reasonably exercised choice and discretion, either repair or replace all those parts free of charge that have proven unserviceable or the serviceableness of which turned out to be a significant impairment and shall do so within twelve (12) months as of the date of the passing of the risk if any such failure is owing to reasons occurred before said date, particularly if attributable to imperfect construction, to bad construction materials or a deficient make. If any such deficiencies are detected the customer must notify us immediately thereof. Replaced parts shall pass into our ownership and, if requested, must be returned to us free domicile. We deny any liabilities whatsoever attributable to any inappropriate or inexperienced use, imperfect mounting or commissioning by the customer or third parties whoever or to natural wear, incorrect or negligent treatment, use of inappropriate operation material, substitute materials, deficient construction works, chemical, electrochemical or electric influences, if these are not due to our own fault. We do not assume any liabilities and shall not be responsible for any consequences that might probably arise if the customer or any third party whoever undertakes to perform repair works or modifications without our explicit prior consent. If we fail to comply with an additional period of time a customer has granted us for the repair of a deficiency attributable to us or to provide replacement, the customer shall be entitled to cancel the agreement. The customer is also entitled to rescind the agreement in case the repair or the replacement is impossible or if we should be unable to perform it. With unjustified claims in respect to defects requiring to make comprehensive investigations and inspections the cost for any such investigations will be billed to the customer. Further claims raised by the customer, in particular compensation for damages not occurred at the object of delivery itself are excluded. This exclusion of liability shall not be operative in case the above damages are attributable to actions of the owner or its executives and have been motivated by intention or gross negligence or if there is an infringement of essential contractual obligations. In the event of a culpable infringement of essential contractual obligations, the supplier is – to the exclusion of actions motivated by intention or gross negligence – only liable for contract specific, reasonably foreseeable damages. In addition, the above exclusion of liability does not apply for any cases where liability is incurred pursuant to the Product Liability Act for deficiencies of the object of delivery or for personal injury and damage to private property. Also, it shall not apply if explicitly guaranteed qualities are missing and if it is the purpose of this guarantee to insure the customer against any damages not occurred at the object of delivery itself.

**12. Limitation of the right of action:** All claims the supplier may be entitled to, no matter on what legal grounds, shall, unless not otherwise provided by imperative provision of the law, become statute-barred after 12 month.

**13. Place of delivery and payment, place of jurisdiction:** Place of delivery and payment is Löffingen-Ünadingen. The court having venue shall be the competent court at the headquarters of the supplier's undertaking. We shall nevertheless be entitled to file an action before court with any competent court having venue at our own and thus the customer's head office.

**14. Applicable law:** Any contractual relationship under these Terms of Sale and Delivery is subject to the law of the Federal Republic of Germany. Application of United Nations Convention on Contracts for the International Sale of Good excluded.

Stand: 10. Januar 2006 | State: 10. January 2006





Föhrenbach GmbH



Föhrenbach AG

## Die Föhrenbach Firmengruppe

1975 durch Manfred Föhrenbach gegründet, zählt sie heute zu den führenden Herstellern in der Automatisierungstechnik und im Präzisionsmaschinenbau.

- Das umfangreiche Lieferprogramm bietet nahezu alle Komponenten für Ihre Automatisierungstechnik aus einer Hand.
- Die hohe Fertigungstiefe, ermöglicht durch die Werke in Löffingen-Unadingen (Deutschland), Weinfelden (Schweiz) und Sligo (Irland) sowie modernste Produktionsanlagen sichern eine konstant hohe Qualität.

Maßgeschneiderte Komplettlösungen für nahezu alle Branchen sind weltweit im Einsatz, zum Beispiel zum: Messen, Prüfen, Sortieren, Palettieren, Richten, Fräsen, Bohren, Schleifen, Schweißen, Kleben, Schrauben, Nieten, Laserpräzisionsschneiden, ...

## The Föhrenbach Group

Founded in 1975 by Manfred Föhrenbach, the Group today numbers among the leading producers in the automation systems and machine building branch.

- The wide-spread product line offers nearly all components you need to cover the full spectrum of your special automation technique tasks.
- The large manufacturing range, made possible by our plants located in Löffingen-Unadingen (Germany), Weinfelden (Switzerland) and Sligo (Ireland) and latest production facilities assure permanent high quality.

Customized complete solutions for almost all branches: Föhrenbach units are on duty world-wide, e.g. for measuring, checking, assorting, palletising, adjusting, milling, drilling, grinding, welding, gluing, screwing, riveting, laser precision cutting, ...

## ■ Unser Lieferprogramm

### Mechanische Komponenten/ Manuelle Führungen

- Schwalbenschwanzschlitten
- Kreuzrollenschlitten
- Miniatur-Rollenschlitten
- Kreuztische

### Motorische Präzisionsschlitten/Spindeltriebe

- Kugelbüchsenführungen KBS / KCS
- Profilverführungsschlitten PFS / PCS
- Kreuzrollen- und Schwalbenschwanzführungen MR, MS

### Motorische Präzisionsschlitten/ Integrierter Linearmotor

- Kugelbüchsenführung KCL
- Profilverführungsschlitten PFL / PCL
- Handlingsmodul LDH

### Rundtische / Rotationsachsen

- Rundtisch mit Schneckentrieb RT1, RT2A
- Rundtisch mit Direktantrieb RT3
- Schwenkeinheit für Rundtische
- Teilapparat TA3G

### Komplettssysteme / Mehrachssysteme

#### Pressachsen

#### Steuerungen

- Strecken- und Bahnsteuerungen
- Schaltschrank-Komplettssysteme

#### Antriebe

- Schrittmotore und AC-Servomotore
- Leistungsendstufen / Servoverstärker
- Motore mit integriertem Leistungsteil

#### Zubehör

## ■ Our range of products

### Mechanical components/ Manual guides

- Dovetail slides
- Roller bearing slides
- Miniature roller slides
- Cross tables

### Motorized precision slides / Spindle drive

- Ball bushing slides KBS / KCS
- Profiled guide slides PFS / PCS
- Roller bearing and dovetail guides MR, MS

### Motorized precision slides/ Integrated linear motor

- Ball bushing slide KCL
- Profiled guide slides PFL / PCL
- Handling module LDH

### Rotary tables / Rotary axis

- Rotary table with worm gear RT1, RT2A
- Rotary table with direct drive RT3
- Swivel unit for rotary tables
- Dividing apparatus TA3G

### Complete systems / Multi axis systems

#### Pressing axis

#### Control systems

- Straight line and continuous path control systems
- control cabinet-complete systems

#### Drives

- Stepper motors and AC servomotors
- Power amplifiers / Servo amplifiers
- Motors with integrated power

#### Accessories

### ■ Föhrenbach GmbH

Lindenstraße 34  
D-79843 Löffingen-Unadingen  
Telefon +49 (0) 7707 159 0  
Telefax +49 (0) 7707 159 70  
info@foehrenbach.com  
www.foehrenbach.com

### ■ Föhrenbach AG

Tannenwiesenstraße 3  
CH-8570 Weinfelden  
Telefon +41 (0) 71 626 26 76  
Telefax +41 (0) 71 626 26 77  
info.ch@foehrenbach.com  
www.foehrenbach.com



Föhrenbach®  
Positionier-Systeme